



**"IT FEELS SO GOOD TO SEE  
the things we have fought  
for for so many years  
FINALLY COMING TO PASS."**

*Odessa B. Cox*

**of Access, Excellence & Empowerment**

**COLLEGE CATALOG**

**2016-17**

# College Catalog

2016-2017



Follow us on:



[facebook.com/LASouthwestCollege](https://www.facebook.com/LASouthwestCollege)



[twitter.com/LASCCampus](https://twitter.com/LASCCampus)



[Instagram .com/LASCCougars](https://www.instagram.com/LASCCougars)

**Los Angeles Southwest College**

**1600 West Imperial Highway**

**Los Angeles, California, 90047**

**[www.lasc.edu](http://www.lasc.edu)**

**323-241-5225**

[Los Angeles Southwest College](http://www.lasc.edu) is fully accredited by the [Accrediting Commission for Community and Junior Colleges \(ACCJC\)](http://www.wasc.org)/[Western Association of Schools and Colleges \(WASC\)](http://www.wasc.org)



# Table of Contents

<b>WELCOME TO LASC</b>		<b>STUDENT RESOURCES</b> .....	<b>92</b>
◆ PRESIDENT’S MESSAGE .....	4	◆ STUDENT SUCCESS CENTER .....	93
◆ BOARD OF TRUSTEES .....	5	◆ VETERANS SERVICES .....	93
◆ DISTRICT ADMINISTRATION .....	5	◆ CAMPUS SAFETY & PARKING .....	94
◆ LASC ADMINISTRATION .....	5	<b>COMMUNITY RESOURCES</b> .....	<b>96</b>
<b>GENERAL INFORMATION</b>		◆ COMMUNITY SERVICES .....	97
◆ ACCREDITATION .....	6	◆ BRIDGES TO SUCCESS .....	98
◆ HISTORY .....	7	◆ CAREER & TECHNICAL EDUCATION .....	99
◆ INSTRUCTIONAL PROGRAMS .....	9	<b>ADMINISTRATIVE SERVICES</b> .....	<b>101</b>
◆ EDUCATIONAL PHILOSOPHY .....	10	<b>ACADEMIC AFFAIRS</b> .....	<b>105</b>
◆ MISSION STATEMENT AND GOALS .....	11	◆ LASC DEANS .....	106
◆ STUDENT LEARNING OUTCOMES .....	12	◆ ELEARNING AND DISTANCE LEARNING.....	107
◆ INSTITUTIONAL LEARNING OUTCOMES .....	13	<b>ACADEMIC REQUIREMENTS</b>	
◆ LASC FOUNDATION.....	14	◆ GRADUATIONS REQUIREMENTS .....	111
<b>ACADEMIC CALENDAR 2016-2017</b> .....	<b>16</b>	◆ UNIVERSITY TRANSFER INFORMATION.....	112
<b>ADMISSIONS AND REGISTRATION</b> .....	<b>17</b>	◆ GE REQUIREMENTS .....	114
◆ FEES .....	20	◆ CSU-GE REQUIREMENTS .....	116
◆ RESIDENCY .....	21	◆ IGETC REQUIREMENTS .....	118
◆ NON-RESIDENT FEES & TUITION .....	22	◆ OTHER PROGRAM REQUIREMENTS .....	120
◆ INTERNATIONAL STUDENTS .....	25	<b>ACADEMIC DEPARTMENTS &amp; PROGRAMS</b>	
◆ TRANSCRIPTS .....	26	◆ ARTS & HUMANITIES .....	122
◆ STUDENT SUCCESS AND SUPPORT		◆ BEHAVIORAL & SOCIAL SCIENCES.....	127
PROGRAMS .....	28	◆ BUSINESS .....	137
<b>ACADEMIC INFORMATION AND REGISTRATION</b>		◆ CHILD DEVELOPMENT.....	149
◆ CONDITIONS OF ENROLLMENT .....	30	◇CHILD DEVELOPMENT CENTER .....	150
◆ LIMITATION ON ENROLLMENT .....	32	◆ ENGLISH & FOREIGN LANGUAGE.....	154
◆ CREDIT BY EXAMINATION .....	36	◇COMPETITION & PUBLICATION .....	155
◆ PREREQUISITES .....	45	◆ MATHEMATICS .....	162
◆ GRADING SYSTEM.....	46	◆ NATURAL SCIENCES, HEALTH & KINESIOLOGY	166
◆ ACADEMIC STANDARDS .....	51	◆ NURSING .....	170
◆ ACADEMIC HONORS .....	52	<b>FACULTY &amp; ADMINISTRATION</b> .....	<b>177</b>
◆ ACADEMIC PROBATION & DISMISSAL .....	54	<b>CLASSIFIED STAFF</b> .....	<b>180</b>
◆ PROBATION AND LOSS OF BOG FEE WAIVER		<b>FACULTY EMERITI</b> .....	<b>182</b>
ELIGIBILITY .....	55	<b>COURSE DESCRIPTIONS</b> .....	<b>184</b>
<b>OFFICE OF THE PRESIDENT</b> .....	<b>58</b>	<b>CONSUMER INFORMATION/DISTRICT POLICIES</b> ..	<b>231</b>
<b>STUDENT SERVICES</b> .....	<b>59</b>	<b>GLOSSARY</b> .....	<b>242</b>
◆ FINANCIAL AID.....	60	<b>INDEX</b> .....	<b>246</b>
◆ ASO.....	76		
◆ CLUB AND ORGANIZATIONS .....	78		
◆ COUNSELING .....	84		
◆ LIBRARY.....	91		

# Welcome to Los Angeles Southwest College!

As the newly appointed Interim President, I can assure you that for nearly 50 years, LASC has supported the South Los Angeles community by providing educational opportunities for all who sought to enhance their circumstances. I encourage you to commit to identifying and completing your goals at LASC. We offer an array of programs and services in beautifully designed facilities all created with your success in mind. Use your time wisely at LASC, as we are well prepared to assist you whether your goal is to transfer to a four-year college or university or to enter a job market whereby 2020, 65% of the jobs openings will require some postsecondary education.

You have my assurance that your education is in good hands with faculty and staff members as well as administrators who are committed to your success and making the time you spend at LASC as rewarding as possible. As our mission statement says, we are committed to empowering you to achieve your academic and career goals at this college and beyond. I encourage you to take every opportunity to engage in the classroom, within programs and organizations as well as in our wonderful larger community. It is my hope that when we cross paths, I will hear from you that your experience at LASC is exceeding your wildest dreams of what higher education has to offer.

All the best,

Denise F. Noldon, Ph.D.

Interim President



Dr. Denise Noldon  
Interim President



### LOS ANGELES COMMUNITY COLLEGE DISTRICT

770 Wilshire Boulevard  
Los Angeles, CA, 90017  
213-891-2000

### LOS ANGELES SOUTHWEST COLLEGE

1600 West Imperial Highway  
Los Angeles, CA, 90047  
323-241-5400

### LOS ANGELES UNIFIED SCHOOL DISTRICT

333 South Beaudry Avenue  
Los Angeles, CA ,90017  
213-241-1000

#### BOARD OF TRUSTEES

Scott J. Svonkin  
President

Sydney K. Kamlager  
First Vice President

Mike Fong  
Second Vice President

Mike Eng

Andra Hoffman

Ernest H. Moreno

Nancy Pearlman

Alexa Victoriano  
Student Trustee

#### DISTRICT ADMINISTRATION

Dr. Francisco C. Rodriguez  
Chancellor

Dr. Adriana Barrera  
Deputy Chancellor

Dr. Robert B. Miller  
Vice Chancellor, Finance and Resource  
Development

Dr. Ryan M. Cornner  
Vice Chancellor, Educational Programs  
and Institutional Effectiveness

Dr. Albert J. Roman  
Vice Chancellor, Human Resources

Dr. Kevin Jeter  
Interim General Counsel

James D. O'Reilly  
Chief Facilities Executive

#### COLLEGE ADMINISTRATION

Dr. Denise Noldon  
Interim President

Dr. Lawrence Bradford  
Vice President, Academic Affairs

Dr. Howard Irvin  
Vice President, Student Services

Daniel Hall  
Vice President,  
Administrative Services

Pamela Sanford  
Associate Vice President,  
Administrative Services

Dr. Tangelia Alfred  
Dean, Curriculum, Health,  
Kinesiology, Natural Sciences and  
Mathematics

Rick Hodge  
Dean, Career Technical Education

Dr. Allison P. Moore  
Dean, Library, Arts & Humanities,  
Behavioral & Social Sciences  
Distance Education and English &  
Foreign Languages

Jose Alfred Gallegos  
Dean, Institutional Advancement

Reginald Morris  
Dean, Student Services

#### MIDDLE COLLEGE HIGH

1600 West Imperial Highway  
Los Angeles, CA, 90047  
323-418-4700

Betty Washington  
Principal

### ACCURACY STATEMENT

The Los Angeles Community College District and Los Angeles Southwest College (LASC) have made every effort to make this catalog accurate and may, without notice, change general information, courses or programs offered. The reasons for change may include student enrollment, level of funding, or other issues decided by the District or College. The District and College also reserve the right to add, change, or cancel any rules, regulations, policies and procedures as provided by law.

## ACCREDITATION

Los Angeles Southwest College is fully accredited by the Accrediting Commission for Community and Junior Colleges (ACCJC)/Western Association of Schools and Colleges (WASC). Accreditation is a status granted to an educational institution that has been found to meet or exceed stated criteria of educational quality. Institutions voluntarily seek accreditation and it is conferred by non-governmental bodies.

Accreditation has two fundamental purposes:

- To assure the quality of the institution; and
- To assist in the improvement of the institution.

Accreditation of an institution by an institutional accrediting body certifies to the general public that the institution:

- Has appropriate purposes.
- Has the resources needed to accomplish its purposes.
- Can demonstrate that it is accomplishing its purposes.
- Gives reason to believe it will continue to accomplish its purposes.

Every six years, ACCJC institutions must undergo a comprehensive self-study to be submitted to ACCJC for reaffirmation of accreditation status.

Information about filing a complaint is available at <http://www.accjc.org/complaint-process>.

10 Commercial Boulevard, Suite 204 Novato, CA 94949	Telephone: (415) 506-0234 Fax: (415) 506-0238 Website: <a href="http://www.accjc.org/">http://www.accjc.org/</a> Email: <a href="mailto:accjc@accjc.org">accjc@accjc.org</a>
--	---

The Los Angeles Southwest College Nursing Program is accredited through the California Board of Registered Nurses. Information concerning the commission or the Los Angeles Southwest College's accreditation status can found by contacting:

Board of Registered Nursing P.O. Box 944210 Sacramento, CA 94244-2100	Telephone: (916) 322-3350 Fax: (916) 574-7697 Website: <a href="http://www.rn.ca.gov/index.shtml">http://www.rn.ca.gov/index.shtml</a> Email: <a href="mailto:BRN.Licensing@dca.ca.gov">BRN.Licensing@dca.ca.gov</a>
---	---



# Los Angeles Southwest College 1967-2017

As it stands on the verge of its 50th anniversary, Los Angeles Southwest College is the product of decades of hard work, vision and perseverance to achieve the dream of its principal founder, Odessa B. Cox.

The Cox family and a small group of community members started fighting in 1947 to bring a comprehensive community college to South Los Angeles. The path to today was not easy and was the result of the dedication of many.

Today, Los Angeles Southwest College, part of the Los Angeles Community College District, houses state-of-the-art facilities, including its recently renovated Library and Little Theater as well as the brand new School of Career and Technical Education building, where students receive top-notch instruction from a dedicated group of educators.

Cox and her husband, Raymond Cox, married in 1941 in Bessemer, Alabama, moved to Los Angeles in 1943, and in 1945 opened Utopia Cleaners in Watts, which remained in business for 48 years. They were staunch believers in education and continuously sought knowledge in formal and informal educational settings. The couple also worked on projects such as to increase the hiring of African-Americans and Mexican-Americans at banks and grocery stores in Watts.



Odessa B. Cox

Odessa Cox would eventually join the area's Parent Teachers

Association where she pushed for an improved educational experience for local students. Specifically, she worked diligently with others to change the image of African-Americans in state-adopted textbooks.

Cox and supporters also lobbied tirelessly for a college to be located in a neighborhood in South Los Angeles. For years, Cox and other residents of Watts would have to ride a trolley downtown and then catch a bus in order to attend Los Angeles City College. The trip took two hours just one way.

According to the Los Angeles Times, Cox surveyed students in all of the area's high schools and found that many of them would go to college if they could get there by foot or bicycle.

The first steps toward the realization of this dream of having a college in the area were taken in 1950 when Cox and others formed a citizen's group -- The South Central Junior College Committee. The diverse group was influential in getting the Los Angeles Unified School District Board of Education, which oversaw Los Angeles community colleges, to purchase 54 acres of land for \$3,500 per acre in 1950 from the Union Oil Company at the corner of Western Avenue and Imperial Highway -- the



eventual site of Los Angeles Southwest College. Another 16 acres would be purchased for \$14,230 per acre from Union Oil in 1964.

A sign was placed on the site in 1950 announcing the college's expected arrival, but many years would pass before construction started.

That day arrived rather quickly after the "Watts Rebellion." During the unrest from August 11-17, 1965, 34 people died - 23 of whom were killed by police and National Guard. Two law enforcement officers and a fireman were among the dead. More than 1,000 people were injured.

A California commission, under Gov. Pat Brown, later determined that the rebellion was caused by police resentment as well as a lack of jobs and educational opportunities for African-Americans.

Sandra Cox, daughter of Odessa Cox, and others believed the riots caught the attention of the Los Angeles Unified School District.

"If there was no rebellion, there would be no Southwest College," Sandra Cox, who currently serves as a Los Angeles Southwest College Foundation member, told the Los Angeles Times in 2001.

In January 1967, the Board of Education would earmark \$2 million to open the college campus at Western and Imperial.

At 3:30 a.m. July 11, 1967, Odessa Cox and her colleagues, including Adele Cannon, Dr. Agnes Moreland Jackson and Sue Acosta, met at Western and Imperial to watch as the first of 13 bungalows were delivered from Los Angeles City College.



Classes started Sept. 11, 1967 with more than 600 students registered and 22 full-time faculty members, according to media reports. LASC's first president was Dr. John Grasham, and the original curricula revolved around liberal arts and academic transfer.

By 1976, LASC had seen a steady growth in its student body as well as faculty, staff and facilities. The number of students had increased to more than 5,000 and the faculty consisted of more than 100. The 13 original bungalows increased to 31 and construction had started on permanent facilities

"I didn't do this alone. I might have conceived the idea, but from the beginning to end it took a lot of dedicated souls to bring the physical property you see today from an idea to a reality ... and it was a team effort all the way," Odessa

**“IT FEELS SO GOOD TO SEE THE THINGS WE  
have fought for for so many years  
FINALLY COMING TO PASS.”**

*Odessa B. Cox*

Cox told The Sentinel newspaper in 2001. "All the way we bolstered one another's spirit, viewed the setbacks as stepping stones and moved ahead."

New facilities were eventually developed, including a library, theater and student services center. They all provided a sense of permanence and symbolism of a new era in higher education in the community.

On Feb. 20, 1987, the college's Building B was renamed the Odessa Cox Building as a result of campaign spearheaded by Los Angeles Community College District Trustee Marguerite Archie Hudson.

LASC would continue to expand in the years ahead with the construction of the Technical Education Center.

"It feels so good to see the things we have fought for for so many years finally coming to pass," Odessa Cox said at the groundbreaking ceremony for the \$7 million center in January 1990.

Her comments were met with a standing ovation, according to media reports.

Currently, the LASC campus is undergoing a major transformation with more than \$400 million in funds from the Los Angeles Community College District Bond Construction Program. The college's modernization efforts include updating existing buildings with new technology and building new "green" facilities.

Additional projects have included the Thomas G. Lakin Physical Education Center, Student Services Building, Child Development Center, athletic stadium and field house, Maintenance and Operations facility, central plant, Cox Annex and a multi-level parking structure.

The campus is also the site of Middle College High School, part of the Los Angeles Unified School District. Many Middle College High students take college courses at LASC to obtain their Associate's Degree while meeting the requirements for a high school diploma.



Evolution of the Spirit  
Community Artist: Elliott Pinkney

Since its opening, LASC has established itself as a key force in the educational, recreational and cultural development for the region. Several academic and occupational programs have distinguished themselves over the years, including the Nursing and Child Development departments.

Today, LASC's student body has increased to more than 8,000. There are more than 300 faculty, staff and administrators looking to help students find academic success.

More and more students each year are also taking part in online Distance Education courses, providing a new avenue in which students are receiving an LASC education.

Odessa Cox passed away in October 27, 2001, but even in her later years, she campaigned for the passage of a bond initiative so the campus could be improved.

On April 2, 2015, the college celebrated the new School of Career and Technical Education building as well as the renovated, modernized and upgraded Cox Building, which includes the remodeled Little Theater and Library.

The vision of Odessa Cox is getting closer to being fully realized.





## INSTRUCTIONAL PROGRAMS

Southwest offers a variety of programs that lead to either an occupational certificate or AA/AS degree. The following chart lists the available programs at Southwest. Please see a Counselor for further details.

**AA-** Associate of Arts

**AA-T** Associate of Arts for Transfer

**SC-** Skill Certificate

**AS-** Associate of Sciences

**CA-** Certificate of Achievement

**AS-T** Associate of Science for Transfer

PROGRAM TITLE	DEGREE	CERT	MAJOR CODE
<b>ART &amp; HUMANITIES:</b>			PAGE 122
Art	AA		1002.00
Art History	AA		1002.01
Communication Studies	AA, AA-T		1506.00
IDS: Arts & Humanities (Opt. 1)	AA		4903.11
IDS: Arts & Humanities (Opt. 2)	AA		4903.12
Music	AA		1004.00
Studio Arts	AA-T		1002.00
Theater Arts	AA, AA-T		1007.00
<b>BEHAVIORAL &amp; SOCIAL SCIENCE:</b>			PAGE 127
Administrative of Justice	AA, AS-T	CA	2105.00
Anthropology	AA, AA-T		2202.00
Chemical Dependency Counselor Program		CA	2104.40
Chemical Dependency Specialist in Criminal Justice		SC	2104.42
Fingerprinting		SC	2105.01
History	AA, AA-T		2205.00
Interdisciplinary Studies (IDS)	AA		4901.01
IDS: Social & Behavioral Science (Opt. 1)	AA		4901.03
IDS: Social & Behavioral Science (opt. 2)	AA		4901.07
Liberal Arts: Administration of Justice	AA		2105.03
Liberal Arts: Psychology of Substance and Abuse	AA		2001.01
Liberal Studies-Teaching Prep ( Opt. 1)	AA		4901.23
Liberal Studies-Teaching Prep (Opt. 2)	AA		4901.20
Pan American Studies	AA		2201.00
Political Science	AA, AA-T		2207.00
Psychology	AS, AA-T		2201.00
Recovery Specialist		SC	2104.41
Social Services		SC	2208.00
Sociology	AA, AA-T		2208.00
Teacher Assistant		SC	801.01
<b>BUSINESS:</b>			PAGE 138
Banking and Finance		CA	504.00
Bookkeeping		SC	502.01
Business Administration	AS-T		505.00
Business Administration: Accounting/ General Business	AA		501.00
Business Administration: Business and Finance	AA		504.00
Business Administration: Economics	AA		505.01
Business and Office Technology		SC	514.04
Certified Internet Webmaster Associate (CIWA)		SC	709.01
Computer Applications and Office Technology	AS		514.00
Computer Science: Information Technology	AS		707.10
Computer Network Cabling Technician		SC	934.02
Computer Technician		SC	-
Economics		SC	505.00
Electronic Technician		SC	-
Electronics Technology	AS		934.00
Finance		SC	504.01
General Business		CA	501.00
General Office Assistant		SC	514.02
Homeland Security and Computer Network		CA	701.00

PROGRAM TITLE	DEGREE	CERT	MAJOR CODE
Homeland Security Network Administrator		CA	701.01
Income Tax Form Preparation		SC	502.02
Law Office Specialist 1		SC	1401.02
Law/Paralegal	AA		1402.00
Legal Office Assistant		SC	514.10
Liberal Arts: Computer Applications & Office Technology	AA		702.10
Liberal Arts: Computer Science	AA		706.00
Liberal Arts: Electronics	AA		934.01
Liberal Arts: Real Estate	AA		511.00
Management		SC	506.30
Management/Supervision	AA	CA	506.30
Microsoft Excel		SC	514.05
Microsoft Word		SC	514.09
Real Estate: Broker		CA	511.00
Real Estate: Escrow		SC	511.03
Real Estate: Salesperson		SC	511.04
Receptionist		SC	514.06
Small Business Entrepreneurship I		SC	506.31
Small Business Entrepreneurship II		SC	506.32
Supervision		SC	506.33
Telecom and Network Technician		SC	934.00
Web Site Designer		SC	709.02
Word Processing		SC	514.03
<b>CHILD DEVELOPMENT:</b>			Page 150
Associate Teacher (Formerly: Teacher, Private Lic Preschool)		SC	1305.01
Child Development	AA		1305.00
Children with Special Needs (Formerly: Teacher, Private Lic. Preschool-Differently Abled)		SC	1305.13
Early Childhood Education	AS-T		1305.00
Infant and Toddler Studies (Formerly: Teacher, Private Lic Preschool-Infant Toddler)		SC	1305.14
Liberal Arts: Child Development	AA		4901.02
School Age Program (Formerly: Teacher, Private Lic Preschool-School Age)		SC	1305.15
<b>ENGLISH &amp; FOREIGN LANGUAGES:</b>			Page 141
English	AA, AA-T		1501.00
Liberal Arts: English	AA		1501.01
Journalism	AA, AA-T		602.00
Professional Spanish		SC	1105.05
Spanish	AA, AA-T		1105.00
<b>MATHEMATICS:</b>			PAGE 151
Mathematics	AA, AS-T		1701.00
Mathematics: Computer Science			1701.01
<b>NATURAL SCIENCE, HEALTH &amp; KINESIOLOGY:</b>			PAGE 166
Biology	AA		401.00
Geography	AA		2206.00
Geology	AA		1914.00
Liberal Arts: Natural Sciences	AA		4901.04
Physics	AS, AS-T		1902.00
<b>NURSING:</b>			PAGE 170
Certified Nursing Assistant/Home Health Aide		CA	1230.30
Nursing	AS		1203.00

## EDUCATIONAL PHILOSOPHY

The Los Angeles Community College District (LACCD) affirms the principle that individuals should have opportunities to develop to their fullest potential. To that end, the district colleges' main responsibility is to students and to the provision of education, which benefits students and enables them to contribute to society.

LACCD colleges, therefore, are accessible to all individuals who have the capacity and motivation to profit from higher education. Curricula and services of LACCD colleges provide means for fulfilling the promise of open access.

We recognize the necessity to adapt to the changing educational needs of the Los Angeles Community College District's communities and to the growing diversity among students.

The quality of the educational experience is to be judged by its value to our students and the communities. We recognize that academic freedom is essential to excellence in education.

### FUNCTIONS OF THE COMMUNITY COLLEGE

To accomplish the educational philosophy and mission of the Los Angeles Community College District, LASC offers the following types of educational programs:

**Transfer.** A college transfer program that enables a student who completes two years of study to continue upper division (third year) work at accredited four-year colleges and universities through careful and continuous articulation with accredited collegiate institutions and high schools.

**Career and Technical Education (CTE).** CTE provides open access to career preparation through noncredit programs, for-credit certificate and degree programs leading directly to employment; transfer programs that prepare students for transition to four-year institutions; programs to enhance skills of incumbent workers and for retraining of incumbent and re-entering workers.

**General Education.** A program of general education is comprised of associate degree programs and other planned experiences that develop knowledge, skills and attitudes necessary for a student to be effective as a person, family member, employee, and citizen, thereby enhancing the quality of life for the individual and for society-at-large.

**Transitional Education.** A program of remedial and basic skills education for students needing preparation for community college level courses and programs as well as English as a Second Language instruction for immigrants, foreign students and other students with limited English proficiency.

**Continuing Education.** Comprised of graded and ungraded classes to provide opportunities for personal and occupational competence that supplement formal full-time college attendance.

**Community Services.** Community services meets the needs of the community for vocational and recreational courses, community and cultural events, as well as summer youth programs and civic functions, which are all completely financed by fees charged to those in attendance.

**Joint Programs.** Joint programs with business, industry, labor, education, government and other institutions, are of mutual benefit to sponsoring institutions, enhance the



educational opportunities of program participants, and advance the mission and functions of the District.

## LASC MISSION & GOALS

In honor of its founding history, Los Angeles Southwest College provides a student-centered learning environment committed to empowering students and the community to achieve their academic and career goals through the attainment of certificates and associate degrees leading to transfer and workforce preparation.

### Los Angeles Southwest College Strategic Goals

- 1. Access and Preparation for Success:** Improve equitable access to a high-quality education that promotes student success.
- 2. Success:** Increase student success and academic excellence with a focus on student-centered instruction and support services.
- 3. Institutional Effectiveness and Accountability:** Enhance institutional effectiveness and accountability through data-driven decision making, as well as planning, evaluation, and improvement of college programs, professional development opportunities, and governance structures.
- 4. Resources:** Optimize human, physical, technological, and financial resources to ensure quality services for our students.
- 5. Collaboration and Partnerships:** Maximize collaboration within the college while cultivating and strengthening partnerships with industry, community, and other educational institutions.

### Core Values

- **Accountability and Integrity:** We are accountable to our community through the ethical implementation and assessment of our mission and vision, and in the responsible management of our resources.
- **Collegiality:** We work actively to create communities of mutual respect and shared concern that support and sustain open debate and progressive discourse.
- **Excellence and Innovation:** We strive to create a culture of excellence and continuous improvement through the use of innovative pedagogy and technologies that challenge our students, faculty, staff, and administrators to meet the highest educational and professional standards.
- **Student Learning and Success:** We respond to the needs of students by creating a learner-centered environment that promotes student success and academic excellence.
- **Civic Engagement:** We provide quality services and opportunities to tomorrow's leaders by encouraging public awareness and participation in the community.

### Accountability

LASC assumes and demonstrates accountability by:

- Addressing and implementing the standards of accreditation
- Meeting or surpassing professional and ethical standards
- Being responsive to the needs of students by continuously evaluating and improving policies and procedures.

### Respect

LASC fosters respect, civility and courtesy by:

- Creating an environment of trust where differences are recognized and respected;



- Supporting and acknowledging the contributions and needs of students and employees;
- Treating individuals with dignity.

### Integrity

LASC is dedicated to upholding ethical standards and striving for integrity by:

- Interacting with truth, sincerity, respect and collegiality;
- Respecting and promoting principles of collaboration and shared governance;
- Serving with the highest level of ethical behavior.

### Excellence

LASC supports the pursuit of excellence by:

- Its dedication to students, tasks, and the mission of LASC
- Surpassing requirements and expectations
- Modeling best practices and maintaining currency in area(s) of specialization and service.

### Equity

LASC is committed to promoting equity by:

- Understanding and being responsive to differences in learning modalities
- Promoting access to all who can benefit from the learning opportunities provided by LASC
- Ensuring fair and equitable treatment to students and employees.

## STUDENT LEARNING OUTCOMES

Student Learning Outcomes (SLOs) represent knowledge, skills, and/or attitudes gained by students as a result of a college experience. Not only do colleges need to demonstrate a concerted effort to develop SLOs at the course, program, and institutional (degree) levels, but also outcomes should be measured (or assessed) to determine how well learning is taking place so that learning and teaching can be improved.

**Course Level SLOs**—Represent knowledge, skills, and/or attitudes gained by students as a result of completing a course. These SLOs are included in course syllabi.

**Program Level SLOs**—Represent knowledge, skills, and/or attitudes gained by students as a result of completing a program. An academic program can be defined as a series of courses that lead to a specific degree or certificate. Program level SLOs are also linked to disciplines involved in program review and can also denote non-academic centers that provide a specific service to students (e.g., Financial Aid Office, EOPS, etc.).

**Institutional Level SLOs**—Knowledge, skills, and/or attitudes that all students should acquire as a result of their educational experience at LASC. General education SLOs may be included in this category.

For more information about SLOs, visit the SLO Committee website at [http://portal.lasc.edu/as/SLOCom/\\_layouts/15/start.aspx#/SitePages/Home.aspx](http://portal.lasc.edu/as/SLOCom/_layouts/15/start.aspx#/SitePages/Home.aspx).

## LASC INSTITUTIONAL STUDENT LEARNING OUTCOMES

Institutional student learning outcomes, or institutional SLOs, are the knowledge, skills, and abilities a student is expected to leave an institution with as a result of a student's total experience. These outcomes may also be equated with GE (General Education) outcomes.

- 1. Communication (Oral and Written Skills)**  
Use language (oral and written) and non-verbal modes of communication appropriate to the audience and purpose.
- 2. Cognition (Reading Comprehension, Computational Skills, and Critical Thinking)**  
Use critical thinking and computational skills to analyze, synthesize, and evaluate ideas and information.
- 3. Information Competency (Information Competency and Technological Literacy)**  
Utilize research skills necessary to achieve educational, professional, and personal objectives.
- 4. Social Responsibility (Responsible Citizenship and Valuing Diversity)**  
Demonstrate sensitivity to and respect for others and participate actively in group and civic decision making.
- 5. Personal and Professional Development (Employability and Confidence Building)**  
Demonstrate self-management, maturity, and growth through practices that promote physical, mental, and emotional well-being.





## LASC FOUNDATION

The Los Angeles Southwest College Foundation is the focus of community and corporate support for LASC. The foundation is a nonprofit, tax-exempt 501(c)(3) corporation. Its purpose is to receive and administer private gifts and donations to benefit LASC students and to enhance the quality of education at the college. Contributions to the foundation qualify for state and federal tax deductions and for estate tax savings. The foundation is governed by a volunteer board of directors. The Los Angeles Southwest College Foundation encourages the formation of partnerships and welcomes tax-deductible contributions to support the college's mission and goals.

Businesses, agencies, persons, and friends who would like to make contributions, serve as volunteers, or wish to donate supplies or equipment in support of the many programs at LASC may contact:

Los Angeles Southwest College Foundation  
1600 West Imperial Highway  
Los Angeles, CA 90047-4899  
Phone: (323) 242-5273 Fax (323) 241-5220  
Email: [lasc\\_foundation@lasc.edu](mailto:lasc_foundation@lasc.edu)



## HOW TO USE THIS CATALOG

Use this catalog as a road map through your academic program and community college experience. Throughout the catalog, you will find information about Los Angeles Southwest College's academic programs, academic standards, District policies, and helpful information regarding student-support services and student life.

Use the catalog to:

- **Learn about our academic program offerings.** For each program, you will find information about program requirements, required and elective courses, potential career and/or transfer opportunities, expected learning outcomes, and graduation requirements. Academic advisors and counselors are available to help you learn more about programs that are aligned with your interests, work skills and personal goals.
- **Follow the Student Success and Support Program process.** Read the "Attending LASC" section, page 17, to familiarize yourself with the steps required to become a student at LASC.
- **Explore course descriptions.** Proper course selection begins with knowing what a course is about and how it will fit into your academic program.
- **Plan for transfer to a four-year college or university.** Transfer opportunities and services information can assist you as you select your coursework and make decisions about moving ahead in your academic career.
- **Prepare for entry into your selected career.** Visit the [Career Center](#) and [Career & Technical Education](#) for insight into how to select and prepare for a career.
- **Become a successful student.** Many resources are available at LASC to help you succeed. Visit the [Student Life](#) and [Student Resources](#) sections on our website to learn more about tutoring, assistance programs, and other services that can help you. Also, review the [Academic Calendar](#), [Academic Standards](#), and [District Policies](#) sections for important information that will help you remain in good academic standing.
- **Learn campus offerings, policies and procedures.** The catalog will help you locate resources and assist you in becoming familiar with policies and procedures. Use the Table of Contents and the Index to locate information on Admissions, Financial Aid, and much more.

*The college catalog is essential for academic planning. It is a useful supplement for career and course advising and guidance. While the information in this catalog is current at the time of publication, LASC reserves the right to change or delete any courses of study, course offerings, schedule, tuition, and other charges, policies or programs of the College at any time and without any notice. The LASC Catalog is published online annually. Information about courses and programs may be modified throughout the year. Students should always consult with an academic advisor or counselor to ensure that the most current information is available when making academic decisions.*

## 2016-2017 COLLEGE CALENDAR

FALL 2016 SEMESTER	
Instruction Begins	August 29, 2016
Labor Day	September 5, 2016
Graduate/Certificate Petitioning	September 13-October 21, 2016
Veterans Day	November 11, 2016
Thanksgiving	November 24-25, 2016
Final Examinations	December 12-16, 2016
Fall Semester Ends	December 18, 2016
WINTER INTERSESSION 2017	
Instruction Begins	January 3, 2017
Martin Luther King, Jr. Day	January 16, 2017
Winter Intersession Ends	February 5, 2017
SPRING SEMESTER 2017	
Instruction Begins	February 6, 2017
Presidents' Holiday	February 17-20, 2017
Graduate/Certificate Petitioning	February 22-March 30, 2017
Cesar Chavez Day	March 31, 2017
Spring Break	April 1-7, 2017
Memorial Day	May 29, 2017
Final Examinations	May 30 - June 5, 2017
Spring Semester Ends	June 5, 2017

Always refer to LASC's Schedule of Classes for the most current calendar dates for each semester.





# Admissions and Registration

## ATTENDING LOS ANGELES SOUTHWEST COLLEGE

Admission to Los Angeles Southwest College is open to everyone. Adding to the diversity and richness of LASC, our student body consists of high school and adult learners, and international students. Students may enroll in day, evening, weekend classes or online courses to meet their academic goals. Students may enroll full-time or part-time while completing a degree or certificate program, or take courses on an individual basis. LASC welcomes applications from California residents as well as out-of-state and international applicants.

### **Admission & Registration How to Apply and Enroll at LASC**

All new students are expected to participate in the Student Success and Support Program (formerly Matriculation) process prior to registering for classes. Orientation, Assessment, and Advisement are essential parts of this process. All students enrolling for the first time in any English, English as a Second Language, reading, or Mathematics class must complete the appropriate assessment test and should contact the Student Success and Support Program Office.

Students should plan on completing the Application and Registration process in the following steps:

#### ***Step 1 – Apply for Admission***

Complete and submit an Application for Admission in the Admissions Office, Student Services Building (SSB), Room 102, or apply online at [www.lasc.edu](http://www.lasc.edu) and click the “Apply Online Today” link.

#### ***Step 2 – Attend Orientation***

The in-person orientation will introduce you to LASC, our policies and procedures as well as give you an overview of the different resources and support services and campus tour that are available for your success. Check the posted schedule at the Student Success and Support Program website for dates, room locations, and times.

Students may also complete the Online Orientation by visiting [www.lasc.edu](http://www.lasc.edu), the link is available on the homepage.

#### **NOTE TO TABLET USERS:**

The orientation program is built using Flash, but this won't prevent you from using your tablet to view the presentation. You can visit either Google Play (Android) or the Apple App Store (iOS) and download a cloud-based browser.

#### **FOR STUDENTS USING SCREEN READERS:**

After selecting the accessible version option, you need to turn your screen reader off. There are built-in accessibility functions within the orientation program that conflict with screen reader commands. If you do not turn off your screen reader, the built-in accessible features will not work properly.

#### ***Step 3 – Go to the Assessment Center***

Trained staff in SSB, Room 204 will help guide you through the registration process. You may



be asked to take the assessment test, which includes multiple measures such as reading, writing, arithmetic, elementary algebra, and college-level math tests. No children are allowed in the testing area. The schedule for testing and any additional information is available each semester in the Student Success and Support Program Office or in the Admissions and Records Office.

#### **Step 4 – See a Counselor**

You must see a counselor for assistance with completing your student educational plan. The counselor will assist you in selecting appropriate classes that meet your educational goals. All financial aid recipients must declare a major and have a student educational plan on file.

Counselors are available in the following areas:

- General Counseling - SSB Room 227
- CalWORKs - SSB Room 217
- Disabled Students Program & Services (DSPS) - SSB Room 117
- EOPS - SSB Room 218
- Freshman Year Experience - SSB Room 228
- International Students - SSB Room 209
- Passage Program - SOCTE Room 138
- Puente Program - SSB Room 218
- TRIO Scholars - SSB Room 229
- TRIO STEM - SSB Room 229
- Veterans Resource Center - SSB Room 207

#### **Step 5 – Register for Classes**

Registration is by appointment only. Register online or in-person on or after your assigned registration appointment time and date. Log into the Student Information System to view your assigned registration date and time. For your convenience, registration instructions are posted inside the Schedule of Classes. LASC encourages all new students to enroll in a Counseling class.

#### **Step 6 – Apply for a Fee Waiver**

Visit the Financial Aid Office in SSB, Room 104 to apply for a fee waiver. If you qualify, the waiver can be used to pay your fees for the entire academic year. The waiver cannot be used to pay your \$11 health fee and/or ASO representation fee.

#### **Step 7 – Pay Your Health/Parking Fee and Pick Up the Fee Receipt**

Visit the Business Office in SSB Room 103 to pay your health fee, ASO representation fee, ASO membership, purchase a parking permit (if needed), and pick up your fee receipt.

#### **Step 8 – Take Your Student ID Picture**

Once you have registered for classes you are eligible to receive a free student ID from the Student Success and Support Program Office in SSB, Room 204. You must bring a copy of your fee receipt, which lists your classes, and a photo identification. (drivers license or California ID).

## ADMISSIONS AND RECORDS

[www.lasc.edu/students/admissions/admissions.html](http://www.lasc.edu/students/admissions/admissions.html)

Office of Admissions and Records  
Student Services Building (SSB), Room 102  
323-241-5321

Kimberly Carpenter, Registrar  
Luciana Peralta, Admissions & Records Evaluator Technician

### Admissions & Records Assistants

Oscar Paniagua  
Leilani Piernas  
Emilia Solval

Admission to LASC is open to high school graduates, individuals with a high school equivalency certificate (GED), or anyone 18 years of age or older and can show evidence of being able to benefit from instruction. All inquiries concerning application, admission, and registration should be sent to Los Angeles Southwest College, Office of Admissions and Records, 1600 West Imperial Highway, Los Angeles, CA 90047-4899.

### **Application for Admission**

Applications for admission with detailed instructions are available from the Office of Admissions and Records and on the college's website at [www.lasc.edu](http://www.lasc.edu). Click on the "Apply Online" link. An application must be submitted if a student is:

1. A new student entering LASC for the first time (who is not a current student at a sister campus).
2. A returning (former) student who did not attend LASC or a sister campus for the prior fall semester or spring semester,
3. A student in grades K-12 enrolled in a public or private school seeking special admission.

### **Required Student Fees**

Enrollment	\$46 per unit
Health Services -Spring/Fall Semester -Summer/Winter	\$11 per semester \$8 per semester
Associated Students Organization Fee*	\$7 per semester
ASO Student Representation Fee*	\$1 per semester

The ASO Student Representation fee is used for a variety of events and activities that represent student viewpoints on and off campus. The Student Representation Fee is mandatory; however, students may opt out of paying the fee based on religious, political, financial or moral reasons. Students who refuse to pay the fee must submit their request in writing.

### **Health Fees**

In addition to enrollment fees, all students will be charged a health fee (\$11 for fall, \$11 for spring, \$8 for summer, and \$8 for winter). The health fee will not be waived for students eligible for a fee waiver. For any question, contact the Financial Aid Office at (323) 241-5338.



## Student Representation Fee

During the Associated Students Organization (ASO) elections on April 17-18, 2012, Los Angeles Southwest College students passed the Representation Fee of \$1 per semester. Education Code Section 76060.5 allows the ASO to conduct an election to establish a student representation fee of one dollar (\$1.00) per semester.

The fee will support governmental affairs representatives who will state their positions and viewpoints before city, county, district governments, and offices and agencies of the state government. ASO plans to use these funds to send LASC students to the State Capitol in Sacramento to advocate on behalf of all students for more funding and initiatives that increase student success. These funds will also be used for advocacy training for LASC students.

## K-12 Students Special Admission

Educational enrichment opportunities are available for students who would benefit from advanced scholastic or vocational work as agreed by the President or designee. These students, upon recommendation of the principal of the school that the student attends and with parental consent, may attend a community college as special part-time students to undertake one or more courses of instruction offered at the community college level.

The student can earn credit toward high school graduation and a college degree. Application packets are available at the Admissions Office or on the college's website. A photo ID must be presented with the K-12 Supplemental Application for Admission. Consult the Schedule of Classes for K-12 application deadlines. For more information, call (323) 241-5321. Interviews may be required by the college.

LASC reserves the right to exclude or limit enrollment into impacted programs and in other programs where health, safety, instructional methodology, facility constraints, or legal requirements are deemed inappropriate for special admission students.

Special admission students must conform to LASC's academic rules and regulations and the code of conduct expected of all college students. Some fees may be required.

## Fee Exemption for Special Part-Time Students, Grades K-12

Students admitted to the Los Angeles Community College District pursuant to Education Code Section 76001 and Section 8100.01 of the Board Rules as special part-time students who are concurrently enrolled in K-12 are exempt from enrollment fees and non-resident tuition fees charged for all terms (including summer) pursuant to Education Code Section 76300(f) and 76140(a)(4).

## Residency

The California residency requirement has two parts: 1) Act and 2) Intent. To claim residency, a student must have legal immigration standing, have lived and shown intent to reside in California by a) paying California income taxes, b) possessing a valid California driver's license, c) registering and voting in the state, d) owning and registering a car in California, and/or the absence of these ties with another state. The payment of California state income taxes is the most important act of intent. Concurrent with the act of intent, physical presence in the state for one year and one day prior to the residency determination date is required to establish California residency. Students with questions about the process should contact LASC's Office of Admissions and Records.

Residency status is determined by the answers to certain questions in the application for

admission. It is for this reason that all college applicants should complete the application as thoroughly and accurately as possible. Inaccurate information may cause a student to be classified as a non-resident, and, if this occurs, the burden of proving California residence status is on the student.

### **Change of Address**

When students change their place of residence after applying for admission to the College, they must change their address at the Office of Admissions and Records immediately by preparing a Notice of Change of Address.

### **Residence Appeal**

Students may appeal their residence classification determined by LASCC. The Residence Appeal must be made within 30 calendar days of receipt of notification of the residence classification from the Office of Admissions and Records. The Residence Appeal must be submitted in writing to the College Admissions Officer.

### **Residence Reclassification**

Students will be notified of residency classification within 14 calendar days of submission of application. Students who feel they are classified as a non-resident in error have 30 days from the date of notice to appeal by submitting a residency reclassification form along with required documentation.

A student classified as a non-resident may petition to be reclassified as a resident at any time they feel their status has changed. The Residence Reclassification form is available in the Admissions Office and must be submitted prior to the semester in which reclassification as a resident is to be effective.

## [Enrollment Fees and Non-Resident Tuition](#)

### **Enrollment Fees for California Resident Students**

Section 72252 of the Education Code requires community colleges to charge an enrollment fee of each student enrolling in college. The Office of Admissions and Records determines residency status for all students. The 2016-2017 enrollment fee for California residents is \$46 per unit. Enrollment fees may be waived for students who are eligible for a Board of Governors Fee Waiver (BOGFW).

### **Enrollment Fee Assistance**

The Board Financial Assistance Program is offered by the California Community Colleges. Under this program, enrollment fees are waived for students who qualify. Students do not have to be enrolled in a specific number of units or courses to receive the Board of Governors Fee Waiver (BOGFW). Non-resident students are not eligible for the BOGFW.

Some students may qualify for additional types of fee waivers. Refer to the Financial Aid section of the College Catalog and the Financial Aid Office for more information about enrollment fee waivers and the range of financial aid options available to students. We encourage all students to apply for financial aid using the FAFSA so that they will be considered for all of the federal and state financial aid programs.



## Enrollment Fees and Tuition for Non-Resident Students

A non-resident student is one who has not had residence in the State of California for more than one year immediately preceding the Residence Determination Date. Residence is defined as a union of act and intent. Physical presence alone is not sufficient to establish California residency, nor is intent when not coupled with continuous physical presence in the state. Certain non-U.S. citizens are permitted to establish residency and certain others are not. Check with the Office of Admissions and Records regarding your particular status.

A student classified as a non-resident will be required to pay current enrollment fees (\$46 per unit) and the non-resident tuition fees as established by the LACCD Board of Trustees. However, certain non-resident students may be exempt from paying non-resident tuition fees based on the AB 540 Exemption. In addition, undocumented students who do not qualify for the AB 540 Exemption may be entitled to exemption from non-resident tuition fees on the basis of individual financial need in accordance with regulations established by the LACCD Chancellor. If these students meet the eligibility requirements on the Non-Resident Tuition Fee Waiver (available in the Office of Admissions and Records, Financial Aid, and Bridges To Success offices), they may be eligible to receive a non-resident tuition exemption and pay only the current enrollment fee of \$46 per unit. Non-resident students are not eligible for the BOGFW.

The Board of Trustees adopted a non-resident tuition of \$190 per semester unit for students attending LACCD colleges who are non-residents of the state. Foreign students must pay non-resident tuition in addition to a capital outlay fee of \$22 per semester unit, for a combined total of \$212 per unit. These fees are subject to change each academic year.

**NOTE:** Non-resident students are required to pay community college enrollment fees as described in the enrollment fees section of this publication and the non-resident tuition. Non-resident students are not eligible for the BOGFW.

### California Non-Resident Tuition Exemption for Eligible High School Graduates (AB 540, AB 131 and AB2000 Exemption)

On October 12, 2001, California Education Code was modified to exempt certain non-resident students, including undocumented students, who attended and graduated from California high schools from paying non-resident tuition fees at any public California Community College. This change (Education Code, Section 68130.5) does not grant residency; rather it requires that certain non-resident students be exempt from paying non-resident tuition. Students exempt from paying non-resident tuition do not become residents for eligibility purposes for any state-funded program (e.g., EOPS, Board of Governors Fee Waiver, Cal Grant and/or the Governor's Merit Scholar Program).

To be eligible, all U.S. citizens, permanent residents of the US, and aliens who are not non-immigrants (including those who are undocumented), and who meet all of the following eligibility requirements:

1. The student must have attended (1) a high school (public or private) in California for three or more years, or (2) attended elementary or secondary school in California for a total of three or more years and attained credits earned in California from a California high school equivalent to three or more years of full-time, high-school coursework. There are no provisions for partial attendance (e.g., two years and 7 months).
2. Attendance in the 9th grade in a California high school is acceptable for one of the three years of high school attendance, even if that school was designated as a "middle" school.
3. Students are not required to have consecutive attendance nor required to have attended

the last three years in California (in the case of four-year high schools).

4. Attendance may be at multiple California high schools.
5. Attendance at continuation high schools, charter high schools, independent study at the 9th-12th grade level while enrolled in a California public school, including a charter school, and private tutoring provided by a person holding a valid California teaching credential (and meeting other state requirements) are recognized under state law as acceptable manners in which to attend high school.
6. Home schooling is instruction by a tutor or other person (including the student's parent) who does not have a valid California teaching credential. Local high schools are charged with determining whether to accept home schooling as valid attendance. To consider home schooling as high school attendance for purposes of granting the exemption, the college should consult with the public high school the student would have attended if he/she was not home schooled. If that high school accepts or would accept home schooling as valid high school attendance, the community college should also accept it for purposes of assessing whether the student can demonstrate three years of high school. The Chancellor will develop procedures for communicating with high schools and validation of acceptability of home schooling toward meeting this requirement.
7. In most cases, attendance in adult education classes does not qualify as high school attendance. However, attendance in adult education classes through a secondary adult school as an "evening high school" satisfies the requirement for high school attendance for purposes of Section 68130.5. School districts should be able to confirm whether their adult schools were established and designated as "evening high schools." Additional assessments may need to be made as to other types of adult education attendance. For example, attendance at a secondary adult school for purposes of completing a high school diploma may be acceptable.
8. The law does not distinguish between public and private high schools.
9. There is no time limit on how far in the past the student might have attended a California high school.
10. The student must have graduated from a California high school or attained the equivalent thereof (e.g., passing the GED or California High School Proficiency exam or certificate of completion issued pursuant to Education Code section 51412). The GED or high school proficiency exam must be from California. There is no time limit on how far in the past the student might have attained this status.
11. Under some limited circumstances students may be eligible for an exemption from nonresident tuition even though they have not passed the high school exit exam and received a high school diploma. In particular, a student with a disability (other than a nonimmigrant) who has received a certificate of achievement issued by a high school pursuant to Education Code section 56390 should be considered to have satisfied the high school exemption from nonresident tuition if he/she meets all other requirements of the statute. A student who attends high school for three years in California and receives a certificate of completion from a California high school is eligible for the exemption from nonresident tuition, provided that the document from the high school either states that it is issued pursuant to Education Code 51412 or explicitly certifies that the student has completed the course of study and met the proficiency standards prescribed by the governing board of the high school district.
12. A student who files the affidavit shall not be asked to provide additional evidence of immigration status unless the college is in possession of evidence that casts doubt on the validity of the affidavit. The college is not required to monitor future changes in such eligibility.
13. If the student has an application with the United States Citizenship and Immigration Service (USCIS) to change his/her status to a classification that permits establishing residency, the student may already be eligible for resident fee status if the student has resided in California for more than one year since the time of the application to USCIS.
14. Students who hold visas as nonimmigrant aliens (the most common being the F series





student visas and B series visitor visas) are not eligible for this exemption. However, “T” (victims of human trafficking) and “U” (victims of certain crimes) visa holders may be eligible.

15. Students who previously held valid nonimmigrant visas but who are out of status at the time of execution of the affidavit are eligible for the exemption.

16. An alien student who is without lawful immigration status must file an affidavit with the college or university stating that he or she has filed an application to legalize his or her immigration status or will file an application as soon as he or she is eligible to do so.

Non-resident students meeting the criteria will be exempted from the payment of non-resident tuition, but they must pay the current enrollment fee of \$46 per unit. These students will not be classified as California residents. They will continue to be “non-residents.” The California Dream Act extends Cal Grant A and B entitlement awards, Cal Grant C awards, Chaffee grants, and institutional financial aid to students who meet these criteria as well as applicable criteria for eligibility for specific types of financial aid. AB 540 does not provide federal student financial aid eligibility for undocumented alien students. These students remain ineligible for federal financial aid.

AB131 allows undocumented students who meet AB 540 eligibility requirements to apply for financial aid via the California Dream Act application. AB540 eligible students who are granted DACA status have taken appropriate steps to obtain a change of status from the applicable federal agency to a classification which does not preclude establishing domicile. Thus, for residency determinations made on or after June 5, 2014, if the student otherwise meets the requirements of California law related to physical presence and the intent to make California home for other than a temporary purpose, the student can be classified as a resident for purposes of assessing tuition, awarding Board of Governors Fee Waivers, and determining eligibility for services that require California residency.

### **International Students (F-1 Visa) Admission**

Los Angeles Southwest College is certified by the Department of Homeland Security to issue I-20s to non-immigrant visa students. Applicants must meet the following requirements:

1. Have earned a high school diploma or the equivalent education in a foreign country
2. Have a good command of the English language as demonstrated by a score of 450 or higher on the TOEFL. If the computer-based TOEFL is taken, the total score must be at least 133 or 45 if the online version is taken. Also accepted are the IELTS Band 5 or higher and the STEP Eiken for Japanese students at Level 2 or higher.
3. Show the ability to pay the non-resident tuition, enrollment fees, and living and personal expenses for 12 months. Personal and living expenses may be substituted with a certification from a U.S. sponsor who provides free room and board to the student.
4. International student applications are accepted for each fall and spring semester. Direct inquiries may be made to the international student coordinator at (323) 241-5277. You may also view information regarding the International Student Program at [www.lasc.edu/students/international/prospective.html](http://www.lasc.edu/students/international/prospective.html)

Effective April 12, 2002, the Bureau of Citizenship and Immigration Services issued an Interim Rule that requires students with B visas to change their visa status to either F-1 or M-1 prior to pursuing a course of study at the college.

### Optional and Additional Fees

Out-of-State Tuition (students outside CA)	\$190 per unit
International Tuition (foreign students)	\$207 per unit
International Medical Insurance Fee	\$522
Preferred Parking Permit	\$27 (\$20 with ASO)
General Parking Permit	\$20
Transcripts	\$3 (\$10 for RUSH)
Duplicate Registration Receipts	\$1

### Enrollment Fee Refund Policy

**For full-term courses:** The student will receive a full refund up to the end of the second week of classes. There will be no refunds after that unless the student must drop a class because it is canceled or rescheduled by the college. After the second week of classes, the student may drop a course and use the fee to add another class. Therefore, we advise the student to drop and add at the same time. After the second week of classes, there will be absolutely no refunds even when the class added has fewer units than the class dropped. It is the student's responsibility to drop classes.

**For short-term courses:** The student will receive a full refund up to the end of a period of time equal to 10 percent of total class time. There will be no refunds after that, unless the student has to drop a class because it is canceled or rescheduled by the college.

### Non-Resident Tuition Refund Criteria and Schedule

A non-resident student who formally drops or otherwise separates from part or all of his/her enrollment may request a refund of previously paid non-resident tuition in accordance with the schedule below. Such a request must be made in writing on a form provided by the college. The date used for non-resident refund purposes is the date the request is filed and time stamped, regardless of when separation may have occurred. All non-resident refunds will be made by mail.

Non-resident refunds will be computed as follows:

CLASS TYPE	DATE REQUEST TIME STAMP	TUITION REFUND
Full Term (Fall, Spring)	Through the second week of instruction	Full
	After second week of instruction	None
Short Term (Summer, Winter, 8 Week)	Through 10% of class length	Full
	After 10% of class length	None. Aid will be returned to the program.

### Transcripts

#### Ordering Transcripts

Requests for transcripts or verifications may be obtained in the Office of Admissions and Records. Upon written request by the student, a copy of the student's academic record shall be forwarded to the student or his or her designated addressee promptly by U.S. mail. A student or former student shall be entitled to the first two copies of the transcript of his or



her record or two free verifications of the student records in his/her lifetime free of charge. Additional copies shall be made available to the student, or to an addressee designated by the student, at a cost of \$3 per copy.

Students may request rush processing (in person only) to expedite their request for an additional fee of \$7 per copy. Rush transcripts will only be addressed to the student and will indicate "Issued to the Student." Some receiving institutions may consider these unofficial.

The student's transcript may be withheld if 1) any library books or other library materials are charged to the student and are unreturned, or 2) there are any unpaid fees or charges due to the college. The transcript may be withheld until these obligations of the student to the college are discharged.

### **Ordering Transcripts Online**

To request a transcript online, you are required to pay the transcript fee with a valid debit or credit card. In addition to the \$3 transcript fee, and, if requested, the \$7 Rush Processing Fee, The National Student Clearinghouse (NSC) charges a \$2.55 convenience fee per copy, for processing an online order. Log on to the Student Information System and access "Transcripts & Enrollment Verifications." You may also order online 24/7 directly through the NSC website. The online transcript ordering service should not be used for "Rush" transcripts that you wish to pick up in person, or to obtain the two free transcripts.

### **Transcripts from Other Colleges**

Coursework taken at institutions outside the Los Angeles Community College District must be documented with an official transcript filed in the Office of Admissions and Records. The Office of Admissions and Records does not accept official transcripts from students. All official transcripts must be mailed to the Office of Admissions and Records directly from the institution of origin. All incoming transcripts become the property of the Office of Admissions and Records and are not available for copying.

Advance Placement (AP)/ College-Level Examination Program (CLEP) scores must be received in Admissions and Records directly from the issuing institution.

### **Evaluation of Foreign and International Transcripts**

The intent of this policy is to provide a process for granting Associate Degree credit for course work completed at institutions of higher education outside the United States, which are deemed comparable or equivalent to the first two years of college. Credit is authorized for work completed at these institutions under the provisions of this regulation.

1. After completion of 12 units within the Los Angeles Community College District with a "C" (2.0) or higher grade-point average, students may submit a petition to have coursework completed at institutions of higher education outside the United States accepted by the College.
2. A maximum of the equivalent of 30 semester units may be accepted for coursework completed at an institution of higher education outside the United States.
3. Students petitioning for credit must provide an evaluation of their transcripts completed by an independent transcript evaluation service approved by the California Commission on Teacher Credentialing.
4. In order to be considered for elective (unit) credit, the evaluation of the student's transcript, conducted by the independent transcript evaluation service required by section 3 of this regulation, must include the following:
  - a. Description of the country's higher education system and the role of the institution in that system.
  - b. Verification that the institution is approved by the appropriate approving/accrediting agency within that country (e.g., ministry of education).
  - c. The hours completed and their semester-unit equivalences.
  - d. Grades—U.S. equivalent (i.e., A-F), Pass/No-Pass, or percent- age, including the



percentage required for a passing grade.

Note: Unless the provisions of Section 5 of this regulation are also met, only elective credit may be granted.

5. The college may also grant course equivalency, in keeping with college procedures for determining whether the courses, taken at the institution of higher education outside the United States, are equivalent to courses in the college's curriculum. Students can consult with a college counselor on recommended equivalences. Final determination of course equivalency credit will be made by the academic department.
6. If course equivalency is granted, the courses shall be used for all degrees and certificates awarded by the college, except that:
  - a. No course may be used to satisfy the Associate Degree's Reading and Written Expression or Oral Communication requirement, unless the course was taken in a country where English is the native language.
  - b. No course may be used to satisfy the Associate Degree's American Institutions requirement.

Note: In cases where course credit is not granted for the Written Expression, Oral Communication, or American Institutions requirements, elective credit may nevertheless be granted.

7. This evaluation is valid only in the Los Angeles Community College District and may not necessarily meet the requirements of other colleges and universities. Students wishing to transfer should consult with their prospective transfer institution.

### Grade Request Procedures

Students needing copies of their grades can obtain a grade printout from the online [Student Information System](#), or they may obtain a grade printout at the Office of Admissions and Records. Neither form of printout is considered a transcript or a verification of enrollment.

## STUDENT SUCCESS AND SUPPORT PROGRAM

Student Success and Support Program and Assessment Office  
 Student Services Building (SSB), Room 204  
 323-241-5361

[www.lasc.edu/students/Student Success and Support Programs/Student Success and Support Programs\\_process.html](http://www.lasc.edu/students/Student Success and Support Programs/Student Success and Support Programs_process.html)

Christina Gonzalez, Counselor  
 Gabriela Corona, Adjunct Counselor  
 Tara Nishiyama, Adjunct Counselor  
 Shauna Carter, Student Services Assistant

Student Success and Support Program (formerly Matriculation) is a process that enhances student access to Los Angeles Southwest College as well as promotes and sustains the effort of students to be successful in their educational endeavors. The Student Success and Support Program components are designed to provide admission, assessment, orientation, counseling, and follow-up to all enrolled students. The goals of Student Success and Support Program are to ensure that all students complete their college courses, persist to the next academic term, and achieve their educational objectives.

Student Success and Support Program is an agreement between the student and the college. State regulations require that LASC provides you with open access to all courses, programs, and services available at the college, and that we make every possible effort to assist you in planning and attaining your educational goals.



**As part of this agreement, LASC provides:**

- A timely admissions process,
- Information about the campus, Student Success and Support Program process, and policies relating to students,
- Assessment of your basic educational skills and career goals,
- Placement recommendations based on multiple measures,
- Counseling and advisement in the selection of your classes,
- Orientation of college programs, services, and policies,
- Information and referrals for student support services,
- Assistance with progress toward your goals.

**In this partnership, your responsibilities are to:**

- Meet with a counselor to develop a student educational plan,
- Maintain reasonable progress toward your educational goals,
- Attend class and complete assignments,
- Complete courses and maintain progress toward your educational, academic, or career goals

## ACADEMIC INFORMATION AND REGULATIONS

### CONDITIONS OF ENROLLMENT IN LASC CLASSES

Unless specifically exempted by law, every course for which State aid is claimed is fully open to any person who has been admitted to the College and who meets the appropriate academic prerequisites.

#### ADDING CLASSES

Once the term begins, students may no longer add classes through the online Student Information System, but must instead attend the class they wish to add, obtain an approved Add Permit from the instructor, and present the form to the Office of Admissions and Records for processing by the published deadline. Only students who have been admitted to the college (enrolled) and are in approved active status may add classes. All classes must be added by the published Add Deadline in the Schedule of Classes.

Students whose names appear on “Standby Lists” are not officially enrolled and must also obtain an add permit from the instructor and submit it to the Office of Admissions and Records by the deadline to be officially enrolled in the class. Students on Standby Lists do not need to drop Standby classes as they are not officially enrolled in courses listed as “Standby”.

#### ATTENDANCE

Only students who have been admitted to the college and are in an approved active status may attend classes.

Students should attend every meeting of all classes for which they register. To avoid being dropped from class, students should contact the instructor when they are absent for emergency reasons (See Instructor Notification Policy below). Students who are pre-registered in a class and miss the first meeting may lose their right to a place in the class, but the instructor may consider special circumstances. Whenever students are absent more hours than the number of hours the class meets per week, the instructor may, but is not required to, drop them from the class. In addition, the instructor will consider whether there are mitigating circumstances that may justify the absences. If the instructor determines that such circumstances do not exist, the instructor may exclude a student from the class.

Students are responsible for officially dropping a class that they stop attending. See section “Dropping Classes.”

#### INSTRUCTOR NOTIFICATION POLICY

Students should notify the instructor regarding absences by United States mail or by email to the faculty from the district issued student email. Students also may inform the instructor regarding their absences upon return to the class, or by methods detailed by the instructor.



## DROPPING CLASSES

Students wishing to drop one or more classes must do so through the Admissions Office by filing a Drop Card or by using the online Student Information System at [www.lasc.edu](http://www.lasc.edu). Students may no longer drop classes by phone.

Students are responsible for dropping any classes that they do not attend. Instructors may drop you (see Attendance) for failure to attend, but it is your responsibility to ensure that you are officially dropped in order to avoid record of enrollment such as a “W” or a failing grade or fee liability. In order to drop a course to avoid a record of enrollment, you must drop the class before the census date. Drops that occur on or after the census date will result in a “W” grade. Refer to the Academic Calendar in the Schedule of Classes for the specific date to drop without record of enrollment. Dropping with a “W” grade has consequences that may affect your ability to retake the course (see Limitation on Dropping Class).

You may drop classes in person at the Office of Admissions and Records during business hours, or you may drop online using the Student Information System at [www.lasc.edu](http://www.lasc.edu) on the “Register for Classes” link.

Any drops or exclusions that occur between the end of the 2nd week (or 20% of the time the class is scheduled, whichever is less) and the end of the 14th week (or after 75% of the time the class is scheduled, whichever is less) will result in a “W” on the student’s record, which will be included in the determination of progress probation.

A “W” shall not be assigned, or if assigned, shall be removed from a student’s academic record, if a determination is made that the student withdrew from the course due to discriminatory treatment or due to retaliation for alleging discriminatory treatment.

Drops are not permitted beyond the end of the 14th week (or after 75% of the time the class is scheduled, whichever is less). A grade (A, B, C, D, F, I, NP, or P) will be assigned to students who are enrolled past the end of the 14th week even if they stop attending class, except in cases of extenuating circumstances. Check the Schedule of Classes for drop dates.

While it is the responsibility of each student to withdraw officially from a class, it is the responsibility of the faculty to maintain accurate, up-to-date class records. If a student is excluded from a class for non-attendance, and later returns to class and the faculty member permits the return, the instructor must re-instate the student through the Office of Admissions and Records via an Add Permit. The instructor may not elect to allow the returning student to remain active through the rest of the class and then submit an “In-Lieu of Grade Report.” Verification of reinstatement is required for the student to continue in the class.

An instructor may drop/exclude a student from a class if the number of absences exceeds the numbers of hours per week that the class meets. The name of a student who is not attending class should not be left on the class roster as an active student. Students should check their enrollment status throughout the semester to ensure that they have not been erroneously excluded by the instructor.

## CANCELLATION OF CLASSES

The college reserves the right to discontinue any class with insufficient enrollment.

## LIMITATION ON ENROLLING AND WITHDRAWING FROM THE SAME COURSE MORE THAN THREE TIMES

Only three attempts at any one course within the Los Angeles Community College District will be allowed (with some exceptions). A course withdrawal (“W”) or a substandard grade (“D”, “F”, or “NP”) counts as an attempt at a course. After withdrawing from the same course a second time, a student shall receive intervention in the form of a notification that they are only eligible to withdraw from the class one more time. The notice will also urge them to take advantage of college resources to assist them in future academic planning. After the third withdrawal from the same class, a student is blocked from taking that class at any of the LACCD colleges. Under this new regulation, all credit course repeats and withdrawals (except for military withdrawals) in a student’s enrollment record are counted towards the new limits. Students may petition for additional enrollment due to extenuating circumstances, or students may be required to take the course outside of the Los Angeles Community College District. Contact the Office of Admissions and Records for information on exceptions and procedures to request to take a course more than three times. The deadline to submit a petition to enroll in a course after three recorded enrollments is published in the Schedule of Classes each semester. You may not submit a petition for this purpose during winter or summer terms.

## FAMILIES OF COURSES

Active participation courses in physical education, visual arts or performing arts must be clustered into “families,” and students limited to four enrollments per family. Substandard grades and withdrawals count toward the total enrollments. Students attempting to enroll beyond the 4-course limit will be blocked by a message saying they have exceeded the number of courses they can take in that family.

### Course Repeatability

Effective fall 2013, most courses are no longer repeatable in and of themselves. Rather, most course repetition is now tied to the circumstance of the individual student rather than the course itself.

Students who earned a satisfactory grade but want to repeat a non-repeatable course must demonstrate that the course is: (1) required as a condition of employment, (2) educationally mandated under recency requirements [generally not less than 3 years], or (3) due to extenuating circumstances as defined in Title 5, i.e. fire, flood, hospitalization, act of God.

A very limited number of courses will continue to be repeatable. For more information on course repeatability, consult a Counselor.

## AUDITING

Students may be permitted to audit a class under the following conditions:

1. Payment of a fee of \$15 per unit. Fees may not be refunded. Students enrolled in classes to receive credit for 10 or more semester units shall not be charged a fee to audit three or fewer semester units per semester.





2. Students auditing a course shall not be permitted to change their enrollment in that course to receive credit for the course.
3. Priority in class enrollment shall be given to students desiring to take the course for credit.
4. Permission to enroll in a class on an audit basis is at the instructor's discretion.
5. Participation in class activities by student auditors will be solely at the discretion of the instructor, who may provide a written statement of the extent of participation allowed beyond observation.

## CONCURRENT ENROLLMENT

Concurrent enrollment in more than one section of the same course during a semester is not permitted, with the exception of certain Physical Education classes on a limited basis. Concurrent enrollment in courses that are cross-referenced to each other is not permitted (i.e., courses designated "same as" in the District Directory of Educational Programs and Courses). Violation of this regulation will result in exclusion from class and denial of course credit in both courses.

## COURSE REPETITION AND ACTIVITY REPETITION

Active participation courses in physical education, visual arts or performing arts must be clustered into "families", and students limited to four enrollments per family. Substandard grades and withdrawals count toward the total enrollments. Students attempting to enroll beyond the four-course limit will be blocked by a message saying they have exceeded the number of courses they can take in that family.

Most courses are no longer repeatable in and of themselves. Rather, most course repetition is now tied to the circumstances of the individual student rather than the course itself.

Students who earned a satisfactory grade but want to repeat a non-repeatable course must demonstrate that the course is (1) required as a condition of employment, (2) educationally mandated under recency requirements [generally not less than 3 years], or (3) due to extenuating circumstances as defined in Title 5, i.e. fire, flood, hospitalization, act of God.

Excess enrollment will result in an administrative drop. Consult a counselor for the latest restricted activity enrollment list.

## COURSE REPETITION TO IMPROVE SUBSTANDARD GRADES

The Board of Governors adopted regulations that limit apportionment for enrollment in a single credit course to three enrollments, with specific exemptions. Enrollment occurs when a student receives an evaluative (A-F, N, NP, CR, NC) or non-evaluative (W) symbol, pursuant to Title 5, Section 55023. Limits set forth in this new regulation will affect students based on all prior course enrollments. Students will only have three attempts to pass a class within the LACCD. If the student gets a "W" or a grade of "NP" or "F" in a class, that will count as an attempt. Students with three or more such records of enrollment will not be allowed to repeat the course within the Los Angeles Community College District (but can take the course outside of the district). Students may, however, petition to repeat a course a third time within the district (subject to certain conditions) due to extenuating circumstances such as significant lapse of time, military withdrawal, etc.

Exemptions to this policy include courses identified as “repeatable” such as Kinesiology and performing arts in accordance with Title 5, Section 55041, subdivision (c), but do not apply to enrollment in all other credit courses. (See Course Repetition and Activity Repetition section.)

Students may repeat courses in which substandard grades (“D”, “F”, “NC”, or “NP”) were awarded in LACCD. No specific course or categories of courses shall be exempt from course repetition. This policy only applies to courses taken at colleges within the Los Angeles Community College District. Courses completed through the provisions of Board Rule 6704 Credit by Examination may not be used to remove a substandard grade. Other institutions may differ and students planning to transfer to another college should contact the institution regarding their policy. The LACCD Chancellor, in consultation with the District Academic Senate, may adopt regulations to limit course repetition within specific programs.

### FIRST AND SECOND COURSE REPETITION TO IMPROVE SUBSTANDARD GRADES

Upon completion of a repeated course, the highest grade earned will be computed in the cumulative grade point average and the student’s academic record so annotated.

### THIRD COURSE REPETITION TO IMPROVE SUBSTANDARD GRADES

A student may repeat the same course for a third time provided the student has:

1. Received three substandard grades for the same District course,
2. Filed a petition that states the extenuating circumstances are the basis for the petition for the third repeat. “Extenuating circumstances” are verified cases of accidents, illness, military service, or other circumstances beyond the control of the student.
3. Had the petition approved by the College President or designee.

Upon the completion of the third repetition, the grade used in computing the student’s cumulative grade point average shall be the highest grade earned, and the student’s record will be so annotated. The three lower substandard grades will not be used in the computation of the grade point average.

See Nursing Program section of the catalog for additional information regarding Nursing Program academic policy.

### PETITIONING TO REPEAT A COURSE A THIRD TIME

A Petition to Repeat a Course a Third Time accompanied by appropriate documentation must be filed no later than the published deadline for the term during which the student wishes to repeat. The deadline is published each fall and spring semester in the Schedule of Classes.

To be eligible to file a Petition to Repeat a Course a Third Time at least one regular semester (Fall or Spring) must have elapsed since receiving the third substandard grade. A committee will review petitions and students will be notified of the outcome. Petitions to Repeat a Course a Third Time are available in the Office of Admissions and Records and the Counseling Center.

If approved, a student must obtain an Add Permit from the instructor once the semester begins and submit the Add Permit to Admissions and Records for processing.



## COURSE REPETITION: SPECIAL CIRCUMSTANCES

Repetition of courses for which substandard work has not been recorded shall be permitted only upon advance petition of the student and with written permission of the LASC President or designee based on a finding that circumstances exist which justify such repetition. In such repetition under special circumstances, the student's permanent academic record shall be annotated in such a manner that all work remains legible. Grades awarded for repetition under special circumstances shall not be counted in calculating a student's grade point average.

## CREDIT FOR COURSES COMPLETED AT NON-ACCREDITED INSTITUTIONS

Students transferring from non-accredited institutions may, after successful completion of 30 units with a "C" or better grade point average at Los Angeles Southwest College, petition to have previously completed non-accredited courses evaluated for acceptance by LASC. Only 15 units of those credits may be accepted.

The following exceptions may be made to this regulation:

1. **Credit for Graduates of Diploma Schools of Nursing:** The following amount of credit is authorized for graduates of Diploma Schools of Nursing who enter colleges in the Los Angeles Community College District:
  - a. Thirty (30) semester units of credit will be given to graduates of Diploma Schools of Nursing under the following conditions:
    - i. The student presents a valid, current California certificate as a licensed registered nurse to the designated administrative officer; and
    - ii. The student had completed at least 12 units of credit at the College to which application is made.
  - b. The work of graduates of Diploma Schools of Nursing outside California will be recognized if the student has a valid and current California license. Credit will be given even though the license was obtained on the basis of reciprocity with another state rather than by examination.
  - c. Candidates for the Associate of Arts or Associate of Science Degree are exempt from Health Education as a general education requirement. No other general education requirements will be waived,
  - d. Additional courses in Nursing may be taken for credit only upon approval of the Nursing Department,
  - e. The transcript is not to reflect the major field nor should the diploma, where given, indicate Nursing as a major.
2. **Credit for Military Service Training:** Students who are currently serving in or have served in the military service shall have an evaluation of credit earned through military service training schools and/or military occupational specialties, if appropriate.
3. **Credit for Law Enforcement Academy Training:** Credit for basic recruit academy training instructional programs in Administration of Justice or other criminal justice occupations shall be granted as follows:
  - a. Credit will be given for training from institutions that meet the standards of training of the

California Peace Officers Standards and Training Commission.

- b. A single block of credit will be given and identified as academy credit.
- c. One (1) unit of credit may be granted for each 50 hours of training, not to exceed ten (10) semester units or their equivalent.

Credits granted by an institution of higher education for basic recruit academy training, under the above provisions, shall not be identified as equivalent to any required course in the major.

## CREDIT BY EXAMINATION

A College President may designate courses listed in the college catalog wherein any student who satisfies the following requirements may be granted credit by examination:

1. Is currently registered and in good standing, and has a minimum cumulative grade point average of 2.0
2. Has completed 12 units within the Los Angeles Community College District
3. Is not currently enrolled in, or has not completed a more advanced course in this discipline
4. Has never taken the same course for Credit by Examination and passed or not passed the examination

**Limitation on Petitioning for Examination:** The maximum of units for which a student may petition for credit by examination at the college shall be 15 units.

**Maximum Units Allowable:** The maximum number of credit by examination units with a grade of "P" (or "CRX" for courses taken before and up to Fall 2009) that may be applied toward graduation requirements shall be limited to 15 units.

**Acceptance Towards Residence:** Units for which credit is given pursuant to the provisions of this section shall not be counted in determining the 12 semester hours of credit in residence.

**Recording of Grades:** Credit by examination shall be entered on the student's record as "P" or "NP" (or "CRX" or "NCRX" for courses taken before and up to fall 2009) as provided in Board Rule 6702. The student's record shall also be annotated "Credit by Examination" as provided in Board Rule 6704.

**Limitations on Examinations:** A student who does not pass the examination for a course may not repeat the examination.

## ADVANCED PLACEMENT CREDIT

### 1. Course Equivalency

Course equivalency for Advanced Placement exams, for purposes other than meeting General Education and graduation competency requirements for the Associates Degree, shall be determined by the college, using policies developed in consultation with the college's Academic Senate, in accordance with the provisions of LACCD Board Rules, Chapter XVIII, Article I. Course equivalency does not award unit credit. For unit credit policy, see item 3 below.

### 2. Use of Advanced Placement

Use of Advanced Placement exams for meeting General Education Requirements and



graduation competency requirements for the Associate of Arts and Associate of Science Degrees

Advanced Placement (AP) Exams shall be used toward meeting General Education requirements and Graduation Competency for the Associate of Arts and Associate of Science Degrees, as defined in Board Rule Chapter VI, Article II.

Students must receive a passing score (3, 4, or 5) on an AP exam to receive the credit indicated in Appendix A.

### 3. Advanced Placement Unit Credit

For the purpose of granting unit credit toward meeting General Education and graduation competency requirements, LACCD shall follow the guidelines for Advanced Placement credit set by the American Council on Education:

In general, the recommended minimum number of semester hours from ACE corresponds to the status of the corresponding high school AP course:

- Three semester hours are recommended in the case of a half-year course,
- Six semester hours for most full-year courses,
- Eight semester hours for some of the mathematics, sciences, and foreign languages

### 4. CSU GE Breadth and IGETC

The placement of courses in the California State University General Education Breadth (CSU GE Breadth) and the Intersegmental General Education Transfer Curriculum (IGETC) Plans is determined by the University of California and California State University.

## COLLEGE LEVEL EXAMINATION PROGRAM (CLEP) CREDIT

### 1. Course Equivalency

Course equivalency for CLEP (College-Level Examination Program) exams, for purposes other than meeting General Education and Graduation Competency requirements for the Associate Degree, shall be determined by LASC, using policies developed in consultation with the college's Academic Senate, in accordance with the provisions of LACCD Board Rules, Chapter XVIII, Article I. Course equivalency does not award unit credit. For unit credit policy, see item 3 below.

### 2. Use of CLEP exams for meeting General Education requirements and Graduation Competency requirements for the Associate in Arts and Associate in Science Degrees.

CLEP Exams shall be used toward meeting General Education requirements and Graduation Competency for the Associate in Arts and Associate in Science Degrees, as defined in Board Rule Chapter VI, Article II.

Students must receive a passing score (50) on most CLEP exams, except Foreign Language level 2 exams, which require a higher score.

Students who take an Advanced Placement (AP) exam, an International Baccalaureate (IB) exam or College-Level Examination Program (CLEP) exam in the same topic area



will receive credit for only one exam (for example, if a student takes both the CLEP exam in Biology and the AP exam in Biology, they will only be awarded credit for one exam because the topics are duplicative). The college should award credit for the exam that most benefits the student.

### 3. CLEP Unit Credit

For the purpose of granting unit credit toward meeting General Education and Graduation Competency requirements, LACCD shall follow the guidelines for CLEP credit set by the American Council on Education:

- Three semester hours are recommended in the case of a half-year course.
- Six semester hours for most full-year courses.
- Twelve semester hours for Level 2 Foreign Language exams equivalent to four semesters of college-level foreign language coursework.



## LACCD CREDIT FOR ADVANCED PLACEMENT EXAMS

AP SUBJECT AREA	AP SCORE	TOTAL SEMESTER UNITS AWARDED TOWARD ASSOCIATE DEGREE	SEMESTER UNITS APPLIED TOWARD ASSOCIATE DEGREE GE REQUIREMENTS	ASSOCIATE DEGREE GE AREA FULFILLED BOARD RULE: CHAPTER VI: 6201.14	GRADUATION COMPETENCY REQUIREMENT FULFILLED BOARD RULE: CHAPTER VI: 6201.12	TITLE 5 AMERICAN INSTITUTIONS REQUIREMENT FULFILLED BOARD RULE: CHAPTER VI: 6201.14	IGETC APPLICABILITY SOURCE: IGETC STANDARDS V 1.6	CSU GE BREADTH APPLICABILITY SOURCE: CSU CODED MEMO A/ AA-2015-19
Art Studio Drawing	3, 4, 5	3	3	Section C: Humanities			N/A	N/A
Art Studio 2D Design	3, 4, 5	3	3	Section C: Humanities			N/A	N/A
Art Studio 3D Design	3, 4, 5	3	3	Section C: Humanities			N/A	N/A
Art History	3, 4, 5	6	3	Section C: Humanities			3A or 3B 3 semester units/ 4 quarter units	C1 or C2 3 semester units
Biology	3, 4, 5	6	3	Section A: Natural Science			5B and 5C 4 semester units/ 5 quarter units	B2 and B3 4 semester units
Chemistry	3, 4, 5	6	3	Section A: Natural Science			5A and 5C 4 semester units/ 5 quarter units	B1 and B3 4 semester units
Chinese Language & Culture	3, 4, 5	6	3	Section C: Humanities			3B and 6A 3 semester units/ 4 quarter units	C2 3 semester units
Computer Science Exam A	3, 4, 5	3	3	Section D: Language & Rationality: Area 2. Communication and Analytical Thinking			N/A	N/A
Computer Science Exam AB	3, 4, 5	6	3	Section D: Language & Rationality: Area 2. Communication and Analytical Thinking			N/A	N/A
Economics - Macroeconomics	3, 4, 5	3	3	Section B2: Social and Behavioral Sciences			4 3 semester units/ 4 quarter units	D2 3 semester units
Economics - Microeconomics	3, 4, 5	3	3	Section B2: Social and Behavioral Sciences			4 3 semester units/ 4 quarter units	D2 3 semester units
English Language & Composition	3, 4, 5	6	3	Section D: Language & Rationality: Area 1. English Composition	Reading and Written Expression Competency Satisfied		1A 3 semester units/ 4 quarter units	A2 3 semester units
English Literature & Composition	3, 4, 5	6	3	Section D: Language & Rationality: Area 1. English Composition	Reading and Written Expression Competency Satisfied		1A or 3B 3 semester units/ 4 quarter units	A2 and C2 6 semester units
Environmental Science	3, 4, 5	4	3	Section A: Natural Science			5A and 5C 3 semester units/ 4 quarter units	B1 and B3 4 semester units
French Language & Culture	3, 4, 5	6	3	Section C: Humanities			3B and 6A 3 semester units/ 4 quarter units	C2 3 semester units
French Literature & Culture	3, 4, 5	6	3	Section C: Humanities			3B and 6A 3 semester units/ 4 quarter units	C2 3 semester units (removal fall 09)
German Language & Culture	3, 4, 5	6	3	Section C: Humanities			3B and 6A 3 semester units/ 4 quarter units	C2 3 semester units
Government & Politics: U.S.	3, 4, 5	3	3	Section B1: American Institutions		American Institutions Satisfied	4 and US-2 3 semester units/ 4 quarter units	D8+US-2 3 semester units
Government & Politics: Comparative	3, 4, 5	3	3	Section B2: Social and Behavioral Sciences			4 3 semester units/ 4 quarter units	D8 3 semester units
History: European	3, 4, 5	6	6	Section B2: Social and Behavioral Sciences AND Section C: Humanities			3B or 4 3 semester units/ 4 quarter units	C2 or D6 3 semester units
History: U.S.	3, 4, 5	6	3	Section B1: American Institutions		American Institutions Satisfied	3B or 4 and US-1 3 semester units/ 4 quarter units	C2 or D6 + US-1 3 semester units



AP SUBJECT AREA	AP SCORE	TOTAL SEMESTER UNITS AWARDED TOWARD ASSOCIATE DEGREE	SEMESTER UNITS APPLIED TOWARD ASSOCIATE DEGREE GE REQUIREMENTS	ASSOCIATE DEGREE GE AREA FULFILLED BOARD RULE: CHAPTER VI: 6201.14	GRADUATION COMPETENCY REQUIREMENT FULFILLED BOARD RULE: CHAPTER VI: 6201.12	TITLE 5 AMERICAN INSTITUTIONS REQUIREMENT FULFILLED BOARD RULE: CHAPTER VI: 6201.14	IGETC APPLICABILITY SOURCE: IGETC STANDARDS V 1.6	CSU GE BREADTH APPLICABILITY SOURCE: CSU CODED MEMO A/ AA-2015-19
History: World	3, 4, 5	6	3	Section B2: Social and Behavioral Sciences			3B or 4 3 semester units/ 4 quarter units	C2 or D6 3 semester units
Human Geography	3, 4, 5	3	3	Section B2: Social and Behavioral Sciences			4 3 semester units/ 4 quarter units	D5 3 semester units
Italian Language & Culture	3, 4, 5	6	3	Section C: Humanities			3B and 6A 3 semester units/ 4 quarter units	C2 3 semester units
Japanese Language & Culture	3, 4, 5	6	3	Section C: Humanities			3B and 6A 3 semester units/ 4 quarter units	C2 3 semester units
Latin Literature	3, 4, 5	6	3	Section C: Humanities			3B and 6A 3 semester units/ 4 quarter units	C2 3 semester units (removal fall 09)
Latin: Vergil	3, 4, 5	3	3	Section C: Humanities			3B and 6A 3 semester units/ 4 quarter units	C2 3 semester units (removal fall 12)
Mathematics – Calculus AB	3, 4, 5	3	3	Section D: Language & Rationality: Area 2. Communication and Analytical Thinking	Mathematics Competency Satisfied		2A 3 semester units/ 4 quarter units	B4 3 semester units
Mathematics – Calculus BC	3, 4, 5	6	3	Section D: Language & Rationality: Area 2. Communication and Analytical Thinking	Mathematics Competency Satisfied		2A 3 semester units/ 4 quarter units	B4 3 semester units
Mathematics – Calculus BC/AB Subscore	3, 4, 5	3	3	Section D: Language & Rationality: Area 2. Communication and Analytical Thinking	Mathematics Competency Satisfied		2A 3 semester units/ 4 quarter units	B4 3 semester units
Music Theory	3, 4, 5	6	3	Section C: Humanities			N/A	C1 3 semester units (removal fall 09)
Physics 1	3,4,5	4	3	Section A: Natural Science			5A and 5C 4 semester units/ 5 quarter units	B1 and B3 4 semester units
Physics 2	3,4,5	4	3	Section A: Natural Science			5A and 5C 4 semester units/ 5 quarter units	B1 and B3 4 semester units
Physics B	3, 4, 5	6	3	Section A: Natural Science			5A and 5C 4 semester units/ 5 quarter units	B1 and B3 4 semester units (removal fall 13)
Physics C Mechanics	3, 4, 5	4	3	Section A: Natural Science			5A and 5C 3 semester units/ 4 quarter units	B1 and B3 4 semester units
Physics C Electricity & Magnetism	3, 4, 5	4	3	Section A: Natural Science			5A and 5C 3 semester units/ 4 quarter units	B1 and B3 4 semester units
Psychology	3, 4, 5	3	3	Section B2: Social and Behavioral Sciences			4 3 semester units/ 4 quarter units	D9 3 semester units
Spanish Language & Culture	3, 4, 5	6	3	Section C: Humanities			3B and 6A 3 semester units/ 4 quarter units	C2 3 semester units
Spanish Literature & Culture	3, 4, 5	6	3	Section C: Humanities			3B and 6A 3 semester units/ 4 quarter units	C2 3 semester units
Statistics	3, 4, 5	3	3	Section D: Language & Rationality: Area 2. Communication and Analytical Thinking	Mathematics Competency Satisfied		2A 3 semester units/ 4 quarter units	B4 3 semester units





## LACCD CREDIT FOR COLLEGE-LEVEL EXAMINATION PROGRAM (CLEP) EXAMS

CLEP EXAM	ACE RECOMMENDED SCORE	TOTAL SEMESTER UNITS AWARDED TOWARD ASSOCIATE DEGREE	SEMESTER UNITS APPLIED TOWARD ASSOCIATE DEGREE REQUIREMENTS	ASSOCIATE DEGREE SECTION FULFILLED BOARD RULE: CHAPTER VI: 6201.14	GRADUATION COMPETENCY REQUIREMENT FULFILLED BOARD RULE: CHAPTER VI: 6201.12	TITLE 5 AMERICAN INSTITUTIONS REQUIREMENT FULFILLED BOARD RULE: CHAPTER VI: 6201.14
<b>BUSINESS EXAMS</b>						
Financial Accounting	50	3	N/A			
Information Systems and Computer Applications	50	3	3	Section D2: Communication and Analytical Thinking		
Introductory Business Law	50	3	N/A			
Principles of Management	50	3	N/A			
Principles of Marketing	50	3	N/A			
<b>COMPOSITION AND LITERATURE</b>						
American Literature	50	3	3	Section C: Humanities		
Analyzing and Interpreting Literature	50	3	3	Section C: Humanities		
College Composition replaces English Composition w/essay effective 07/01/10	50	6	3	Section D: Language & Rationality: Area 1, English Composition		
College Composition Modular Replaces English Composition and Freshman College Composition exams effective 07/01/10	50	3	3	Section D: Language & Rationality: Area 1, English Composition		
English Literature	50	3	3	Section C: Humanities		
Humanities	50	3	3	Section C: Humanities		
<b>FOREIGN LANGUAGES</b>						
French Language, Level 1	50	6	3	Section C: Humanities		
French Language, Level 2	59	9	3	Section C: Humanities		
German Language, Level 1	50	6	3	Section C: Humanities		
German Language, Level 2	60	9	3	Section C: Humanities		
Spanish Language, Level 1	50	6	3	Section C: Humanities		
Spanish Language, Level 2	63	9	3	Section C: Humanities		
Level 1 - Equivalent to the first two semesters (or 6 semesters hours) of college-level foreign language course work						
Level 2 - Equivalent to the first four semesters (or 12 semester hours) of college-level foreign language course work						
<b>HISTORY AND SOCIAL SCIENCES</b>						
American Government	50	3	3	Section B1: American Institutions		American Institutions Satisfied
History of the United States I: Early Colonization to 1877	50	3	3	Section B1: American Institutions		American Institutions Satisfied
History of the United States II: 1865 to present	50	3	3	Section B1: American Institutions		American Institutions Satisfied
Human Growth and Development	50	3	3	Section B2: Social and Behavioral Sciences		



CLEP EXAM	ACE RECOMMENDED SCORE	TOTAL SEMESTER UNITS AWARDED TOWARD ASSOCIATE DEGREE <sup>1</sup>	SEMESTER UNITS APPLIED TOWARD ASSOCIATE DEGREE REQUIREMENTS	ASSOCIATE DEGREE SECTION FULFILLED BOARD RULE: CHAPTER VI: 6201.14	GRADUATION COMPETENCY REQUIREMENT FULFILLED BOARD RULE: CHAPTER VI: 6201.12	TITLE 5 AMERICAN INSTITUTIONS REQUIREMENT FULFILLED BOARD RULE: CHAPTER VI: 6201.14
Introduction to Educational Psychology	50	3	3	Section B2: Social and Behavioral Sciences		
Introductory Psychology	50	3	3	Section B2: Social and Behavioral Sciences		
Introductory Sociology	50	3	3	Section B2: Social and Behavioral Sciences		
Principles of Macroeconomics	50	3	3	Section B2: Social and Behavioral Sciences		
Principles of Microeconomics	50	3	3	Section B2: Social and Behavioral Sciences		
Social Sciences and History	50	6	3	Section B2: Social and Behavioral Sciences		
Western Civilization I: Ancient Near East to 1648	50	3	3	Section B2: Social and Behavioral Sciences		
Western Civilization I: 1648 to Present	50	3	3	Section B2: Social and Behavioral Sciences		
<b>SCIENCE AND MATHEMATICS</b>						
Biology	50	6	3	Section A: Natural Sciences		
Calculus	50	4	3	Section D2: Communication and Analytical Thinking	Mathematics Competency Satisfied	
Chemistry	50	6	3	Section A: Natural Sciences		
College Algebra	50	3	3	Section D2: Communication and Analytical Thinking	Mathematics Competency Satisfied	
College Mathematics	50	6	3	Section D2: Communication and Analytical Thinking	Mathematics Competency Satisfied	
Precalculus	50	3	3	Section D2: Communication and Analytical Thinking	Mathematics Competency Satisfied	
Natural Sciences	50	6	3	Section A: Natural Sciences		

<sup>1</sup>The scores and credit hours that appear in this table are the credit-granting scores and semester hours recommended by the American Council on Education (ACE). The scores listed above are equivalent to a grade of "C" in the corresponding course. The credit in this table is applicable for local Associate Degrees only.



LACCD CREDIT FOR INTERNATIONAL BACCALAUREATE (IB) EXAMS

IB SUBJECT AREA	MINIMUM PASSING SCORE A.A./A.S. CSU GE IGETC	TOTAL SEMESTER UNITS AWARDED TOWARD ASSOCIATE DEGREE	SEMESTER UNITS APPLIED TOWARD ASSOCIATE DEGREE GE REQUIREMENTS	ASSOCIATE DEGREE GE AREA FULFILLED BOARD RULE: CHAPTER VI: 6201.14	GRADUATION COMPETENCY REQUIREMENT FULFILLED BOARD RULE: CHAPTER VI: 6201.12	TITLE 5 AMERICAN INSTITUTIONS REQUIREMENT FULFILLED BOARD RULE: CHAPTER VI: 6201.14	IGETC APPLICABILITY SOURCE: IGETC STANDARDS V 1.3	CSU GE BREADTH APPLICABILITY SOURCE: CSU CODED MEMO AA -2010-09
IB Biology HL	5 (ALL)	6	3	Section A: Natural Science			5B 3 semester units/ 4 quarter units	B2 3 semester units
IB Chemistry HL	5 (ALL)	6	3	Section A: Natural Science			5A 3 semester units/ 4 quarter units	B1 3 semester units
IB Economics HL	5 (ALL)	6	3	Section B2: Social and Behavioral Sciences			4B 3 semester units/ 4 quarter units	D2 3 semester units
IB Geography HL	5 (ALL)	6	3	Section B2: Social and Behavioral Sciences			4E 3 semester units/ 4 quarter units	5D 3 semester units
IB History (any region) HL	5 (ALL)	6	3	Section B2: Social and Behavioral Sciences			3B or 4F 3 semester units/ 4 quarter units	C2 or D6 3 semester units
IB Language A1 (ENGLISH) HL	4 (A.A./A.S.)	6	3	Section D: Language & Rationality: Area 1 English Communication	Reading and Written Expression Competency Satisfied		Refer below to IB Language A1 (any language) HL for IGETC Area applicability	Refer below to IB Language A1 (any language) HL for CSU GE Area applicability
IB Language A2 (ENGLISH) HL	4 (A.A./A.S.)	6	3	Section D: Language & Rationality: Area 1 English Communication	Reading and Written Expression Competency Satisfied		Refer below to IB Language A2 (any language) HL for IGETC Area applicability	Refer below to IB Language A2 (any language) HL for CSU GE Area applicability
IB Language A1 (any language, except English) HL	4 (A.A./A.S.) 5 (IGETC)	6	3	Section C: Humanities			3B and 6A 3 semester units/ 4 quarter units	N/A
IB Language A2 (any language, except English) HL	4 (A.A./A.S.) 5 (IGETC)	6	3	Section C: Humanities			3B and 6A 3 semester units/ 4 quarter units	N/A
IB Language A1 (any language) HL	4 (A.A./A.S.) 4 (CSU GE) 5 (IGETC)	6	3	Section C: Humanities			3B 3 semester units/ 4 quarter units	C2 3 semester units
IB Language A2 (any language) HL	4 (A.A./A.S.) 4 (CSU GE) 5 (IGETC)	6	3	Section C: Humanities			3B 3 semester units/ 4 quarter units	C2 3 semester units
IB Language B* (any language) HL	4 (A.A./A.S.) 4 (CSU GE) 5 (IGETC)	6	3	Section C: Humanities			6A Meets proficiency reg.	N/A
IB Mathematics HL	4 (A.A./A.S.) 4 (CSU GE) 5 (IGETC)	6	3	Section D: Language & Rationality: Area 2 Communication and Analytical Thinking	Mathematics Competency Satisfied		2A 3 semester units/ 4 quarter units	B4 3 semester units
IB Physics HL	5 (ALL)	6	3	Section A: Natural Science			5A (without lab) 3 semester units/ 4 quarter units	B1 3 semester units
IB Psychology HL	5 (ALL)	3	3	Section B2: Social and Behavioral Sciences			4I 3 semester units/ 4 quarter units	D9 3 semester units
IB Theater HL	4 (A.A./A.S.) 4 (CSU GE) 5 (IGETC)	6	3	Section C: Humanities			3A 3 semester units/ 4 quarter units	C1 3 semester units



## INTERNATIONAL BACCALAUREATE (IB) CREDIT

The International Baccalaureate (IB) Diploma Program is a challenging two-year curriculum, primarily aimed at students from 16 to 19 years old. The IB Diploma Program is a comprehensive pre-university course of study, leading to examinations that demand the best from motivated students and teachers. It is widely recognized for its high academic standards.

- The two-year curriculum is rigorous and intellectually coherent, encouraging critical thinking through the study of a wide range of subjects in the traditional academic disciplines while encouraging an international perspective.
- Beyond completing college-level courses and examinations, Diploma Program students are also required to engage in community service, individual research, and an inquiry into the nature of knowledge.
- The two-year course of study leads to final examinations in six subject areas.

### THE IB GOVERNANCE IS COMPOSED OF:

- An IB Board of Governors
- Six committees (access and advancement, audit, compensation, education, finance and governance)

<sup>1</sup>The IB curriculum offers language at various levels for native and non-native speakers.

Language B courses are offered at the intermediate level for non-natives. Language A1 and A2 are advanced courses in literature for native and non-native speakers, respectively.

### REQUIREMENTS

#### 1. Course Equivalency

Course equivalency for IB (International Baccalaureate) exams, for purposes other than meeting General Education and graduation competency requirements for the Associate Degree, shall be determined by the college, using policies developed in consultation with the college's Academic Senate, in accordance with the provisions of LACCD Board Rules, Chapter XVIII, Article I. Course equivalency does not award unit credit. For unit credit policy, see item 3 below.

#### 2. Use of IB Exams for meeting General Education Requirements and Graduation Competency requirements for the Associate in Arts and Associate in Science Degrees

IB Exams shall be used toward meeting General Education requirements and Graduation Competency for the Associate in Arts and Associate in Science Degrees, as defined in Board Rule Chapter VI, Article II. Students must receive a minimum score of 4 on most IB exams; other exams may require a score of 5. Credit will only be given for Higher Level (HL) exams. No credit is given for Standard Level (SL) exams.

Students who take an Advanced Placement (AP) exam, an International Baccalaureate (IB) exam or College-Level Examination (CLEP) exam in the same topic area will receive credit for only one exam. For example, if a student takes both the AP exam in Biology and the IB Biology HL exam, they will only receive credit for one exam because the topics are duplicative. The college should award credit for the exam that most benefits the student.

#### 3. IB Unit Credit



For the purpose of granting unit credit towards meeting General Education and graduation competency requirements, the LACCD shall follow the guidelines for IB credit set by the International Baccalaureate Organization: Students can receive a score of one (poor or elementary) to seven (excellent) for each subject studied. Universities and colleges typically expect individual HL Subject scores to be a minimum of four (satisfactory) or sometimes five (good) for credit consideration.

#### 4. CSU GE Breadth and IGETC

The placement of courses in the California State University General Education Breadth (CSU GE Breadth) and the Intersegmental General Education Transfer Curriculum (IGETC) Plans is determined by the University of California and California State University systems respectively; therefore it is not necessary for the college to grant course equivalency for this to occur. Appendix A indicates how IB exams are used to meet these requirements.

#### 5. Annotation of IB GE/Elective Credit on LACCD Transcripts

IB credit should be annotated on LACCD transcripts using the following format: IB Exam name: Score received; A.A/A.S. GE Area met; units awarded (if applicable); A.A/A.S. electives; units awarded (if applicable); competency met (if applicable). See Page 61 for more information.

## COURSE PREREQUISITES

### Prerequisites, Corequisites and Recommended Courses

When the words “Prerequisite,” “Corequisite,” or “Recommended” appear in the Schedule of Classes or the College Catalog, it is important to understand the definitions of these terms.

**PREREQUISITE** means a condition of enrollment that a student is required to meet in order to demonstrate current readiness for enrollment in a course or educational program. A prerequisite represents a set of skills or a body of knowledge that a student must possess prior to enrollment and without which the student is highly unlikely to succeed in the course or program. Students will not be permitted to enroll in such courses and programs without the appropriate prerequisite.

**COREQUISITE** means a condition of enrollment consisting of a course that a student is required to simultaneously take in order to enroll in another course. A corequisite represents a set of skills or a body of knowledge that a student must acquire through concurrent enrollment in another course and without which the student is highly unlikely to succeed. Students must concurrently enroll in corequisite courses.

**RECOMMENDED** means a condition of enrollment that a student is advised, but not required, to meet before or in conjunction with enrollment in a course or educational program. Recommended preparation represents a set of skills or a body of knowledge with which a student will achieve a greater depth or breadth of knowledge of course material but without which the student is still likely to succeed in the course or program.

## PREREQUISITE CHALLENGE PROCESS

LASC has established procedures by which any student who does not meet a prerequisite or

corequisite requirement or who is not permitted to enroll due to a limitation on enrollment, but who provides satisfactory evidence, may seek entry into the class according to the challenge process. The Prerequisite Challenge Form can be obtained from the Counseling Office (or SSSP office). All requests should be turned in no earlier than two weeks before the start of the school term and no later than five days after the first class meeting.

### Specific ways a student may challenge a prerequisite for a course:

1. Challenging the prerequisite on the grounds that it has not been made reasonably available,
2. Challenging the prerequisite on the grounds that it is not valid because it is not necessary for success in the course for which it is required,
3. Challenging the prerequisite because it is discriminatory or applied in a discriminatory manner, or,
4. Challenging the prerequisite based on student knowledge or ability to succeed in the course despite not meeting the prerequisite.

## CREDIT FOR PREREQUISITES

Students may not concurrently enroll in and receive credit for an advanced course and its prerequisite(s). Students may not enroll in and receive credit for the prerequisite(s) to an advanced course if they have previously completed the advanced course. Violation of this regulation will result in exclusion from class and denial of course credit.

To meet content competency, complete all pre-requisites with a grade of “C” or better.

## GRADING SYMBOLS AND DEFINITIONS

Only the symbols in the grading scale given in this section shall be used to grade all courses offered in fulfillment of the requirements for an associate or baccalaureate degree, a certificate, diploma, or license.

Grades shall be averaged on the basis of the point equivalences to determine a student’s grade-point average, using the following evaluative symbols:

Grade	Points
A Excellent	4
B Good	3
C Satisfactory	2
D Passing	1
F Failing	0

**P Pass** (formerly Credit): At least satisfactory. Units awarded are not counted in GPA.

**NP No Pass** (formerly No Credit): Less than satisfactory. Units are not counted in GPA.

**RD Report Delayed:** Grade filed late or not yet filed by instructor.

P and NP grades may be given only in courses authorized by the District Pass/No Pass Option and Credit by Examination Policies.



See below for non-evaluative symbols may be entered on a student's record.

### **I – Incomplete**

Once the student has informed the instructor of record of incomplete academic work for unforeseeable, emergency, and justifiable reason at the end of the term, it may result in an “I” symbol being entered in the student's record. The condition for removal of the Incomplete shall be stated by the instructor on the Incomplete Grade form.

This record shall contain the detailed condition(s) for the removal of the incomplete and the grade to be assigned in lieu of the incomplete. This record shall be given to the student, with a copy on file in the Office of Admissions and Records until the Incomplete work is to be made up or within the time limit of one year.

The Incomplete shall not be used in calculating units attempted or for grade points. The Incomplete may be made up no later than one year following the end of the term in which it was assigned. Note: Courses in which the student has received an Incomplete (“I”) may not be repeated unless the “I” is removed and has been replaced by a grade of “D” or “F”. This does not apply to courses which are repeatable for additional credit.

### **IP – In Progress**

The “IP” symbol shall be used only in those courses which extend beyond the normal end of an academic term. “IP” indicates that work is “in progress” but that assignment of a substantive grade must await its completion. The “IP” symbol shall remain on the student's permanent record in order to satisfy enrollment documentation. The appropriate evaluative grade and unit credit shall be assigned and appear on the student's record for the term in which the required work of the course is completed. The “IP” shall not be used in calculating grade-point averages. If a student enrolled in an “open-entry, open-exit” course is assigned “IP” at the end of an attendance period and does not complete the course during the subsequent attendance period, the appropriate faculty will assign an evaluative symbol (grade) as specified above to be recorded on the student's permanent record for the course.

### **MW – Military Withdrawal**

“Military withdrawal” occurs when a student who is a member of an active or reserve United States military service receives orders compelling a withdrawal from courses. Upon verification of such orders, a “MW” may be assigned at any time after 30% of the time the class is scheduled to meet. No notation (“W” or other) shall be made on the records of a student who withdraws during the first 30% of the time the class is scheduled. Enrollment fees will be refunded with military withdrawals. Military withdrawals shall not be counted in progress probation and dismissal calculations, nor are they counted in the three attempts to take a course.

### **RD – Report Delayed**

The “RD” symbol may be assigned by the registrar only. It is to be used when there is a delay in reporting the grade of a student due to circumstances beyond the control of the student. It is a temporary notation to be replaced by a permanent symbol as soon as possible. RD is not used in calculating grade-point averages.

## W – Withdrawal

Withdrawal from a class or classes shall be authorized up through 75% of the time the class is scheduled to meet.

No notation (“W” or other) shall be made on the record of a student who withdraws during the first 20% of the time the class is scheduled to meet.

Students can withdraw from classes between the end of the second week (or 20% of the time the class is scheduled to meet, whichever is less) and up through 75% of the time the class is scheduled to meet. A student who remains in class beyond 75% of the time the class is scheduled shall be given a grade other than a “W,” except in cases of extenuating circumstances.

After 75% of the time the class is scheduled, the student may withdraw from class by a petition demonstrating extenuating circumstances and after consultation with the appropriate faculty. Students should obtain a petition in the Office of Admissions and Records.

Extenuating circumstances are verified cases of accidents, illness, or other circumstances beyond the control of the student. Withdrawal after the end of 75% of the time the class is scheduled, which has been authorized as extenuating circumstances, shall be recorded as “W.”

## PASS/NO PASS OPTION

These are designated courses in the College Catalog wherein all students are evaluated on a “Pass/No Pass” (formerly “Credit/No Credit”) basis or wherein each student may elect on registration by no later than the end of the first 30% of the term, whether the basis of evaluation is to be Pass/No Pass or a letter grade. These courses will be noted in the College Catalog as being eligible for the Pass/No Pass option.

1. **Usage for Single Performance Standard:** The Pass/No Pass grading system shall be used in any course in which there is a single satisfactory standard of performance for which unit credit is assigned. A grade of Pass (P) shall be assigned for meeting that standard, and a grade of No Pass (NP) shall be assigned for failure to do so.
2. **Acceptance of Credits:** All units earned on a Pass/No Pass basis in accredited California institutions of higher education or equivalent out-of-state institutions shall be counted in satisfaction of community college curriculum requirements.
3. **Recording of Grade:** A student who is approved to be evaluated on the Pass/No Pass basis shall receive both course credit and unit credit upon satisfactory completion of the course. Satisfactory completion for credit is equivalent to the grade of “C” or better. A student who does not perform satisfactorily will be assigned a No Pass (NP) grade.
4. **Grade Point Calculation:** Units earned on a Pass/No Pass basis shall not be used to calculate grade-point-averages. However, units attempted for which No Pass (NP) is recorded shall be considered in probationary and dismissal procedures.
5. **Standards of Evaluation:** The student who is enrolled in a course on a Pass/No Pass basis will be held responsible for all assignments and examination requirements in the course and must meet the standards of evaluation, which are identical for all students.





6. **Conversion to Letter Grade:** A student who has received credit for a course taken on a Pass/No Pass basis may not convert this credit to a letter grade.
7. **Course Repetition:** A student who has received a grade of No Pass (NP) may repeat the course by meeting the requirements set forth by the District Course Repetition to Improve Substandard Grades Policy.

## CAMPUS PROCEDURE FOR USING THE PASS/NO PASS OPTION

A student wishing to take a course on a Pass/No Pass basis will go to the Office of Admissions and Records during the sixth week of a semester (the second week of a five-week summer and winter session or the fourth week of a twelve-week summer session) and record his/her choice by completing the proper form. A student who elects to be evaluated on a Pass/No Pass basis does not have the option of reversing this decision. In certain courses listed below and marked by an (\*), all students are evaluated on a Pass/No Pass basis. In the other courses a student may elect whether to be graded with the conventional letter grade (A-F) or on a Pass/No Pass basis. A student electing to be evaluated on the Pass/No Pass basis will receive both course credit and unit credit upon satisfactory completion of the course. A student who fails to perform satisfactorily will be assigned a No Pass grade. In computing a student's grade point average, grades of Pass or No Pass are omitted.

A student is allowed to enroll in only one course per semester on a Pass/No Pass basis; a maximum of 15 units may be applied toward the two-year degree on this basis.

Courses taken for Pass/No Pass do not meet the prerequisites for the next higher courses unless special approval is secured from the appropriate department chair. The general practice at most four-year colleges is not to accept Pass/No Pass grades for courses required in the major or preparation for the major.

List of available courses with Pass/No Pass:

- Administration of Justice - All courses
- Art - 201, 202, 300, 307, 501
- Business - All courses
- Computer Applications and Office Technology (CAOT)
- Computer Science - All courses
- Counseling - 006, 017
- Developmental Communications - 022, 023, 026
- Economics - All courses
- Electronics - All courses
- Engineering, General - 101
- English - 102
- Foreign Languages - French 001, 002, 003, 004; Spanish 001, 002, 003, 004
- Geology 001
- History - All courses



- Family & Consumer Studies - All courses
- Humanities - All courses
- Journalism 101
- Library Science - 101
- Mathematics - 105, 115, 125, 230, 235, 236, 240, 265, 266, 267, 270
- Nursing 517
- Philosophy - 007, 008
- Political Science - All courses
- Psychology - 003, 030, 043
- Sociology - All courses

## FINAL EXAMINATIONS

Final examinations are held in all subjects, according to the Schedule of Classes. No student will be excused from final examinations. Should any circumstance develop requiring a special examination at a time earlier or later than the scheduled time, special authorization must be secured from the Office of Academic Affairs.

## GRADES AND GRADE CHANGES

The instructor of the course shall determine the grade to be awarded to each student in accordance with the Los Angeles Community College Board Rule 6705 and Title 5, C.C.R., Section 55760. The determination of the student's grade by the instructor is final in the absence of mistake, fraud, bad faith, or incompetence. Any removal or change of a grade in a student's record shall be done only upon authorization by the instructor of the course.

When an instructor is not available for review, the existing grade shall remain unless the student can show evidence that an error was made in the calculation of grade.

A grade may not be challenged by a student more than one calendar year from the end of the term in which the course was taken. If there is proof of unusual circumstances such as an unforeseen long illness of the student or if the student is called to military duty, a grade may be challenged up to two calendar years from the end term in which the course was taken.

If a student wishes to challenge a grade, the following steps should be followed:

1. Consult the Instructor for resolution,
2. Confer with the Department Chair as second level of authority if issue is not resolved,
3. Make an appointment with the Dean of the relevant academic department if there is no resolution at Levels 1 or 2,
4. The Dean of the relevant academic department may refer the student to the Dean of Student Services or to the Executive Vice President if there is no resolution at Level 3,
5. Further referral may be to the College President or to the LACCD Office.



## ACADEMIC RENEWAL

Students may submit a petition to the Office of Admissions and Records to have their academic records reviewed for academic renewal action of substandard academic performance under the following conditions:

1. Students must have achieved a grade-point average of 2.5 in their last 15 semester units, or 2.0 in their last 30 semester units completed at any accredited college or university, and,
2. At least one (1) calendar year must have elapsed from the time the coursework to be removed was completed.

If the above conditions are met, academic renewal shall be granted, consisting of:

1. Eliminating from consideration in the cumulative grade-point-average up to 30 semester units of course work within LACCD,
2. Annotating the student academic record indicating where courses have been removed by academic renewal action.

Academic renewal actions are irreversible.

## ACADEMIC STANDARDS

### ACADEMIC REGULATIONS – DISTRICT POLICIES

#### **Good Standing**

In determining a student's eligibility to acquire or remain in good standing and attendance, both quality of performance and progress toward completion of objectives are considered. A student who completes 12 or more semester units and earns a 2.0 GPA on a 4 point grading scale and who completes 50 percent or more of all enrolled units merits a good standing relationship with the college. Students in good standing are limited to 19 units per semester. In exceptional cases, a student may initiate a petition with the Office of Admissions and Records to exceed the 19-unit limit.

#### **Academic Standards and Credit Policies**

A student shall be subject to dismissal and subsequently be dismissed under the conditions set forth within this section. Dismissal shall be determined based on student coursework dating from Fall 1981, course work completed prior to Fall of 1981 is excluded from dismissal calculations.

## UNITS OF WORK/STUDY LOAD

#### **Study Load Limitations**

Maximum and minimum unit requirements may apply, as follows:

- Nineteen (19) is the maximum number of units a student may enroll in during the fall and spring semesters
- Nine (9) units is the maximum number of units a student may enroll in for the winter session

- Nine (9) is the maximum for all summer sessions district-wide

The normal class load for students in the fall or spring semester is 12 to 19 units per semester for full-time students. A college program of 15 units is equal to at least a 40-hour work week for most students.

Those students who will be employed while attending college should consider reducing their programs accordingly. It is suggested that those students who are employed full-time should enroll in no more than one or two classes or nine units maximum.

Students may petition to take 20 or more units if they meet the following criteria:

1. Have established a grade point average of 2.7 or higher in the Los Angeles Community College District, or,
2. Provide evidence of a 2.7 or higher grade point average through a transcript from an accredited institution.

### **Enforcement of 30-Unit Limit on Basic Skills Courses**

Title 5, California Code of Regulations, limits a student from taking more than 30 units of “remedial” course work, which is defined as “non-degree applicable basic skills courses.” The LACCD’s registration system will prevent students who have exceeded this limit from enrolling in additional basic skills courses. However, a student who has reached this limit but enrolls in a credit or non-credit English as a Second Language (ESL) course will be allowed to also enroll in additional basic skills courses. Students with a learning disability may request an exemption through the Disabled Students Programs & Services Office (DSP&S). This limitation does not apply to enrollment in non-credit basic skills courses.

A student who is subject to the 30-Unit Limit on Basic Skills courses may petition for an exemption by contacting the Counseling Department.

The following courses are considered Basic Skills courses for purposes of this unit limitation:

- English 021, 094
- Learning Foundations 045, 055
- Math 105, 110, 112

## ACADEMIC HONORS

### **Dean’s Honor List**

Each semester, fall and spring, an Honor List is composed of students who have satisfactorily completed 12 or more units in a given semester with a 3.5 grade point average or who have completed six to 11.5 units in a semester with a 3.5 grade point average and have completed a cumulative total of 12 or more units with a 3.5 grade-point average in all work attempted.

The units referred to above must be transferable units and must not be units earned for repeated classes. In recognition of this scholastic accomplishment, each student is honored and awarded a certificate. The certificate issued for the first and second semester is titled the Dean’s Honor List.

## President's Honor Award

Students who have met the requirements for the Dean's Honor List for three consecutive semesters qualify for the President's Honor Award.

## Graduation Honors

Some graduates will be recognized at the annual commencement ceremony for outstanding scholastic achievement. Outstanding academic achievement is designated by the Latin phrases Summa Cum Laude (with greatest praise), Magna Cum Laude (with great praise), and Cum Laude (with praise) for the cumulative grade point average in all college courses attempted. Certificate coursework is not used to determine eligibility for graduation honors.

- Summa Cum Laude 3.8 to 4.0
- Magna Cum Laude 3.6 to 3.79
- Cum Laude 3.3 to 3.59

## Valedictorian and Salutatorian

The Valedictorian and Salutatorian are the students with the two highest cumulative grade-point averages in the actual graduating class. The GPA is based on graduate status obtained at the end of the fall semester. The Valedictorian is the graduate with the highest grade-point average. The Salutatorian is the graduate with the second highest grade-point average.

Students who petition in the spring semester are considered candidates for graduation, and will not be considered graduates until all grades have been evaluated. These students are not eligible for consideration for Valedictorian, Salutatorian nor graduation honors at the commencement ceremony. When final grades are evaluated, if the student has met the requirements to receive honors, his/her degree will reflect honor status.

## HONORS PROGRAM REQUIREMENTS

The Honors Program offers students a dynamic, enriching academic experience while completing a curriculum of transferable general education classes. This program is designed for academically prepared, transfer-ready, highly motivated students. Honors classes are designed to encourage student participation and critical thinking expression. These courses are challenging and enhance intellectual skills necessary for success at the university level. Small class sizes allow for increased student-instructor interaction. The Honors Program promotes transfer to a host of prestigious universities including UCLA, UC Irvine, UC Riverside, Pepperdine University, USC, and CSU campuses.

### To Qualify for the Honors Program

**High School Students:** Students entering the program directly from high school or who are concurrently enrolled are required to have a cumulative 3.0 GPA or better and must qualify for English 101 on the LASC placement exam, complete English 28, have a score of 3, 4, or 5 on an AP English Literature or AP English Language exam, or complete the Southwest equivalent to English 101 at another college.

**Continuing College Students:** Students already attending LASC are required to have a minimum of 12 units of UC/CSU transferable coursework completed and a 3.25 GPA or better in all transferable courses to enter the program. Students must also be eligible for English

101 either through the LASC English placement exam, by completing the necessary prerequisite courses to English 101, or by completing the LASC equivalent to English 101 at another college.

### **To Apply to the Honors Program**

1. Complete an Honors Program application and essay
2. Provide verification of English 101 eligibility as noted above. Official transcripts from colleges outside of the LACCD must be mailed to the LASC Admission and Records Office.
3. Submit a letter of recommendation from a LASC instructor
4. Eligible candidates will be invited for an interview with the Honors Director and Honors Counselor

### **Program Requirements**

Honors Program requirements include:

- Completion of (15) units of Honors coursework
- Maintaining a cumulative 3.25 GPA in all UC/CSU transferable coursework
- Attendance to Honors Seminar meetings
- Completion of an Honors project before exiting out of the program

### **Program Benefits**

- Specialized Honors counseling and mentoring
- Honors recognition on the transcript for each Honors course completed
- Smaller class sizes
- Membership into the Beta Pi Omega Chapter of Phi Theta Kappa International Honor Society
- National Society of Collegiate Scholars affiliation
- UCLA library privileges, field trips to colleges and universities, and attendance to cultural events and research conferences.

## ACADEMIC PROBATION & DISMISSAL

### **Academic Standards for Probation**

The following standards for academic and progress probation shall be applied as required by regulations adopted by the Board of Governors of the California Community Colleges.

For the purpose of determining academic probation or progress probation, “units enrolled” means all units of credit in the LACCD for which the student is enrolled after census, and “units attempted” means all units of credit in the LACCD.

### **Dismissal**

A student on academic or progress probation for three consecutive semesters may be dismissed from the college. Academic probation is reached when a student has attempted a minimum of 12 semester units of work and has a grade-point average of less than a “C” (2.0). Progress probation is reached when a student has enrolled in a minimum of 12 semester units and the percentage of all units in which a student has enrolled for which entries of “W” (Withdrawal), “I” (Incomplete), and “NP” (No Pass) are recorded reaches or exceeds fifty



percent (50%). Once dismissed, the student may not attend any college within the Los Angeles Community College District for a period of one year and must petition for re-admission at the end of that period of time.

### **Appeal of Dismissal**

A student has the right to file a written petition with the college Student Success and Support Program Office to appeal a proposed dismissal action, if he/she experienced extenuating circumstances beyond his/her control that warrant an exception to the proposed dismissal. The student must file a written appeal within fifteen (15) calendar days after the dismissal notification was sent. If the student fails to file a written petition within the 15-day period, the student waives all future rights to appeal the dismissal action. The petition must include a clear statement of the grounds on which continued enrollment should be granted, and evidence supporting the request. The student will be continued on probation until the appeal is concluded. The student will be notified within 15 calendar days of the filing deadline. The student may appeal the decision of the Appeals Committee, in writing, to the College President or designee within 5 working days of the date of notification. The decision of the LASC President or designee, is final. If the appeal of the dismissal is granted, the student will be continued on probation for an additional semester. At the end of that semester, the student's academic record will be evaluated to determine whether the student shall be removed from probation, dismissed, or continue on probation.

### **Readmission After Dismissal**

A student who has been dismissed may request reinstatement after two (2) semesters have elapsed. The student shall submit a written petition requesting readmission to college in compliance with College procedures. Readmission may be granted, denied, or postponed based on evaluation of uniform criteria. escribed by the Board of Trustees. The following criteria will be considered in reviewing individual situations:

1. Documented extenuating circumstances presented during their appeal,
2. Marked improvement at an educational institution outside of the LACCD during the time the disqualification was in effect,
3. Semesters on which disqualification was based were atypical of past academic performance,
4. Improved GPA as a result of grade changes, fulfillment of incompletes, or academic renewal.

### **Notification of Probation and Loss of BOG Fee Waiver**

Each student will receive notification of academic or progress probation status no more than 30 days after the end of the term that resulted in academic or progress probation.

Reasonable efforts will be made to provide counseling and other support services to help students on probation overcome academic difficulties. The College will help mitigate potential loss of the BOG Fee Waiver and ensure that students have the opportunity to receive appropriate counseling, assessment, advising, and other services on a timely basis.

Reasonable efforts will be made to notify students of removal from probation, reinstatement after dismissal, and restoration of BOG Fee Waiver within timelines established by LACCD.

## 1. Notification Timeline

- a. At the end of the first semester and in each subsequent semester for which the student is on academic or progress probation, the student will receive an electronic notification of their academic or progress probation status no more than 30 days after the end of the term that resulted in academic or progress probation. The notification will also inform students of available college support services and the procedure to appeal the loss of BOG Fee Waiver.

A student who is placed on academic or progress probation may submit a written appeal in compliance with regulations issued by the Chancellor. A student who has lost the BOG Fee Waiver due to academic standing may submit a written appeal of that standing in accordance with existing regulations issued by the Chancellor.

## 2. Removal from Probation and Reinstatement of BOG Fee Waiver

A student shall be removed from academic or progress probation and have their fee waiver restored upon meeting the following criteria:

- a. Academic Probation - The student shall be removed from academic probation when his/her cumulative grade point average is 2.0 or higher.
- b. Progress Probation - The student shall be removed from progress probation when the percentage of units for which entries of "W" (Withdrawal), "I" (Incomplete), "NC" (No Credit) or "NP" (No Pass) are recorded drops below fifty percent (50%).

A student may retain or reinstate the BOG Fee Waiver based on achieving the minimum grade point average or progress standard defined above.

## 3. Electronic Notification: Students will be notified via their District assigned student email.

- a. Probationary Notification: The electronic communication notifying the student of his/her probationary status will cover, at a minimum, the explanation of the significance of being on probation, procedures to appeal loss of free waiver eligibility, and description of the available services.
- b. Dismissal Notification: The electronic communication notifying the student that he/she is subject to dismissal will cover, at a minimum, the reference to appropriate Board Rules, explanation of what dismissal means, procedure for reinstatement, and procedure to appeal dismissal.

## Probation

A student shall be placed on probation if any one of the following conditions prevail:

1. Academic Probation: The student has attempted a minimum of 12 semester units of work and has a grade-point average less than a "C" (2.0).

A student on academic probation for a grade-point deficiency shall be removed from probation when the student's cumulative grade-point average is 2.0 or higher.

A student on academic probation for two consecutive semesters shall lose Group 2 priority registration eligibility and BOG Fee Waiver eligibility. Loss of eligibility shall become effective at the first registration opportunity after such determination is made.





2. Progress Probation: The student has enrolled in a total of at least 12 semester units and the percentage of all units in which a student has enrolled and for which entries of “W” (Withdrawal), “I” (Incomplete), and “NP” (No Pass) are recorded reaches or exceeds fifty percent (50%).

A student on progress probation for two consecutive semesters shall lose Group 2 priority registration eligibility and BOG Fee Waiver eligibility. Loss of eligibility shall become effective at the first registration opportunity after such determination is made.

Foster youth, or former foster youth under the age of 24, are exempt from the loss of fee waiver due to academic or progress probation.

## OFFICE OF THE PRESIDENT

Cox Annex, Room 156

323-241-5273 Fax: 323-241-5220

[www.lasc.edu/administration/ootp/index.html](http://www.lasc.edu/administration/ootp/index.html)

Dr. Denise Noldon, Interim President

Jose A. Gallegos, Dean, Institutional Advancement

Chauncine R. Stewart, Executive Assistant (Confidential)

Ivee Baquir-Streator, Senior Secretary

Benjamin K. Demers, Public Information Officer

La Vonne Hamilton, Research Analyst





## STUDENT SERVICES

Student Service Building, Room 209  
 323-241-5298  
[www.lasc.edu/administration/student\\_services/](http://www.lasc.edu/administration/student_services/)

Dr. Howard Irvin, Vice President, Student Services

Reginald Morris, Dean, Student Services  
 Rahmani Byley, Administrative Secretary

LASC's Office of Student Services houses a variety of programs, services, and resources designed to support students inside and outside of the classroom. We look to challenge and support our students on their journey through college and towards graduation. Our resources ensure success not only while students are here at LASC, but also as they transfer to four-year schools and transition into the world of work.

Student Services is committed to the business of helping students develop and build character that encourages them not only to believe in themselves, but to strive to be distinguished members of our community. It is part of LASC's vision to be recognized as a college of excellence that fosters holistic growth for all of its students, and as an educational setting where academic achievement and social development are equally valued. To reach this goal, the college will provide students with the opportunity to realize self-worth, enhance ethical consciousness, exhibit interpersonal skills, respect cultural diversity, demonstrate critical thinking skills, make informed decisions about their future, demonstrate employment-related skills, function as responsible and productive citizens, enrich others through shared experience, and value life-long learning.

### **STUDENT SERVICES PROGRAMS & SERVICES**

Student Services provides a wide array of programs and services to fulfill the needs of LASC's diverse student body. Click the links below to explore all of its programs.

Admissions & Records  
 Financial Aid  
 Student Success Services Program (SSSP)  
 Associated Student Organization (ASO)  
 Health Center  
 Honor Society  
 International Student Center  
 Veteran Services  
 Community Services  
 Outreach & Recruitment

Counseling Services  
 General Counseling  
 CalWORKs/GAIN  
 Disabled Students Program & Services (DSPS)  
 EOPS/CARE  
 Freshman Year Experience (FYE)  
 Passage Program  
 Puente Program  
 Transfer Center

TRiO Programs  
 Educational Talent Search  
 Upward Bound  
 TRiO Scholars  
 TRiO STEM



## FINANCIAL AID

[http://www.lasc.edu/students/financial\\_aid/applying\\_for\\_financial\\_aid.html](http://www.lasc.edu/students/financial_aid/applying_for_financial_aid.html)

Financial Aid Office

Student Services Building (SSB), Room 104

323-241-5389

Munice Bruton, Financial Aid Manager (Provisional)

Nicolas Ward, Accounting Technician

### Financial Aid Technicians

Julio Carrillo

Piedad Chapa

Lisa Craig

Ernesto Rodriguez

Paris Watts

Sheryl Williams

The federal government, the State of California, and the Los Angeles Community College District offer eligible students a range of financial aid opportunities. A student or applicant who needs financial aid should apply as early as possible – even before completing an application for admission. Most student financial aid is provided in the form of grants through federal and state-funded programs. This money is specifically awarded for education-related expenses including tuition, fees, books, and indirect costs such as living expenses and transportation. Eligibility depends upon financial need. Additional financial aid may be available through private scholarships or from outside agencies.

### **What is Financial Aid?**

Financial aid is made available by federal and state governments and private sources in the forms of grants, scholarships, employment, and loans. This assistance makes it possible for students to continue their education beyond high school, even if they and/or their family cannot meet the full cost of the postsecondary college they choose to attend. The basis for such assistance is the belief that students and their families have the primary responsibility to assist their dependents in meeting educational costs. Financial Aid is meant to supplement your existing income/financial resources and should not be depended upon as your sole means of income to support other non-educational expenses.

We encourage all students to apply using the online Free Application for Federal Student Aid (FAFSA) so that they will be considered for all of the federal and state financial aid programs.

### **Who is Eligible for Financial Aid?**

- To be considered for financial aid, students must meet the following minimum requirements:
- For federal aid eligibility, be a U.S. citizen or an eligible non-citizen. An eligible non-citizen is a U.S. permanent resident who has documentation from the Department of Homeland Security verifying that his/her stay in the U.S. is for other than a temporary purpose.
- For state aid eligibility, be either a 1) U.S. citizen or eligible non-citizen, or 2) be classified as an AB 540 student by your college's Admissions and Records Office.
- Demonstrate financial need (for most programs).
- Have a high school diploma or a recognized equivalent such as a General Education (GED) certificate, passed a high school proficiency examination, such as the HISET, or completed a high school education in a home-school setting. Students who were enrolled in a college or university prior to July 1, 2012 who do not meet this requirement should check with their Financial Aid Office for alternative qualifying options.
- Be enrolled as a regular student in an eligible Associate Degree, transfer program, or



certificate program.

- Be making Satisfactory Academic Progress in a course of study leading to a Certificate, AA, or AS degree, or Transfer to a Baccalaureate Degree Program.
- Not be in default on any student loans such as Federal Perkins Loans, Federal Stafford Loans (subsidized and/or unsubsidized), Federal Direct Loans (subsidized and/or unsubsidized) or Supplemental Loans to Assist Students (SLS) at any college attended.
- Not owe an overpayment on a Federal Pell Grant, Federal Supplemental Educational Opportunity Grant (FSEOG), Academic Competitiveness Grant (ACG), SMART Grant or Iraq and Afghanistan Service Grant.
- Be registered with the Selective Service if required to do so.
- Have a valid Social Security Number (SSN) for federal aid eligibility.
- Resolved all drug conviction issues.
- File a federal income tax return if required to do so.

### **Net Price Calculator**

The federal government requires all colleges and universities to have a “Net Price Calculator” on their websites, with the goal of giving individual students and their families a clearer sense of how much they themselves might pay for a degree at a particular institution. The Net Price Calculator is found on the Financial Aid webpage at [www.lasc.edu/students/financial\\_aid/applying\\_for\\_financial\\_aid.html](http://www.lasc.edu/students/financial_aid/applying_for_financial_aid.html). By providing the requested information, your responses will be used to calculate an estimated amount that students like you paid - after grant aid and scholarships but before student loans - to attend LASC in a given year.

### **How do I Apply for Financial Aid?**

Students are encouraged to apply for financial aid online at [www.fafsa.ed.gov](http://www.fafsa.ed.gov) or at [www.caldreamact.org](http://www.caldreamact.org) for AB540 Students. Processing is fastest and most accurate when completing your application online. Prior to applying online, visit <https://fsaid.ed.gov> to obtain a Federal ID so that you may electronically sign your FAFSA. If you are a dependent student, your parent(s) may also apply for a PIN. As instructed on the website, if you do not have a PIN for electronic signature, be sure to print and mail the signature page when you transmit your application.

Paper FAFSAs are also available. You may print one from the websites above or may contact the Federal Student Information Center at 800-433-3243 (for FAFSA) or the California Student Aid Commission at 888-224-7268 (for the California Dream Act Application).

Be sure to list the correct Title V Federal School Code. The College’s federal school code is: **007047**.

### **When Should I Apply for Financial Aid?**

The Priority Application Date for Each Academic Year is May 1st

May 1st of each year is the priority date for the following fall and spring semesters. Students should submit all required documents needed to process their application to the Financial Aid office by the priority date of May 1st. The priority date is established to encourage early application for financial aid. Students who have missed the priority date may still apply, as funds may be available.

For each financial aid award year, the Free Application for Federal Student (FAFSA) application may be completed on or after October 1st. FAFSA applications will be accepted until June 30th of each year.

Contact the Financial Aid office at 323-241-5338 or in SSB, Room104 for more information.

## Important Deadlines

Failure to meet deadlines will result in denial of aid for the entire award year.

### What Happens After I Apply for Financial Aid?

After you submit your FAFSA, you will receive a Student Aid Report (SAR), and the college will receive your record electronically if you listed LASC's federal school code (007047) on your FAFSA. Review the SAR to make sure it is accurate. If any information is incorrect, contact the Financial Aid Office if you need assistance with making corrections.

When the college receives your information, you will receive a Document Tracking Letter requesting documents or forms to complete your financial aid file. You will automatically be considered for the Board of Governors Fee Waiver (BOGFW), provided eligibility exists. A separate BOGFW application is not needed.

After your file is complete, it will be reviewed and your financial aid eligibility (need) will be determined. If you are eligible for financial aid, you will receive an award letter that details the financial aid you have been awarded.

### Enrollment at Other Colleges

Consortium Agreements are in effect for all colleges within the Los Angeles Community College District (LACCD). If you are attending more than one college within the District in the same period, Pell and Cal Grant payments will be based on all units taken. For all other programs, a six unit minimum enrollment is required at the home campus. If you plan to enroll in courses outside of LACCD and wish to have those courses count for enrollment and payment, you must complete a consortium agreement. Please note: Payments for courses outside of LACCD will be paid after the grades are submitted to the Financial Aid Office.

### ITV Classes

Students taking ITV courses must be enrolled in at least one (1) unit at the school (home school) that is processing their financial aid in order to receive Pell and Cal Grant payments, provided eligibility exists. For all other programs, students must be enrolled in a minimum of six (6) units at the home school; units from other colleges may not be combined for all other programs. Students enrolled in ITV courses receive their transcripts for those courses from Los Angeles Mission College. Students enrolled only in ITV courses who wish to be considered for financial aid must apply to Los Angeles Mission College as the home school for financial purposes.

ITV classes are included in disbursements for all other classes.

### How Do I Receive My Financial Aid?

LASC issues financial aid disbursements through BankMobile.

If you are eligible for a financial aid disbursement you will receive information in the mail instructing you on setting up your disbursement account.

1. Check your mail for the bright green envelope.
2. Use your Personal Code found inside the envelope to select your refund preference. Hint: it will look like ABCD-1234-5678.
3. Click "Let's Get Started" and chose how you would like to receive your refund.

BankMobile Customer Service for students:

General email: [help@bankmobile.com](mailto:help@bankmobile.com)

Email questions: [vibe@email.bankmobilevibe.com](mailto:vibe@email.bankmobilevibe.com)

Phone: 844-WOW-BANK (844-969-2265)



## Board of Governors Fee Waiver (BOGFW)

The BOGFW is offered by the California Community Colleges. Under this program, enrollment fees are waived for students who qualify. Applicants do not have to be enrolled in a specific number of units or courses to receive the BOGFW, and no repayment of funds is required. California residents who are enrolled in at least one (1) unit are eligible for this fee waiver. Non-resident students are not eligible for the BOGFW.

Health fees are not waived as part of the BOGFW. However, if a student does receive financial aid, the health fee will be deducted from the award package. Contact the Financial Aid Office if you have any questions.

If you need additional help beyond the BOGFW to cover some of your educational expenses, you must complete the Free Application for Federal Aid (FAFSA). We encourage all students to apply using the FAFSA so that they will be considered for all of the federal and state financial aid programs.

There are three ways to qualify for a BOGFW:

1. At time of enrollment, you or (if you are dependent student) your parent(s) must be a recipient of TANF, CalWORKs, SSI/SSP, or General Assistance (GA);
2. You or (if you are a dependent student) your parent(s) must meet the following income standards:

Family Size 2014 Income

1	\$17,505
2	\$23,595
3	\$29,685
4	\$35,775
5	\$41,865
6	\$47,955
7	\$54,045
8	\$60,135

Each additional member add \$6,090;

3. If you are not eligible for a fee waiver based on the criteria listed above, you may still be eligible if you apply for need-based aid through the FAFSA.

**Important Change to Calculation of BOGFW Eligibility:** New administrative methods will limit BOGFW eligibility to students whose financial need is at least equal to the enrollment fees for a full-time student (12 units per term). For 2012-13, minimum need is \$1,104. Students will remain eligible for a BOGFW to cover any number of units as long as they demonstrate financial need equal to or greater than the minimum. In the past, eligible students had all enrollment fees waived regardless of the amount, allowing students to receive fee waivers in excess of their financial need.

You may also qualify for a BOGFW if any of the following categories listed below apply to you.

### Dependent Fee Waiver

You are eligible if you have a Certification from the California Department of Veteran Affairs or the National Guard Adjutant General that you qualify for a Dependent's Fee Waiver. If you are a dependent of a deceased law enforcement/fire suppression personnel killed in the line of duty, you must show proof of benefits.

## **Congressional Medal of Honor**

If you are a recipient of the Congressional Medal of Honor or a child of a recipient, submit documentation from the Department of Veterans Affairs.

## **Surviving Dependents of Terrorist Attacks 9/11/2001**

You are eligible if you are a dependent of a victim of the September 11, 2001 terrorist attacks. Submit documentation from the California Victim Compensation and Government Claims Board.

## **FEDERAL FINANCIAL AID PROGRAMS**

### **Federal Pell Grant Program**

The Federal Pell Grant provides gift aid assistance to undergraduates who have not yet earned a baccalaureate or first professional degree and who demonstrate financial need. Awards are based on the student's Expected Family Contribution (EFC) and enrollment status. The EFC is calculated based on the information such as income and assets on the FAFSA. The lifetime limit for the Pell Grant is 12 full-time semesters. The lifetime Pell Grant limit applies to new and continuing students.

### **Federal Supplemental Educational Opportunity Grant (FSEOG)**

The FSEOG is a federal grant program designed to supplement other sources of financial aid for students with exceptional need. FSEOG awards are based on financial need and fund availability.

### **Federal Work Study (FWS)**

The Federal Work-Study Program (FWS) enables students to earn a portion of their financial aid award through part-time employment either on or off campus. To be eligible, a student must meet the eligibility requirements for federal financial aid and must maintain good academic standing while employed under the program.

### **Federal Student Loans (Funds You Must Repay)**

You are not obligated to borrow a loan. All loans require a minimum unit enrollment of six (6) approved units at Los Angeles Southwest College. If you have defaulted on a student loan, you are ineligible for financial aid with the exception of a Board of Governors Fee Waiver Program. Contact the Financial Aid Office to discuss possible options for resolving your student loan default.

Students who request a loan are required to take online Loan Entrance and Exit Counseling Session in addition to online financial literary sessions. These sessions inform the borrower about his/her rights and responsibilities as a student borrower as well as provide budgeting and financial management advice.

- **Federal Perkins Loan Program** - The Federal Perkins Loan Program is a low 5% interest loan to help students with exceptional need meet their educational expenses. Loan amounts will be determined annually based on funding. Priority funding will be given to students who submit all paperwork by the May 1st priority date.
- **William D. Ford Federal Direct Loan Program** - Federal Direct Loans (Subsidized and Unsubsidized) are loans borrowed from the federal government (which serves as the lender) and must be repaid.
  - o Subsidized Direct Loan: Interest does not accrue on a subsidized loan while students are enrolled in school at least half-time (six (6) units) and during the six-month grace period after they leave school. Loans made on or after July 1, 2012 and before July 1, 2014 will not be eligible for an interest subsidy during the six-month grace period. If you receive a loan during this time frame, you will be responsible for





the interest that accrues while your loan is in the grace period.

- o **Unsubsidized Direct Loans:** Interest begins accruing on an unsubsidized loan at the date of disbursement by the lender. Students must pay the interest or allow it to be capitalized (added to the principal or original loan amount) while they are enrolled in school in at least half-time (six (6) units) and during the grace period.

The current (2016-2017) interest rate charged on a Direct Subsidized Loan is fixed at 3.76%, the interest rate for a Direct Unsubsidized Loan is 3.76%. These rates are applicable to loans disbursed on or after July 1st, 2016. Visit <http://studentaid.ed.gov/> to obtain the current loan interest rate, repayment, deferment, cancellation, and consolidation information.

**Important Message About Student Loans:** Should a student experience unforeseen circumstances with any of the loan programs discussed that prevent repayment at the minimum level, contact the Financial Aid Office or the Loan Servicing Center immediately. We do not want you to default on your student loan(s) because there are serious consequences which will negatively affect your future. There may be other options available, so please do not hesitate to contact the Financial Aid Office.

### **Bureau of Indian Education (BIE) Higher Education Grant Program**

The purpose of the BIE Higher Education Grant Program is to provide supplemental financial assistance to the eligible American Indian/Alaska Native scholar entering college seeking a baccalaureate degree. A student must comply with eligibility criteria:

1. Must be a member of, or at least one-quarter degree Indian blood descendent of a member of an American Indian tribe that is eligible for the special programs and services provided by the United States through the BIE because of their status as Indians,
2. Must be accepted for admission to a nationally accredited institution of higher education that provides a course of study conferring the Associate of Arts or Bachelor's degree,
3. Must demonstrate financial need as determined by the financial aid officer of the collegiate institution.

The grant application is available with the education officer of the tribe in which you are affiliated or possess membership. For grant applications, you may also write to: Office of Indian Education, 2800 Cottage Way, Sacramento, California 95825, or you may call (916) 978-6057. Be sure to inform the Financial Aid Office that you are tribal and will be submitting a grant application along with other financial aid applications.

### **American Opportunity Tax Credit**

The Tax Relief Act of 1997 created two programs that might be useful to students or their parents. The American Opportunity Tax Credit will expire in December 2017.

- **Hope Credit** – Provides up to \$2,500 in tax credit for tuition and requires fees for the first two years of college for students enrolled at least half-time. The credit for most in-state students would be much less because of our low cost. Students whose fees are waived through the Board of Governors Fee Waiver program or whose fees are covered by a scholarship or grant would not be eligible to take the tax credit.
- **Lifetime Learning Credit** – Families can receive a 20% tax credit for the first \$10,000 of tuition and required fees paid each year. The maximum credit is determined on a per-taxpayer (family) basis, regardless of the number of postsecondary students in the family. Students whose fees are covered by a fee waiver, scholarship, or grant would not be able to add their costs to their families for tax credit calculation.

You should consult a tax professional for further details on the tax credits, including phase-out of eligibility depending on the family's adjusted gross income. Consult the following website for additional information: <http://www.irs.gov/newsroom/article/0,,id=205674,00.html>

## STATE FINANCIAL AID PROGRAMS

### Board of Governors Fee Waiver (BOGFW) Program

The Board of Governors Fee Waiver Program is offered by the California Community Colleges. Refer to information provided earlier in the Financial Aid section.

### Cal Grants

Students must meet the following eligibility requirements for the Cal Grant Programs:

- Be a U.S. citizen or permanent resident,
- Have a valid Social Security Number (SSN),
- Be a California resident ,
- Be attending at least half-time at a qualifying California college,
- Have financial need at the college of attendance ,
- Be making satisfactory academic progress as determined by the college,
- Have not already earned a bachelor's or professional degree, or the equivalent.

Students must complete a FAFSA to apply for the Cal Grant Programs.

**Deadline date:** First deadline is March 2nd of each year. A second deadline for community college applicants is September 2nd of each year, but we highly recommend that applicants meet the March 2nd deadline when more funding is available.

Grade Point Average (GPA) Verification is required for Cal Grant A and B awards. Students must submit a GPA Verification Form by March 2nd of each year to the California Student Aid Commission. GPA verification for students enrolled within the Los Angeles Community College District will be electronically sent to the Commission by the deadline date for those who meet specific criteria. Contact the Financial Aid Office to see if you meet the criteria to have your GPA electronically sent and for other possible options.

### Entitlement Grants

- *Cal Grant A* provides grant funds to help pay for tuition/fees at qualifying institutions offering baccalaureate degree programs. If you receive a Cal Grant A but choose to attend a California Community College first, your award will be held in reserve for up to three years until you transfer to a four-year college.
- *Cal Grant B* provides subsistence payments for new recipients in the amount of \$1656 for a full-time, full year award. Payments are reduced accordingly for three-quarter and half-time enrollment for each payment period. Cal Grant B recipients who transfer to a tuition/fee charging school after completing one or two years at a community college will have their grant increased to include tuition and fees as well as subsistence.
- *Cal Grant Transfer Entitlement Award* is for all community college students who are transferring to a four-year college and are under age 24 as of December 31st of the award year.

### Competitive Grants

- *Cal Grant A and B* competitive awards are used for the same purpose as the A and B entitlement awards, except that they are not guaranteed and the number of awards is limited.
- *Cal Grant C* recipients are selected based on financial need and vocational aptitude. Students must be enrolled in a vocational program at a California Community College, independent college, or vocational school, in a course of study lasting from four months to two years. Cal C awards may not be used to pursue a four-year degree program, graduate study, or general education.



To find out more on the various Cal Grant Programs, visit the California Student Aid Commission's website at: [www.csac.ca.gov](http://www.csac.ca.gov).

### **Child Development Teacher Grant**

This program is a need-based grant designed to encourage students to enter the field of child care and development in a licensed children's center. Students who plan to enroll at least half-time in coursework leading to a Child Development Permit as a teacher, master teacher, site supervisor, or program director, are eligible to apply through the college they plan to attend. For more information, visit [www.csac.ca.gov](http://www.csac.ca.gov) or call (888) 224-7268, Option #3.

### **Chafee Grant**

The California Chafee Grant is a federal grant administered by the California Student Aid Commission and provides assistance to current or former foster youth to use for college courses or vocational school training. Eligible students may receive up to \$5,000 per academic year. To learn more about this program and to apply online, go to <https://www.chafee.csac.ca.gov/default.aspx>

### **Dream Act**

The California Dream Act allows students who meet AB540 criteria to apply for and receive certain state and institutional financial assistance programs. In order to meet AB540 requirements:

- Have attended a CA high school for at least three years or graduated early from a CA high school with the equivalent of three or more years of credit\*, and
- Graduated from a CA high school, or passed the High School Equivalency Test (HSET), or obtained a Certificate of General Education Development (GED), and
- Enrolled in an accredited and qualifying CA college or university, and
- If applicable, complete (d) an affidavit to legalize immigration status as soon as you are eligible.

\*If students graduated early from high school under this provision, they must also have attended CA schools (elementary and secondary) for a cumulative total of three or more years.

For additional information to determine if you meet the AB540 requirements, contact the Office of Admissions and Records. Visit the [Financial Aid Office webpages](#) for more information regarding the Dream Act and to apply for financial aid under Dream Act provisions.

### **Law Enforcement Personnel Dependents Grant Program**

The Law Enforcement Personnel Dependents (LEPD) Grant is a program administered by the California Student Aid Commission that provides grants for eligible students. Students must meet the following eligibility:

- Students must be a child (natural or adopted) or spouse, at the time of death or injury of a California peace officer or law enforcement officer, officer or employee of the Department of Corrections or the Department of Youth Authority, or firefighter;
- Be enrolled in a minimum of six units at a California postsecondary institution accredited by the Western Association of Schools and Colleges;
- Demonstrate financial need as determined by the Financial Aid Office at the institution in which students are enrolled.

The grant will be in an amount equal to the amount provided to a student who has been awarded a Cal Grant. Awards may be used for tuition and fees, books, supplies, and living

expenses.

Obtain an application by calling the California Student Aid Commission's Specialized Programs Branch at (888) 224-7268 (select menu option #3), or submit a request in writing to [specialized@csac.ca.gov](mailto:specialized@csac.ca.gov). For more information on this grant program, go to [www.csac.ca.gov](http://www.csac.ca.gov) and link to "Publications" and then "Program Fact Sheets."

## OTHER FINANCIAL AID RESOURCES

### Scholarships

Throughout the year each campus receives announcements about scholarship opportunities. The focus of each scholarship is different. Some require financial need and some are for outstanding performance regardless of the student's major field of study. Information about scholarships is available in the Financial Aid Office and online at

[http://www.lasc.edu/students/financial\\_aid/scholarship\\_resources\\_and\\_links.html](http://www.lasc.edu/students/financial_aid/scholarship_resources_and_links.html)

### Other Agencies

Some students may qualify for the following programs:

- Veterans Benefits
- Vocational Rehabilitation Assistance
- AmeriCorps

Contact the appropriate off-campus agency for more details.

### Special Circumstances

In certain cases, a family's financial situation can change because of:

- Death in the family
- Separation or divorce
- Loss of employment
- Loss of non-taxable income or benefits

In such cases, the student should contact the Financial Aid Office.

### Change of Enrollment/Recalculation/Overpayment

If your enrollment status changes during the semester, inform the Financial Aid Office. Your financial aid award may be modified to reflect the correct number of units in which you were enrolled at the time of the second disbursement. The adjustment of enrollment may cause an overpayment of financial aid funds. Repayment of financial aid funds is necessary if the adjustment of enrollment causes an overpayment. You must resolve your overpayment prior to receiving any additional financial aid. Having an overpayment of federal funds will prevent you from receiving federal financial aid from any institution.

### Return of Title IV Funds Policy

Students who receive federal financial aid and then withdraw from all classes may have to repay some of the federal funds they received.

All students receiving federal aid who withdraw from the institution in the first 60% of the term are subject to Return Regulations. The Financial Aid Office will calculate the amount of federal funds earned up to the point of withdrawal and students will be billed and must repay any federal grant funds received but not earned. Failure to repay these funds will result in the denial of future federal financial aid at all colleges.

It is advised that you contact the Financial Aid Office before withdrawing from all of your



classes so you understand the results of your actions. For the refund policy on enrollment fees and non-resident tuition, see the current Schedule of Classes.

## **Student Rights and Responsibilities**

### **Students may inquire about the following at the Financial Aid Office:**

1. Information on all financial assistance available, which includes all federal, state, and institutional financial aid programs.
2. Disclosure of deadlines for applications of each financial aid program and for any supporting documentation.
3. Specific information regarding fees for those who drop out of school.
4. An explanation of how students are selected for receipt of financial aid and how financial aid need is determined. This process includes a consideration of costs of tuition and fees, books and supplies, room and board, transportation, personal and miscellaneous expenses, child care, etc., plus the student's income and assets, parental contribution, other financial aid (such as scholarships), and so on.
5. Knowledge of what resources are considered in the calculation of student need.
6. Knowledge of how a financial aid package is determined.
7. An explanation of various programs awarded in the student's financial aid package. If a student feels he/she has been treated unfairly, a reconsideration of the award may be requested.
8. An explanation of the portion of financial aid the student received that must be repaid and what portion is grant aid or work-study and does not need to be repaid. If the aid is a loan, the student is informed during the loan counseling sessions about what the interest rate is, the total amount to be repaid, when the repayment is to begin, and the conditions of deferment and cancellation.
9. Knowledge of how the Los Angeles Community College District determines whether students are making "satisfactory academic progress" and what happens if they are not.
10. Knowledge of what facilities are available for disabled students.

### **Students must take responsibility for:**

1. Having a valid Social Security Number (SSN) on file in the Admissions and Records Office for the purpose of reporting a Cal Grant Grade Point Average and loan deferments, etc.
2. Enrolling in an eligible program, which is defined as a Certificate, or an Associate's Degree (AA/AS), or a two-year academic Transfer Program that is acceptable for full credit toward a Baccalaureate Degree. Students must declare an educational goal and major, and update changes with the Admissions and Records Office.
3. Maintaining Satisfactory Academic Progress to receive financial aid and meeting with an academic counselor to develop or review an Educational Plan (Satisfactory Academic Progress Policy is also in the catalog).
4. Submitting all financial aid applications and documents by specified deadlines.
5. Completing all financial aid application forms accurately and completely. If this is not done, aid could be delayed. Errors must be corrected before any financial aid can be received.
6. Reading and understanding all financial aid forms and information. We advise students to retain copies of all documents submitted.
7. Choosing a home school to process financial aid. Students may not receive financial aid from two or more institutions at the same time or periods of overlapping terms.
8. Notifying the appropriate entity (college, lender, California Student Aid Commission, U.S.



Department of Education, etc.) of changes in your name, address, school enrollment status, or transfer to another college.

## **SATISFACTORY ACADEMIC PROGRESS POLICY**

### **General Information**

In accordance with the Higher Education Act of 1965, as amended, the Los Angeles Community College District (LACCD) established the following Standards of Academic Progress. These Standards apply to all students who apply for and receive financial aid from the programs listed below:

- Federal Pell Grant
- Iraq and Afghanistan Service Grant
- Federal Supplemental Educational Opportunity Grant (FSEOG)
- Federal Work Study (FWS)
- Federal Perkins Loan
- Federal Nursing Loan
- Federal Direct Stafford (student) and PLUS (parent) Loans
- Cal Grant (B and C)
- Child Development Teacher Grant
- California Chafee Grant
- California National Guard Education Assistance Award Program (CNG EAAP)

Professional Judgment may be exercised in applying these standards in accordance with Section 479A of the Higher Education Act of 1965, as amended. Satisfactory Academic Progress Standards are reasonable if they are the same as or stricter than the institution's standards for a student enrolled in the same educational program who is not receiving assistance under Title IV Federal Financial Aid Programs. Current and previous coursework earned at any college within LACCD will be reviewed for compliance with the standards put forth in this policy.

### **Consortium Classes**

- All classes throughout the LACCD will be included when reviewing satisfactory academic progress.
- For students aided under a Consortium Agreement with a college outside the LACCD, consortium classes will be included during satisfactory academic progress review.
- Consortium Agreements are only approved for one semester at a time. Consortium Agreements are not approved retroactively. A completed Consortium Agreement (and proof of enrollment at the secondary college) must be received by the LASC Financial Aid Office prior to the last day of the semester listed on the form.

### **Repeated Coursework**

- Repeated coursework within the LACCD will be counted toward a student's attempted units.
- For repeated coursework for which a student has petitioned the college to utilize the most recent grade received, only the most recent grade received will be used for cumulative GPA calculation for SAP status determination.
- Transfer credits from institutions outside of LACCD will be used and evaluated for SAP

standing.

## General Requirements

Students receiving financial aid must be enrolled in an eligible program. An eligible program is defined as:

- An educational program that leads to an associate degree, or
- An educational program which is at least a two-year academic transfer program that is acceptable for full credit towards a bachelor's degree, or
- An educational program which is at least a one academic year training program that leads to a certificate, degree, or other recognized educational credential and that prepares a student for gainful employment in a recognized occupation.

## Satisfactory Academic Progress Standards

To meet satisfactory academic progress standards, student must meet the following criteria:

- Maintenance of a 2.0 or higher cumulative GPA.
- Completion of 67% cumulative units attempted.
  - Entries recorded in the students' academic record as Incomplete (INC), No Credit (NCR), and/or Withdrawal (W) are considered Non-Grades and must compose 33% or less of the cumulative units attempted.
- Fewer than ninety (90) attempted units for students who indicated AA degree, AS degree, or Transfer as their educational goal.
  - ESL and Basic Skills/Remedial classes are excluded from the ninety (90) unit limit when determining units attempted. Students may receive federal aid for up to 30 units of remedial coursework.
  - Students who have already earned an Associate or higher degree outside of the LACCD will need to follow the appeal procedure.
  - In Progress (IP) grades count as attempted units in the maximum time frame only. IP grades do not affect cumulative grade-point average in the qualitative measure nor are they included as completed units in the quantitative measure.

## Application of Standards

- Satisfactory Academic Progress standing for financial aid students will be determined at the end of each payment period/semester (Summer, Fall/Winter, or Spring semester).
- Students who are disqualified from financial aid will be notified by mail and receive information regarding the petition process.
- Students who have been disqualified at any college in the LACCD are disqualified at all colleges within the LACCD.
- **Disqualification:** Students will be disqualified if they have one or more of the following academic deficiencies:
  - Cumulative GPA is less than 2.0 following a semester for which the student received a Warning Letter.
  - Cumulative Non-Grades are greater than 33% following a semester for which the student received a Warning letter.
  - Total units attempted (excluding ESL and Basic Skills/Remedial classes) are equal to or greater than ninety (90).
  - An associate or higher degree has been earned outside LACCD.
- **Warning Letter:** Students will receive a Warning Letter (by mail or email) if they were initially in good standing (based on SAP standards) but at the end of their most current semester they show one or more of the following academic deficiencies:

- o Cumulative GPA is less than 2.0.
- o Cumulative Non-Grades are greater than 33%.

- **Advisory Letter:** Students will receive an Advisory Letter at the end of the first semester where their number of units attempted reaches forty-five (45).

### Maximum Time Length

Students attending for the purpose of obtaining an Associate of Arts Degree (AA), an Associate of Science Degree (AS), or completion of requirements for transfer to a four-year college are allowed 90 attempted units in which to complete their objective.

- Exceptions can be made when the requirements of a student’s objective cause the student to exceed the maximum time limit.
- A change of one educational goal or major course of study will be permitted. Students are eligible to receive financial aid for one educational goal at the institution of attendance.

### Short Length Certificate Programs

- Some certificate objectives at the LACCD colleges may be completed in less time than that required for the Associate in Arts, Associate in Science, and transfer programs.
- The following table shows the normal completion time and maximum time for certificate programs of varying length:

Units Required for the	Normal Length	Maximum Length
10 to 24	2 semesters	3 semesters
25 to 36	3 semesters	5 semesters
37 to 48	4 semesters	5 semesters

- To be eligible for financial aid, a program must be at least six (6) months in length with a minimum of sixteen (16) units. Students enrolled in a certificate program may continue to qualify for financial aid up to ninety (90) attempted units, six (6) full-time semesters, or the equivalent, if they are planning to obtain an AA or AS degree or to transfer to a four-year school in addition to obtaining the certificate.

### Summer and Winter Financial Aid

Summer and winter terms are included in the evaluation of Satisfactory Academic Progress Standards. Summer is considered a separate semester for evaluation purposes. Winter term, as it is combined with fall semester for payment purposes, will be included with Fall semester for SAP evaluation purposes.

### Petition Procedure for Reinstatement or Extension of Financial Aid Eligibility

- To petition for reinstatement or extension of financial aid eligibility, a student must file the appropriate petition form to the LASC Financial Aid Office (FAO). A student may obtain the appropriate Petition for Reinstatement form or Petition for Extension from the LASC FAO or from [http://www.lasc.edu/students/financial\\_aid/forms.html](http://www.lasc.edu/students/financial_aid/forms.html). Petition forms must be submitted to the LASC FAO with any supporting documentation the student wishes to have considered.
- Students submitting Petition for Extension forms must also submit a current Student Educational Plan (SEP) prepared by an academic counselor. The SEP should outline the





minimum required courses necessary to complete the student's educational program.

- Petition forms must be submitted before the end of the semester/term for which the student requests consideration of reinstatement or extension of financial aid eligibility.
- Students are not eligible for any federal or state aid (except for federal student (Direct Stafford) or parent (Direct PLUS) loans) retroactively for petitions received and approved after the payment period ends.
- Petitions forms should be completed in ink or typed and consist of a written statement from the student as to why he/she is appealing the disqualification. Additional information may be requested and supplied by the student which supports their rationale for requesting reinstatement or extension of financial aid eligibility.
- Upon receipt of the request, the Financial Aid Administrator (FAA) or designee shall consider the petition.
  - o The result of the petition will be provided to the student in writing within 30 calendar days.
  - o Students with an approved Petition for Reinstatement may be approved for more than one semester if the FAA sets forth terms of academic progress that the student must meet for continued eligibility. If the student is not meeting the terms of the approval, they will be disqualified from continued financial aid eligibility. Note: The FAA may approve a Petition for Reinstatement for a single semester, whereby the student must meet all SAP policy standards by the end of the semester to be eligible for continued financial aid eligibility.
  - o Students with an approved Petition for Extension will receive approval for only the minimum number of courses required to complete their educational program, as determined by the student's academic counselor and approved by the Financial Aid Administrator. Enrollment status for financial aid calculation purposes will be determined by enrollment in approved classes only.
  - o If a student's petition is denied, they may re-petition no more than two (2) additional times within a given semester/term, assuming all petitions are received and reviewed before the end of the specified semester/term.
  - o A District Appeal Review may be processed only after all College appeal procedures have been exhausted. A District Office review may be initiated by a student who reasonably believes that college, state, and/or federal guidelines were applied incorrectly and, therefore, adversely affected their financial aid status, rights and privileges.

### **State Tax Offset**

Students should be aware that state income tax refunds might be offset by the institution for repayment of financial aid funds if it is determined a student was ineligible to receive funds, has defaulted on a student loan, or owes other debts to the school.

### **Fraud**

- A student who attempts to obtain financial aid by fraud will be suspended from financial aid for unsatisfactory conduct.
- The college will report such instances to local law enforcement agencies, to the California Student Aid Commission, and/or to the federal government.
- Restitution of any financial aid received in such manner will be required.

## Financial Aid Related Websites

California Student Aid Commission

<http://www.csac.ca.gov/default.asp>

Information about California college grants, scholarships, student loans, and specialized financial aid programs.

Direct Loan Services Online

<http://www.dlsvicer.ed.gov/>

A site that enables Direct Loan borrowers to access current loan information.

FAFSA on the Web

<http://www.fafsa.ed.gov/>

You may use this online form to complete and submit the Free Application for Federal Student Aid over the internet.

FastWeb.com

<http://www.fastweb.com/>

FinAid - The Smart Student Guide to Financial Aid

<http://www.finaid.org/>

This page provides a free, comprehensive, independent, and objective guide to student financial aid.

Finding out about Financial Aid

<http://studentaid.ed.gov/PORTALSWebApp/students/english/index.jsp>

Information about student financial assistance from the U.S. Department of Education.

Firstgov

<http://www.firstgov.gov/>

A federal government website that offers links to many government sites.

Help in Completing the FAFSA

<http://studentaid.ed.gov/students/publications/completingfafsa/index.html>

A site dedicated to helping students complete the FAFSA application.

FSA ID

<https://studentaid.ed.gov/sa/fafsa/filling-out/fsaid#pin-replacement>

The FSA ID serves as your identifier to access your personal information in various U.S. Department of Education systems.

Veterans Benefits and Services

<http://www.gibill.va.gov/>

This site offers valuable information about programs and resources for Veteran students.

Other Financial Aid Sources

There are several sources of financial aid available, including, but not limited to:

- Veterans Benefits
- Vocational Rehabilitation Assistance
- Americorps

If you are eligible for any of these benefits, you are encouraged to apply because financial funds are limited. Contact the appropriate agency for more details.



## Telephone Numbers

### Federal Student Aid Information Center

For general information about federal student financial assistance programs, help completing the FAFSA, and to obtain federal student aid publications, call 1-800-4-FED-AID (1-800-433-3243). The TDD number for hearing-impaired individuals is 1-800-730-8913.

For a student to check on the status of the processing of his or her FAFSA or to request a copy of his or her SAR, call 1-319-337-5665\_

### FSA Ombudsman

For problems with a federal student loans, refer students to the FSA Ombudsman. The FSA Ombudsman will research the problem in an impartial and objective manner.

The FSA Ombudsman can be reached by phone at 1-877-557-2575, by fax at 1-202-275-0549, or by mail at U.S. Department of Education, FSA Ombudsman, 830 First Street, NE, Fourth Floor, Washington, DC 20202-5144.

### Bureau of Citizenship and Immigration Services

Previously known as the Immigration and Naturalization Service (INS), the Bureau of Citizenship and Immigration Services can answer questions relating to international students and visas, call 1-415-705-4205.

### Inspector General Hotline

To report fraud, waste, or abuse involving federal student aid funds, call 1-800-MIS-USED (1-800-647-8733).

### Internal Revenue Service (IRS)

For tax questions and copies of IRS publications, call 1-800-829-1040.

### National Service

For information about the National and Community Service Program, call 1-800-94-ACORPS (1-800-942-2677).

### OPE Customer Support

For OPE customer support, send email to [csb@ed.gov](mailto:csb@ed.gov) or fax 1-202-260-4199.

### Selective Services

For questions relating to selective service registration and financial aid eligibility, call 1-847-688-6888.

### Social Security Administration (SSA)

For questions relating to social security number problems such as a failed data match or conflicting information, call 1-800-772-1213

## ASSOCIATED STUDENTS ORGANIZATION (ASO)

[www.lasc.edu/aso/](http://www.lasc.edu/aso/)

Student Services Building 118

323-241-5253

323-241-5289 (fax)

The Associated Students Organization (ASO) of Los Angeles Southwest College is the authorized representative organization for the Student Body, established according to District BR9100 and Education Code Section 76060. The ASO has the responsibility of encouraging students to participate in the governance of the college in matters that have or will have a significant effect on students as identified by Title V regulation ss51023.7.

The ASO is governed, directed and regulated by its Student Council, which is comprised of up to 21 voting members, each charged with upholding the ASO constitution and by-laws. Regular meetings follow the strictures of the Brown Act and parliamentary procedure as defined by Robert's Rules of Order. Five members of the council are executive officers who are voted into office annually by the officially enrolled student body. Activities, including publications, assemblies, awards, holiday and historical recognition, co-curricular and extra-curricular, are sponsored or, in collaboration with other organizations, co-sponsored by the ASO.

All college clubs are affiliated with and chartered by the ASO; therefore, membership in the ASO is a prerequisite of membership in any other club.

Membership in the ASO is voluntary; however, the organization relies primarily on membership fees to function, and participation enables the optimal performance of the organization. The fee per semester is \$7.00 and \$3.00 for the Summer session and Winter intersessions. In case of withdrawal from the College, the student receives a refund of their membership fee according to the Schedule of Classes (and must surrender their ID card).

### ASSOCIATED STUDENTS ORGANIZATION (ASO): An Overview

The ASO General Council represents students in the shared governance process. The ASO emphasizes student leadership and self-governance to enable students to develop and express initiative in terms of the common good. Governed by the Executive Council, the Associated Student Organization conducts activities on behalf of the students. The General Council represents the student body's interests at the college, district, regional, state, and federal levels. On behalf of the Vice Presidents of Student Services, the ASO Advisor oversees the Associated Student organization Executive Council, Finance Committee, and Inter-Club Council.

In accordance with the policies of the Board of Trustees, the Executive Council and the Finance Committee actively participate in the management of the business affairs of ASO. A \$7 student activity fee supports enrichment programs and student events on campus. Board of Trustees rules govern the collection, deposit and expenditure of funds, and all records are subject to annual audit by the Board of Trustees.

1. LACCD Administrative Regulation E-22 (Eligibility for Student Association Officers) pertains to the following standards:

Note: The following standards governing candidate and officer (as defined by the ASO constitution and bylaws) eligibility for appointed and elected Associated Student Organization (ASO) officers must be met:

- a. The candidate or officer must be a currently paid member of the ASO at the college where the election is being held and have successfully completed no more than 80



- degree-applicable units in LACCD.
- b. The candidate may seek only one campus office within LACCD.
  - c. The candidate or officer must have and maintain a cumulative and current GPA of at least 2.0 in units completed at all the colleges in the District during the semesters in which the student government office is applied for and held. Current means the most recently completed semester or session. The ASO Constitution may not set a higher GPA requirement.
  - d. The candidate or officer must not be on academic or progress probation, as defined by LACCD Board Rule 8200.10.
  - e. At the time of election, or appointment, and throughout the term of office, the candidate or officer must be actively enrolled in and must successfully complete a minimum of five (5) units per semester. The ASO Constitution may not set a higher unit requirement. Units in which a student receives an Incomplete (INC) will not be counted in determining the number of units completed. Students falling below this requirement will automatically forfeit their office. Students who forfeit office for failing to meet this unit requirement will not be reinstated if INC grades are converted to letter grades and units are awarded for those courses. Candidates may be enrolled in more than one college in the District, but the candidate must be currently enrolled in a minimum of five (5) units at the college where the candidate is seeking office. Officers must maintain that enrollment at the college where the office is held.
  - f. Exceptions on the maximum unit requirement in Section 1a of this regulation may be made for students enrolled in a college degree, certificate or transfer program where the combination of program requirements and prerequisites may result in the student exceeding the 80 degree-applicable unit limit. Exceptions will be decided by the College President based upon recommendations made by the Chief Student Services Officer. In order to be considered for an exemption, a student who exceeds the requisite 80 degree- applicable unit maximum must satisfy at least one of the following conditions:
    - i. The requirements of the student's declared associate degree major, certificate and/or transfer objective, as specified in the college catalog, caused the student to enroll in courses that exceeded the 80 degree applicable unit maximum.
    - ii. Program prerequisites, as specified in the college catalog, caused the student to exceed the 80 degree- applicable unit maximum.
2. A candidate or officer is ineligible for ASO office:
    - a. If he/she has served more than four (4) semesters in any one (1) or more student government elected or appointed offices in the District.
    - b. If a candidate or officer, who exceeded the unit maximum in Section 1a of this regulation and was granted an exception fails to be enrolled in courses that are specifically required for his or her declared associate degree, certificate or transfer objective requirements, as specified in the college catalog.
  3. An officer may serve a fifth semester if eligible at the time of assuming office, with the approval of the college president or designee (e.g., has served three semesters and is a candidate for an office with a one year term).
  4. The Chief Student Services Officer and/or designee will verify a candidate or officer's eligibility. If the student should disagree with the findings of the Chief Student Services Officer and/or designee, he/she can appeal the decision through the student grievance procedures contained in LACCD Administrative Regulation E-55. Officers not adhering to the standards for office will be required to forfeit their positions.



5. Candidates or officers must comply with the minimum standards of the District Code of Conduct. Failure to comply will result in forfeiture of the position if an ASO officer is suspended for more than ten (10) days from one or more classes, activities, services, programs, or specific locations at any college in the Los Angeles Community College District, under LACCD disciplinary provisions (Board Rule, Chapter IX, Article VIII, Sections 9801-9806).
6. Any candidate or officer with a disability may request an accommodation for the requirements of section I (E):
  - a. The approval of the accommodation for candidates with a disability will be made in individual instances on a case-by-case basis by the Chief Student Services Officer in consultation with the college Compliance Officer and/or the Director of Disabled Students Programs and Services (DSP&S) in compliance with Section 504 of the Rehabilitation Act, and Title II of the Americans with Disabilities Act, as appropriate.
  - b. Qualification for an accommodation will be based on the impact of the disability on the candidate's/ officer's ability to take six units. However, a candidate or officer must be enrolled in a minimum of five units throughout his/her term in accordance with Education Code section 76071.
  - c. Procedures for requesting an accommodation under E-22:
    - i. Candidates/officers must complete a written request form for accommodation available in the college's Student Services Office, and return it to the Chief Student Services Officer.
    - ii. Each candidate or officer must present written documentation verifying the disability. Acceptable documentation includes, but is not limited to, written notice from the college DSP&S office or a certified or licensed professional, such as a doctor, psychologist, rehabilitation counselor, occupational or physical therapist.
7. Students enrolled in college credit and/or noncredit courses are eligible to vote at the college of attendance. Enrollment in Community Services classes does not meet this requirement.

#### Student Trustee Election Procedure

The Los Angeles Community College District conducts an election annually. Each student in the District has an opportunity to be involved in the process of selecting a student representative to the Los Angeles Community College District Board of Trustees.

### CAMPUS CLUBS AND ORGANIZATIONS

Believing that students will enrich their college experience by participation in extracurricular activities, LASC is proud of its active club program. Support for club programs comes from the Inter-Club Council, composed of a representative from each campus club, and chaired by the vice president of the ASO. In conforming to the California Education Code, the only recognized clubs are those chartered by the ASO. Thus, the college assumes no responsibility for activities of uncharted groups, including off-campus social organizations that consist of students or former students. State law prohibits membership in secret organizations.

Membership in any college club and/or organization requires primary membership in the Associated Students Organization.

#### Student Representation Fee

During the Associated Student Organization (ASO) Elections in April 17th and 18th 2012, Los Angeles Southwest College students passed the Representation Fee of \$1.00 per semester. Education Code section 76060.5 allows the ASO to conduct an election to



establish a student representation fee of one dollar (\$1.00) per semester. The fee will support governmental affairs representatives who will state their positions and viewpoints before city, county, district governments, and offices and agencies of the state government. ASO plans to use these funds to send LASC students to the State Capitol in Sacramento to advocate on behalf of all students for more funding and initiatives that increase student success. These funds will also be used for advocacy training for students.

- Honorary Clubs: Recognize and encourage outstanding achievement in scholarship and provide opportunities for developing leadership ability.
- Service Clubs: Recognize and honor students for outstanding achievement in citizenship and service to the College and provide opportunities for students to plan and execute programs of meaningful service to the college community.
- Departmental Clubs: Stimulate interest in activities related to courses and curriculum, encourage high standards of performance in academic work, provide experiences to complement classroom activities, and provide opportunities for service and leadership in areas related to course work.
- Special Interest Clubs: Provide opportunities for students with mutual interests to organize for the purpose of investigating, developing, or expanding their common concerns.

## ASO CLUBS

### How to Start a Student Club/Organization

Student clubs and organizations contribute to the development of the student and enrich campus life. In accordance with district and college policies, all campus clubs must be formally chartered by the Associated Student Organization (ASO).

Since the premise of a club is a social organization with a shared interest, the ASO Club Codes require a minimum of eight students who are paid ASO members and one advisor for a club to be established. The advisor must be a regular college employee. After being chartered in the fall, a club can renew its charter for the spring term by again verifying that it has at least five active ASO members and an advisor. Each club must re-charter each year.

Student Club Chartering Applications are made available at the beginning of each semester in the ASO Office, SSB 118 or on-line at [http://www.lasc.edu/aso/campus\\_clubs.html](http://www.lasc.edu/aso/campus_clubs.html).

The charter application includes the following information:

- Charter Application and Club Data Form
- Responsibility Club Advisor Form
- Sample Constitution
- Roster of Club Members (names, signatures, ID #'s of at least eight LASC students that provided copies of their fee receipts as proof of paid ASO fees)

The completed charter application must be turned in to the ASO Office. Don't wait too long to start a club; otherwise, student membership and ability to request space on campus for activities are negatively affected. Ideally, the chartering application should be submitted by the third or fourth week of classes.

Dr. Ralph Davis or LASC's ASO President is available to help guide you through the chartering process and role of advisor. Contact Dr. Davis if you have any questions at 323-241-5261 or [davisrw@lasc.edu](mailto:davisrw@lasc.edu).

#### CHARTERED CLUBS:

- Lesbian, Gay, Bisexual, Transgender, Intersex, Muxe, Pansexual, Allies, Queer (LGBT-IMPAQ) Club. Read the mission of LGBT-IMPAQ (English) (Spanish)
- Future Nurses of America
- Campus Connection
- The Single Parent Connection
- National Society of Collegiate Scholars (NSCS)
- The LASC Entrepreneur Club
- Student Ambassadors
- Phi Theta Kappa (Beta Pi Omega Chapter)
- LASC Village People
- Anthropology Club
- Urban Teacher Fellowship
- Making A Difference in Education (MADE formerly AFT Club)
- Black Student Union
- Hip Hop Congress
- International Culture Club
- Student Against Alcohol and Drug Addiction (SADDA)
- Toastmasters

#### HEALTH CENTER

[www.lasc.edu/students/healthcenter.html](http://www.lasc.edu/students/healthcenter.html)

Student Services Building (SSB), Room 115  
323-241-5252

A variety of health services are available in the Student Health Center, including basic first aid, physical exams, sick visits, STD testing, and personal counseling. Students can call for an appointment, and walk-ins are also accepted. For more details regarding hours of operation, services offered and scheduling an appointment, visit the center's website. There is a health fee of \$11 in the Fall and Spring semesters and \$8 for the Summer and Winter sessions.

In case of a life-threatening emergency, call 911.

#### PHI THETA KAPPA INTERNATIONAL HONOR SOCIETY

##### **Beta Pi Omega**

[www.lasc.edu/crt/phithetakappa.html](http://www.lasc.edu/crt/phithetakappa.html)

323-241-5392

Los Angeles Southwest College has a chapter of Phi Theta Kappa International Honor Society of the Two-Year College. The name of LASC's chapter is Beta Pi Omega. The purpose of Beta Pi Omega is to recognize and encourage scholarship among LASC students. To achieve this purpose, Beta Pi Omega provides an opportunity for the development of leadership and service for an intellectual climate for exchange of ideas and ideals, for lively fellowship for scholars, and for stimulation of interest in continuing academic excellence.

Each candidate for membership must have completed one semester or equivalent term hours of associate degree course work (12 credit hours) with a cumulative Grade Point Average of





3.4 or above on a 4.0 scale, adhere to the school conduct code, and possess recognized qualities of leadership. Both full-time (12 units) and part-time students (six units) at Los Angeles Southwest College are eligible for Beta Pi Omega.

Membership applications are available in the TRIO Scholars Office, which is located on the second floor of the Student Services Building, Room 229. After induction to the chapter, members must simply maintain a GPA of 3.0 to remain active members.

As a member of Beta Pi Omega, academic excellence is recognized with the Golden Key Membership Pin, membership certificate and identification card, access to over \$3 million in scholarship opportunities, free college visitations, mentoring opportunities, notation of membership on diploma and transcripts and the privilege of wearing regalia at graduation that sets students apart as a member of Phi Theta Kappa-Beta Pi Omega.

#### INTERNATIONAL STUDENTS SERVICES

[www.lasc.edu/students/international/prospective.html](http://www.lasc.edu/students/international/prospective.html)

Student Services Building (SSB), Room 209  
323-241-5278

Darren Grosch, International Student Services Officer

The International Student Services (ISS) office at Los Angeles Southwest College provides information and support services to international students as well as coordinating study opportunities to LASC students and faculty. International students interested in studying at LASC's campus may receive help with their application and visa procurement, while current on-campus international students receive support through an array of on-site student services. The ISS office connects LASC's student body to the global community through on-campus activities as well as study abroad courses.

#### OUTREACH & RECRUITMENT

[www.lasc.edu/students/outreach.html](http://www.lasc.edu/students/outreach.html)

Student Services Building (SSB), Room 209  
323-241-5325

Johnel Barron, Student Recruiter

The Office of Outreach and Recruitment provides information to potential students, K-12 partners, and the community at large about the various programs and services offered at LASC. Outreach and Recruitment staff members conduct presentations, workshops, events, and tours regarding LASC programs and resources, as well as assist high school counselors and community workers with disseminating information about LASC programs and the application process.

#### TRIO PROGRAMS

##### EDUCATIONAL TALENT SEARCH

[www.lasc.edu/trioets/trioets.html](http://www.lasc.edu/trioets/trioets.html)

Student Services Building (SSB)  
323-242-5523 Phone  
323-242-5524 Fax

Sidney Cosby, Program Specialist  
Brandy Quarles, Office Assistant

Educational Talent Search (ETS) is a federal TRIO program 100% funded by the U.S. Department of Education. ETS is a pre-college program, which serves 600 participants who maybe low-income or potential first-generation college student, who reside in the area or attends a target school:

### High Schools

Washington Preparatory High School  
Duke High School

### Middle Schools

Animo Phillis Wheatley  
Animo Western  
Bret Harte

ETS provides each participant with services that will allow them to be prepared for college, to better understand and pursue educational opportunities and options to be competitive in their quest for post-secondary education and beyond.

In addition, to academic advisement, participants receive information on Science, Technology, Engineering, Agriculture, Financial Literacy, College and Financial Aid application process, College Tours, Cultural Outings, Tutoring, Workshops, Leadership and Mentoring program(s).

All services are free of charge.

**Facebook:** [www.facebook.com/ETSLASC](http://www.facebook.com/ETSLASC)

**Instagram:** [www.instagram.com/talent\\_search\\_lasc/](http://www.instagram.com/talent_search_lasc/)

### UPWARD BOUND

[www.lasc.edu/students/upwardbound/ubhome.html](http://www.lasc.edu/students/upwardbound/ubhome.html)

Student Services Building (SSB), Room 208  
323-241-5378

Upward Bound (UBP) is a federal TRIO program funded by the U.S. Department of Education. Nationally, Upward Bound originated from Title IV of the Higher Education Act of 1965, along with Educational Talent Search and Student Support Services. The mission of the Upward Bound program at Los Angeles Southwest College is to select and prepare low-income and first generation high school students in the college's target area for persistence through secondary education and matriculation into institutions of higher education. Instruction in core academic areas, cultural field trips, tutoring, SAT preparation courses, visits to colleges and universities, and mentoring are some of the approaches the Upward Bound Program uses to accomplish its goals. All services are free for eligible student participants.

### SCHOLARS

[www.lasc.edu/crt/index.html](http://www.lasc.edu/crt/index.html)

Student Services Building (SSB), Room 228  
323-241-5392  
Shakeeba Warren, SFP Program Technician

The TRIO Scholars Program is a Student Support Services program funded by the U.S. Department of Education. At Los Angeles Southwest College, the TRIO Scholars program is designed to help students graduate and transfer to a four-year college or university. The services provided by the program are counseling and academic advisement, assistance with transfer college applications, career advisement, Supplemental Instruction for Math and English, college tours and field trips, financial literacy workshops, and transfer success workshops. College representatives from the University of California system, the California State University system, and private colleges provide regular campus visits to give up-to-date information to the program's participants. All students interested in and planning to transfer are encouraged to become a part of the TRIO Scholars program. Program participants must



meet the eligibility criteria: first-generation college student, low-income student, or disabled student.

SCIENCE, TECHNOLOGY, ENGINEERING & MATH—S.T.E.M.

[www.lasc.edu/students/triostem/triostem.html](http://www.lasc.edu/students/triostem/triostem.html)

Student Services Building (SSB), Room 229

323-241-5392

Dr. Angelita Salas, Counselor, Program Coordinator

The STEM Scholars program is a TRIO/Student Support Services program at Los Angeles Southwest College, funded by the U.S. Department of Education. The STEM Scholars program is designed to assist students with preparing for graduation and transferring to a four-year college or university in a science, technology, engineering, and mathematics major or in the allied health fields (Nursing).

Services for STEM Scholars include comprehensive STEM specific counseling, supplemental instruction and tutoring in math and science, college success workshops, career exploration workshops collaboration with faculty in science and mathematics, college application workshops, assistance with financial aid applications and financial literacy, summer internship opportunities, college tours and field trips.

In order to qualify for the STEM program, students must meet certain eligibility criteria: first-generation college student, low-income student, or student with disabilities. A counselor is available to meet you to discuss how the STEM Program can assist you. For more information, email [lasctriostem@lasc.edu](mailto:lasctriostem@lasc.edu).

## COUNSELING

Student Services Building, Room 227

323-241-5200

[www.lasc.edu/students/counseling](http://www.lasc.edu/students/counseling)

Our friendly counselors are available to assist you with meeting your educational, career, and personal goals. Whether transferring to a four-year university, earning an associate degree or career certificate, we are always available to help our students. Our counselors are available by appointment or walk-ins.

### WHEN TO SEE A COUNSELOR

1. Once the Assessment process is completed, a new student to LASC must meet with a Counselor for an abbreviated Student Educational Plan (SEP).
2. Before semester registration begins meet with a Counselor.
3. Schedule an appointment approximately one month into the current semester to complete an SEP to plan for on time graduation and transfer readiness.
4. While in their last semester of classes students will meet with a Counselor to file the petition for graduation and certification for transfer.

### Faculty

Rose Calderon  
Counselor, General

Ralph Davis  
Counselor, PASSAGE Coordinator

Lisa D. Ford  
Counselor, Transfer

Christina I. Gonzalez  
Counselor, SSSP

Ron Haynes  
Counselor, CalWORKs

Janice E. Lee  
Counselor, General

Kimberly McBride  
Counselor, SLO Coordinator

Erica Miller  
Counselor, Trio Scholars

Daniel Ortega  
Counselor, Puente/ EOPS

Blanca Rodriguez  
Counselor, General

Angelita F. Salas  
Counselor, TRiO STEM

Roxanna Sanchez  
Counselor, DSPS

Alexis J. Tucker  
Counselor, General

Michelle Williams  
Counselor, EOPS Director

Katrin Wilson  
Counselor, Articulation Officer





## Adjunct Counselors

Arauza, Angelica.....	EOPS
Cabrera, Edith.....	BTS
Campos, Lina .....	CaWORKS
Corona, Gabriela .....	SSSP
Diaz, Sandy .....	BTS
Graves, Steve.....	CARE
Hawkins, Floy .....	Community Services
Jarrett, Wendy .....	General
Johnson, Kenya .....	General
Lara, Olga .....	DSPS
Moss, Yvette .....	Child Dev
Reynoso, Carla .....	DSPS

Robinson, Brandy A.....	FYE
Nishiyama, Tara.....	SSSP
Thomas-Green, Rachel ....	CARE
Torres, Norma.....	Nursing
Tucker, Yvette.....	SSSP
Williams, Matthew.....	General
Williams, Rhea.....	General/S&BS
Wilson, Montely .....	PASSAGE

## Staff

Buggage, C. Rhuné, .. Student Services Aide,  
General Counseling

Counselors are the Academic Faculty of the Student Services Department.

The function of the Counseling Department is to provide a bridge between the Student Services and Academic areas. It is our purpose to assist our diverse population's progress toward their intended academic goals. It is also our purpose to provide information that will lead to career opportunities, as well as obtaining productive life-skills. As the primary point of contact for academic planning, counselors identify resources for new, returning and continuing student success; all within an environment that is professional, caring, and competent.

Within Student Services, Counseling functions include:

Assessment (SSSP) – Orientation and Assessment; Probation Counseling;

Matriculation – transcript evaluation, academic planning, as well as GE Certification, Degree Petitions and Program Certification;

Financial Assistance – appeals, Education Goals, Student Educational Plan agreements, Consortium agreements; Examine and adapt State and Federal regulatory changes that impact programming and Student Success.

Counselors are available in many areas and programs that aid in Student Success.

BTS – Bridges to Success

CARE – Cooperative Agencies Resources for Education

CaWORKs – California Work Opportunities and Responsibility to Kids

Career & Transfer Center

Child Development

DSPS – Disabled Students Programs and Services

EOPS – Extended Opportunities Programs and Services

FYE – First Year Experience

GAIN – Greater Avenues to INdependence Nursing

PASSAGE

PUENTE

SSSP – Student Success & Support Program



TRiO Scholars and TRiO STEM  
Veteran Center

In the Academic area, Counselors have additional functions:

**ARTICULATION** – Work in concert with the Senate, Curriculum and Academic Departments to certify new courses and update current courses for programs, certificate and degrees; transferability of course agreements between community colleges, state and private colleges and universities.

**INSTRUCTION** - Counselors also instruct Counseling courses.

The Counseling Department believes that students should take time early in their college life for personal development; learning to make comprehensive plans to meet their interests, values, and abilities, improve their time-management skills and adopt other behaviors key to their success in college and beyond.

Counseling courses provide students with an understanding of the academic process, also how to define personal and career goals. These courses introduce the student to Los Angeles Southwest College's programs and services, are degree applicable and transferable.

The Counseling faculty is available throughout the calendar year to assist students in defining their objectives, planning a course of action, and continuing on the right path toward their educational goals. For success in college, students should see a counselor at least once each semester.

### COUNSELING COURSES

Course #	Description
6	Career Planning for Students With Disabilities (1) CSU
17	College Survival Skills Development (1) CSU
20	Post-Secondary Education: The Scope of Career Planning (3) CSU
40	College Success Seminar (3) CSU

### CALWORKS

Student Services Building (SSB) 217

323-241-5477 Office

323-241-5488 Fax

[http://www.lasc.edu/students/gain-calworks/gain\\_calworks.html](http://www.lasc.edu/students/gain-calworks/gain_calworks.html)

Blanca Barajas, Director

Ronald Haynes, Counselor

Lina Campos, Adjunct Counselor

Jerome Robertson, SFP Program Technician

The CalWORKs Program is a California Community College program serving CalWORKs



(TANF recipients) students and their families by providing a myriad of educational, career and work opportunities via coordinated student services on campus and collaborative efforts with the local county department of social services and other community partners off campus. Our goal is to empower our CalWORKs students to complete their educational goals, obtain employment, and successfully transition into the workforce thereby allowing them to become self-sufficient.

In addition, the CalWORKs Program offers the male empowerment group, *The GAME* (Grown As Man Experience) which is coordinated and facilitated by our male CalWORKs staff. The goal of the GAME is to provide the tools outside of the classroom for our male students to reach their full potential in an atmosphere of brotherhood.

The CalWORKs program provides the following intensive student services to assist its students achieve their educational and career goals:

- Priority registration
- Orientation and assessment
- Academic, CalWORKs and personal counseling
- Development of a Student Educational Plan
- On- and off-campus work study
- Assistance with job placement
- Books and supplies
- Job readiness workshops
- Referrals to community resources
- Instructional support, including tutoring
- Completion of County program documents
- Assistance with child care
- Student support groups

#### EXTENDED OPPORTUNITY PROGRAM AND SERVICES (EOPS)

Students Services Building (SSB) Room 218

Phone: 323-241-5484

Fax: 323-241-5304

<http://www.lasc.edu/students/eops.html>

Michelle Williams, Program Director

Daniel Ortega, Counselor/Puente Coordinator

Angelica Arauza, Adjunct CAYFES Counselor

LaRon Armstead, Adjunct Counselor

Steve Graves, Adjunct Counselor

Rachelle Green, Adjunct Counselor/CARE Coordinator

Linda Fox, Sr. Office Assistant

Extended Opportunity Program and Services (EOPS) provides support services that are “over and above” those services offered to the general community college population. EOPS encourages the retention and transfer of low-income students challenged by language, social, economic, and educational disadvantages so that these students will achieve their educational goals.

In order to be considered for EOPS, you must meet all of the following eligibility criteria: California resident; enrolled full-time (12 units) when accepted by EOPS; qualify to receive a Board of Governors Waiver (BOGW); completed less than 50 cumulative units at all colleges or universities attended; completed or currently enrolled in a Personal Development course.

You must also meet one of the following criteria: did not qualify for enrollment in the minimum level English or Mathematics course required for an associate degree; did not graduate from high school or obtain the General Education Diploma (GED); graduated high school with a grade point average below 2.0; previously enrolled in remedial education courses; first generation college student; member of an underrepresented group; parent(s) are non-native English speakers; emancipated foster youth status.

Once accepted to the program you are eligible to receive the following services:

- Enhanced tutoring
- Access to state-of-the-art computer lab with Internet access
- Counseling and advisement
- Priority registration
- Instructional support
- Book services (Students must provide verification of first class attendance prior to their book voucher being processed)
- Educational supplies and materials

If you are an AB540 student and you are interested in applying for the EOPS program, please visit the EOPS/CARE office and speak to the Director regarding qualifications.

#### COOPERATING AGENCIES FOSTER YOUTH EDUCATIONAL SUPPORT (CAFYES)

CAFYES is an expansion of EOPS – Intended to encourage the enrollment, retention, and transfer of current and foster youth at Los Angeles Southwest College. Aims at providing “over and above” support and services by establishing an educational program that assists students in several areas, including priority registration, counseling, tutoring assistance, books and supplies, career guidance, student success workshops, housing assistance, and mental health referrals. Eligible students are those whose dependency was established by the court on or after the youths 16th birthday, no older than 25 years of age at the beginning of the academic year, be enrolled in at least 9 units, or provide Court Verification Letter.

In Addition, CAFYES alone can provide services to students who are no longer eligible for EOPS (e.g. exceeded the 6 semester/70 unit cap). CAFYES shall cooperate with local county child welfare departments, county probation departments, local educational opportunity and services programs, and the community college district. CAFYES services are coordinated with and do not supplant other services. CAFYES support and services are leveraged by other sources, e.g. Extended Foster Care and CalFresh, and pay last.

#### FRESHMAN YEAR EXPERIENCE (FYE)

Student Services Building (SSB), Room 228

323-241- 5228

<http://www.lasc.edu/students/fye/fye.html>

FYE’s goals are to cultivate academic achievement and interpersonal competencies and to lay the foundation for lifelong success. FYE serves incoming first-time college students and implements the following programs and services:

- Extended Orientation
- Summer Bridge
- Learning Communities (linked courses, intrusive counseling, mentoring, and service learning)
- Supplemental Academic Assistance (tutoring and supplemental instructions)
- Faculty Professional Development





All FYE participants work with the FYE coordinator/counselor to develop their individualized educational plan and throughout the academic year, academic skills workshops will be provided all students will continue to receive individualized counseling, and their academic progress will be monitored.

### PASSAGE PROGRAM

The Passage Program encompasses academic and student support services aimed at increasing the success rate of male student participants at Los Angeles Southwest College (LASC). The program focuses on empowering and equipping male students with the tools for academic success. The Passage Program works in conjunction with campus offices such as Counseling, Outreach and Recruitment, Assessment and Matriculation, and other campus resources in effort to inform the students of the Passage Program. To support the efforts of male students at Los Angeles Southwest College, the Passage Program offers:

- Passage Program supports student in defining and achieving their educational goal(s).
- Passage Program creates meaningful experience that promotes self-awareness, personal growth and student success.
- Passage Program is an opportunity for male students to connect and network with other men desiring success.
- Passage Program assists our students in preparation for transfer to a variety of four-year colleges.
- Passage program is an opportunity for male students to become self-sufficient, capable students, leaders, and responsible citizens.

In order to address the changing educational needs of LASC students, the Passage Program encompasses academic and student support services working to increase the success rate of male student participants. The Passage Program is comprised of counseling, a student led club, computer access and tutoring/supplemental instruction and other academic enrichment activities. The Passage Program also provides intrusive counseling to increase student persistence while utilizing technology as a vehicle to communicate information to students participating in the program. Additionally, the program provides workshops and support services that focus on the holistic development of the students.

### PUENTE PROGRAM

323-241-5201 (Puente Counselor)

323-241-5250 (Puente Instructor)

[http://www.lasc.edu/students/counseling/puente\\_program.html](http://www.lasc.edu/students/counseling/puente_program.html)

Puente is a federally recognized statewide program, subject to the visions of the University of California's Chancellor's Office and the Puente statewide office. The Puente Program is a joint venture between the English and Counseling departments at LASC, and incorporates goals and plans from each department. The goal of the program is to help underrepresented students at two-year institutions successfully transfer to four-year colleges by providing them with a counselor and English instructor who work in tandem to tailor educational plans and writing skills in preparation for baccalaureate programs.

Phase 1 and Phase 2 of Puente take place in the fall and spring semesters of each academic year. Phase 1 students participate in English 28 (one course below university transfer-level) and Personal Development 17. Phase 2 students enroll in English 101 and Personal Development 20. Both English courses follow the English Department course outlines and incorporate readings that reflect the Black and Latino/a experience. Phase 3 students continue to meet with their counselor as they complete their transfer requirements and apply to four-year universities. The English instructors and counselors also oversee community

involvement and social justice-themed activities that students participate in within the community.

What Will I Do in the Puente Program?

As a student of this program:

- You take a year of accelerated English classes with a curricular focus on Latino Literature and experience.
- You are matched with a professional from the community who will share their knowledge and experience with you.
- You experience cultural activities, assist your community and develop leadership skills.
- You meet frequently with your Puente counselor to develop and monitor an educational study plan and for personal/career counseling until you are ready to transfer.
- You take educational field trips to universities each year and attend an annual statewide Puente Student Conference.

## DISABILITY SERVICES

(Disabled Students Program and Services)

Student Services Building (SSB) 117

323-241-5480

TDD: 323-241-5482

<http://www.lasc.edu/dsps/index.html>

### General Information

Southwest assures accessibility of programs and activities to students with disabilities. The college's mission is to provide support services which contribute to student success. The Disabled Students Program and Services (DSP&S) has been established to provide supportive services to students with physical, psychological, and learning disabilities. The program objective is to assist students with disabilities in meeting their educational and vocational goals.

Qualifying student may receive the following services: specialized tutoring, test-taking assistance, sign language interpreters and real-time captionists, Braille and non-Braille transcription services, and disability-related specialized counseling services. Other services include registration assistance, priority enrollment and a variety of assistive computer technologies which promote equal access to college instructional programs and activities for students with disabilities.

### Medical Parking

Any vehicle parked in a space designated for "disabled only" must display an authorized disabled placard from the Department of Motor Vehicles and an LASC parking permit. Students should check the Campus Parking Regulations section in the catalog regarding additional parking information.



## LIBRARY (Founder's Library)

Cox Building, 2<sup>nd</sup> Floor

(322) 241-5235

[libguides.lasc.edu/lasc\\_library](http://libguides.lasc.edu/lasc_library)

### Welcome to the LASC Founder's Library

The Founders Library is located on the 2nd, 3rd and 4th floor of the Cox Building. The Library offers high-speed copiers, study carrels, computers with internet access, a reading room and five group study areas. Its collection contains print and electronic books, and newspapers.

The Library also has many class textbooks on Reserve at the library Circulation desk for student use in the library. All currently registered students are eligible to check out library materials by showing their LASC student ID card. Computers are available in the library for student research, word processing and printing. Both black/white and color copiers/printers are available for student use in the library. Students should consider the LASC library their first and best source of learning materials.

With remote access via the internet to the Library book catalog, specialized subscription electronic databases, and an electronic book library of thousands of titles, the library provides a state-of-the-art library, 24 hours a day, seven days a week. Students can access all online library resources both on and off campus at no charge with the current password available in the library. Visit the library's web page for more information.

The Library is located on the 2nd, 3rd, and 4th floor of the Cox Building.

### Faculty

Linda Brady (2005)

Librarian

Double B.A., California Baptist University

M.L.I.S., San Jose State University

Timothy Ream (2015)

Librarian

B.A., University of California, Los Angeles

M.L.I.S., San Jose State University

Deborah Farber (2016)

Assistant Professor

B.A., California Lutheran University

M.A., San Jose State University

Parisa Samaie (2016)

Assistant Professor

B. A. California State University, Long Beach

M.L.I.S., University of California, Los Angeles

### Adjunct Faculty

Cobbs, H., ..... Librarian

Lindsay, G., ..... Librarian

McCollum, P.H., ..... Librarian

Zandieh, S., ..... Librarian

### Staff

Bell, Felicia ..... Library Technician

Casey, Kevin P. .... Library Technician

Garcia, Charles ..... Library Technician

Gomez, Domingo ..... Library Technician

## STUDENT RESOURCES

LASC offers a wide range of programs that promote academic, career, and leadership growth. Recognizing that the needs and interests of our students vary, the academic division as well as in the Student Services offices offer varied support services to help our students succeed. Student resources at LASC that include workshops, counseling services, tutoring, library resources, career training, as well as health and safety services.

### English Writing Center (EWC)

<http://www.lasc.edu/students/ewc.html>

The English Writing Center (EWC) is a dedicated center, housing the required laboratory component of LASC's English 21 and 28 course curricula. EWC instructors and tutors assist students in both the academic and technical aspects of completing online lab assignments. Established in spring 2009, the EWC has evolved to offer multiple services to all students in the English program and to LASC students writing across the curriculum, including individual and group tutoring, workshops, supplemental instruction, and promotion of special events on campus.

### International Student Services

<http://www.lasc.edu/students/international/prospective.html>

The International Student Services (ISS) office at Los Angeles Southwest College provides information and support services to international students, as well as coordinating study opportunities to LASC students and faculty. International students interested in studying at LASC's campus may receive help with their application and visa procurement, while current on-campus international students receive support through an array of on-site student services. The ISS office connects LASC's student body to the global community through on-campus activities, as well as study abroad courses.

### Student Success Center (SSC)

<http://www.lasc.edu/lascenter/index.html>

The Student Success Center focuses on multidisciplinary success. As a student-centered instructional support provider, we are committed to partner with all Los Angeles Southwest College students to make their transition to college a success. Our qualified and friendly staff comprised of a dedicated coordinator, adjunct faculty, student tutors, program assistants, and community volunteers use innovative methods to assist students in their academic, personal, and career development. By working in one-on-one and small group settings, students can take advantage of our supplemental learning activities such as peer tutoring, directed learning activities, success seminars, web-based resources including tutoring and workshops, audio and video programs, study areas, computer services, and assessments for our contract education programs.

### Hours for SSC

Since our hours fluctuate to meet students' needs each semester, check the SSC website [http://www.lasc.edu/student\\_success\\_center/student\\_successindex.html](http://www.lasc.edu/student_success_center/student_successindex.html) for current information. The SSC encourages students to schedule appointments through our online scheduling system, by calling (323) 241-5455, or by walking in to speak with a staff member. We also welcome students to drop in for services – so just come on by.

### Are You Interested in Becoming a Tutor?

To qualify as a tutor, students must demonstrate sufficiency in their subject of interest by successfully completing at least one course in the subject of concentration with a "B" or higher. All tutors must receive a faculty recommendation and the department chair's written approval, as well as maintain at least a 2.5 GPA prior to and during their time of employment. Additionally, to serve as a tutor, students must be enrolled in at least six units on campus or



at a four-year accredited college or university. Note: Students may not work as a tutor while on academic probation or progress probation. To receive an application, come by the SSC to discuss the opportunity. We would love to have you join our dynamic team.

## VETERANS SERVICES

Student Service Building (SSB), Room 207  
323-241-5277

<http://www.lasc.edu/students/veteranservices.html>

Yvette Tucker, Veterans Representative

The Veterans Resource Center (VRC) provides veterans and active military personnel with resources that will promote a smooth transition from military life to a successful campus life. Persons planning to attend Los Angeles Southwest College under the Montgomery GI Bill (MGIB) should schedule an appointment with the Veterans Representative, Yvette Tucker, in SSB Room 207 as soon as possible. The documentation listed below is required to bring to the Veterans Representative upon enrollment. These include: DD 214 and/or DD2384, Form 22-1905, letter of eligibility, and a comprehensive student educational plan. Several weeks are needed for the Veterans Administration to process subsistence payment applications. An early start with a counselor is advisable.

Los Angeles Southwest College will grant six (6) elective units of credit for military service if the person has (a) spent at least one year in active service, and (b) has not received a dishonorable discharge. Elective credits will be granted when requested along with the petition for graduation. These units will not satisfy physical education, health education, or subject area requirements. A copy of the DD 214 must be on file in order to receive credit.

It should be noted that all veterans receiving subsistence absolutely must demonstrate adequate academic progress. This is a major requirement by the Veterans Administration to continue receiving payments benefits.

**Attendance Regulations** - Each student is required to attend all meetings of every class in which he/she is registered. A student who is excessively absent may be dropped by the instructor when his/her hours of absence equal the number of hours the class meets per week, regardless of the reasons for the absences.

**Withdrawal** - It is the responsibility of the veteran to immediately inform the Veterans Representative of any reduction in unit load. The last day of a veteran's attendance in class must be reported immediately to the Veterans Administration to avoid overpayments.

An excessive number of "W" units may lead to progress probation or disqualification. This will ultimately lead to discontinuance of Montgomery GI education benefits.

**V.A. Certification** - In order for a veteran to be certified for attendance, two criteria must be met: the veteran must be officially registered, and he/she must be in good academic standing.

**Scholarship Requirements** - A student will be placed on academic and/or progress probation if any one of the following conditions occurs:

1. The student's overall grade point average falls below 2.0, or the student's grade point average in any semester is below 2.0;
2. The student transfers from another college with an overall grade point average under 2.0;
3. The total number of "W" units exceeds the number of units completed;
4. All students who fail to maintain a C (2.0) grade point average for the semester are on probation, and are subject to disqualification.

- **Program Planning for Veterans** - To be eligible for veterans' benefits, the veteran must select a major and choose courses from those listed under the major in the catalog. A

veteran may elect to choose a number of remedial courses offered by Los Angeles Southwest College to enhance his/her academic background. The remedial courses will give the student the necessary tools to do college level work. When a veteran chooses a remedial program, the units are not eligible for benefits. The units taken are also not transferable to a four-year college. For more information, visit the Counseling Office.

- **Graduation Unit Requirements** - A veteran who has received the required minimum units to obtain an Associate of Arts Degree (60 units) but needs additional units to graduate must have an overall evaluation of his/her complete records before he/she will be certified for benefit payments. The veteran must first go to the Counseling Office and then return with the evaluation sheet, properly signed by one of the LASC Counselors. From this evaluation, the Office of Veterans Affairs will certify only those classes that are deemed necessary for graduation.

## CAMPUS SAFETY & PARKING

### Deputy Sheriff's Services

[www.lasc.edu/about\\_lasc/Campus\\_Crime\\_Stats.html](http://www.lasc.edu/about_lasc/Campus_Crime_Stats.html)

Sheriff's Substation

323-241-5311

The Los Angeles County Deputy Sheriff's Department serves LASC. Sheriff's Deputies are sworn law enforcement officers under California Penal Code Section 830.1 and, in compliance with state law, meet the Peace Officer Standards and Training requirements mandatory for all California law enforcement officers. In addition, college deputies undergo training specially designed to meet the needs and problems of a contemporary college.

Deputy Sheriffs provide the campus population with patrol, traffic control, accident investigation, emergency first aid, and lost/found property service.

To contact the Sheriff's Deputies and report a problem or make an inquiry, students may call any of the following numbers: (323) 241-5311 or (323) 241-5269. From the Emergency Blue Phone locations within campus, you may press the red button to reach the College Sheriff's Station. No money is required and you will be immediately connected to the college police.

If there is an emergency and the Deputy Sheriffs are unavailable, call 911 for outside emergency response.

### Crime Statistics Disclosure & Annual Security Report

As required by the federal Jeanne Clery Disclosure of Campus Security Policy and Campus Crime Statistics Act ("Clery Act"), the college's Annual Security Report contains policy statements and crime statistics for the campus. The Annual Security Report includes statistics for the previous three years concerning certain reported crimes that occurred on campus, in off-campus buildings or property owned or controlled by the college, and on public property within or immediately adjacent to the college. The report also includes institutional policies concerning campus safety and security, such as policies on drug and alcohol use, crime prevention, the reporting of crimes, sexual assault, and emergency response and evacuation procedures.

You can obtain the college's Annual Security Report online at [http://www.lasc.edu/about\\_lasc/Campus\\_Crime\\_Stats.html](http://www.lasc.edu/about_lasc/Campus_Crime_Stats.html). You may also request a paper copy by contacting the Deputy Sheriff's Office or the Library.

Additional information may also be accessed at <http://www.lasdhq.org/stations/for2/comm-college/JeanneClery.html>



## Lost and Found

Lost and found is located in the Sheriff's substation.

## Campus Parking Regulations

Parking in areas marked "Parking by Permit Only" will be restricted to vehicles displaying a valid permit.

L.A. Southwest College Traffic Regulations for Student Parking: Permit and Citation Information *Authorization* Section 72247 of the California State Education Code Board Rules, Chapter II, Article II 2309

### *Permit and Fees*

1. The parking permit is a license to park a specific vehicle and is non-transferable. Purchase of a student-parking permit does not guarantee a parking space.
2. ASO preferred parking for \$27.00 per vehicle for fall and spring semesters (\$10 for summer), will allow a student to park in the student portion of all Lots.
3. General parking for \$20.00 per vehicle for fall and spring semester (\$13 for summer), will only allow a student to park in Lots 3 & 4.
4. Permits may be purchased through the Business Office (SSB 103).
5. Staff and Faculty permits may be obtained for those who qualify through the Deputy Sheriff's Office. An application must be completed for each permit. Permits are non-transferable. No permanent permits will be issued without Employee I.D. card and verification of employee's status. Bring your vehicle's plate or VIN number with you, as no permits may be issued without it.
6. Student/Visitors wishing to park on campus for short-term stays are welcome to purchase a day permit. Fees and parking areas for these all day permits are as follows:
  - a. \$2.00 Student/Visitor Parking Permits – valid in student portions of all lots.
  - b. \$2.00 Special Event permits are valid in all lots (unless otherwise directed by the Deputy Sheriffs).

These passes may be purchased in the Sheriff's Office.

Students are always required to have a parking permit, including when parking is free of charge.

## Refunds

1. Refund of parking fee will be granted only if the parking permit is returned in reusable condition or removed from the vehicle by Campus Police personnel. There will be no refund if the permit is lost or stolen. Refunds shall be granted according to the following schedule:
  - a. First two weeks of class = 100%
  - b. After two weeks = NO REFUND

Refunds are made in the Business Office (SSB 103), Student Service Building

2. Absolutely no refunds for ASO student parking fees or one day parking permits.

## Parking Regulations

A valid parking permit must be visibly displayed on any vehicle parking on campus, except in the 30-minute visitor parking area, which is monitored and cited.

1. All vehicles must be parked clearly within a designated parking stall.
2. All vehicles shall be parked heading into the parking stall.
3. “No Parking” signs must be observed.
4. Any vehicle parked in a space designated for “disabled only” must display an authorized disabled placard from the Department of Motor Vehicles and an LASC parking permit.
5. No vehicle shall be parked overnight on campus.
6. Any vehicle repeatedly in violation of parking regulations may be towed away at the owner’s expense.
7. No vehicle shall be parked between buildings on campus without expressed permission of the Deputy Sheriff’s Office; and those who do so will be cite and/or towed at owner’s expense.
8. Areas marked “RESERVED” located in Lot 1, are to be utilized by the President, Vice Presidents, and Deputy Sheriffs only; all others who park there are subject to be cited and/or towed at owners expense.

### Citations and Payment

1. Persons parking illegally on campus will receive a parking citation (\$30 - \$340), as authorized by Section 21113A of the California Vehicle Code.
2. Persons parking illegally in the Disabled Person’s parking area will be cited (\$340) by Section 22507.8b of the California Vehicle Code.
3. These citations will be payable through the Los Angeles Southwest College Parking Citation Services Center, and can be resolved in accordance with the Administrative Review Process. See “Parking Citation Complaint” below.
4. Consumers with citation disputes have 21 days only from the date of the citation for their complaint to be heard. Come in or call the Sheriff’s Office to obtain an Administrative Review form.

### Parking Citation Complaint

Consumers not in agreement with a parking citation have the right to contest the citation by filing an Administrative Review, a request for an Administrative Hearing, and, if necessary, a Municipal Traffic Court Appeal. Complaints must be filed within 21 days of citation or hearing results. Contact the Deputy Sheriffs Office for more information.

### Students Park at Their Own Risk

The Los Angeles Community College District is not responsible for students’ vehicles or their contents while parked on the campus.

## COMMUNITY RESOURCES

Members of the greater community have access to numerous resources and facilities at LASC, including non-credit classes, career training, and youth programs. In addition, members of the community may rent our athletic field, gym, lecture halls, and conference rooms along with other services. LASC offers learning opportunities, programs, resources, attractions, and facilities to meet the lifelong learning and cultural needs of our diverse community.





## COMMUNITY SERVICES

Student Services Building (SSB), Room 206  
323-241-5288

Joni Collins, Manager  
Janet Gordon, SFP Technician/ Foster and Kinship Care Education  
Debbie Jordan, SFP Technician  
[lasc.augusoft.net](http://lasc.augusoft.net)

Community Services is one function of the Community College. The Community Education Program at LASC offers a variety of non-traditional activities for the purpose of meeting the individual and community needs not served by the College degree or certificated programs. There are no transcripts or grades.

Offerings include educational, cultural and recreational activities as well as seminars and workshops. The Community Services programs for adults (18 and over) include short-term, non-credit activities in personal development and skill improvement. Special programs have been designed to meet the needs of youth (ages 6-17) in the skills improvement area, and activities are offered for enrichment in such areas as languages and performing arts; however, a small fee is charged for some activities. The Community Services Program establishes linkages with related college and community programs to supplement and coordinate with existing offerings.

### Foster/Kinship Care Education (FKCE)

Come to FKCE When You:

- Take care of a relative's child
- Think you would like to care for a child in the "foster system"
- Need to complete mandated state foster care education
- Care for another's child and want to improve your parenting skills

Because you make a difference, our job is to help you make that difference. Update your caregiving skills and knowledge at LASC's Foster/Kinship Care Education Program Department. For more information, contact us at (323) 241-5260.

### Independent Living Program (ILP) (YDS)

This program provides independent living skills training to Los Angeles foster youth, ages 16-18, through 18 area community colleges. DCFS Independent Living Program Coordinators refer foster youth to Para Los Ninos -ILP for the training. Para Los Ninos Outreach Advisors personally recruit foster youth to participate in the program, and college Program Directors coordinate the program at the college level. For more information, contact us at (323) 241-5291.

### Model Approach to Partnership in Parenting (P.S. MAPP)

This is a 36 hour Group Preparation and Selection (GSP) parenting class that will guide you as you consider how best to care for a foster child/children. P.S. MAPP is an educational experience that the Department of Children and Family Services (DCFS) requires you to complete before DCFS can place a Foster child/Adoptive child in your home.

### Summer Free Lunch Program

The Community Services Department sponsors a Free Lunch Program for children /youth 18 years and younger for the South Los Angeles Community. We are an open site, and lunch is served from noon to 1:00 pm, and snack is served from 4:00 pm to 5:00 pm Monday through Thursday during the summer months. This grant is from the Department of Education. For more information contact us at (323) 241-5241.

## BRIDGES TO SUCCESS

Student Services Building (SSB), Room 205  
 (323) 241-5281  
[www.lasc.edu/bts](http://www.lasc.edu/bts)



The Bridges to Success Center is available to assist non-native English speaking students and Citizenship applicants. The Center has two major functions: providing support to students to help them achieve their basic occupational and academic goals, and offering Citizenship application assistance, classes, and services.

The Center's staff conducts free Citizenship orientations, workshops, and review sessions open to all students and community members. In addition, the Bridges to Success Center offers basic English and Math classes to prepare students for placement into English 21 and Math 115. Assistance by the Center includes placement, orientation, registration, academic counseling, financial aid assistance, referral to campus support services, translation, and outreach.

### Faculty

Marian Ruane  
 Noncredit Program Coordinator

### Staff

Melvin Chilin ..... SFP Specialist  
 Roxana Guzman ..... SFP Technician  
 Mario Romero ..... SFP Technician

### Noncredit Program

Student Learning Outcomes:

Upon completion of the majority of these courses, students should be able to:

1. Listen to and speak with people of diverse backgrounds to fulfill communication tasks in their roles as workers, community members and/or lifelong learners.
2. Demonstrate effective computational, technological and critical thinking skills to process information in their roles as workers, community members and/or lifelong learners.
3. Demonstrate effective reading and writing skills to fulfill writing tasks in their roles as workers, community members and/or lifelong learners.

### Academic Preparation (ACAD PR) (Noncredit)

Student Learning Outcome: Upon the completion of this course, students should be able to:

1. Identify the main idea in authentic reading material.
2. Read, interpret, and respond to questions from a nonfiction reading passage.

### Basic Skills (BSICSKL) (Noncredit)

Student Learning Outcomes: Upon the completion of the majority of these courses, students should be able to:

1. Use basic English and critical thinking skills necessary to successfully transition to job training or begin working towards their certificate, degree or transfer goals.
2. Demonstrate basic Math skills necessary to successfully transition to job training or begin working towards their certificate, degree or transfer goals.

### English as a Second Language (Noncredit) (ESL NC)

Student Learning Outcomes: Upon the completion of the majority of these courses, students should be able to:

1. Understand oral communication in a variety of contexts.
2. Speak on a variety of topics in personal, social and work-related contexts.
3. Use increasingly complex grammatical patterns in oral and written forms.
4. Read and comprehend authentic texts on familiar topics.



5. Produce a variety of correspondence and short writings for application in personal, vocational and academic situations.

### ESL and Civics (Noncredit) (ESLCVCS)

#### Student Learning Outcomes:

Upon completion of the majority of these courses, students should be able to:

1. Accurately complete forms in English with personal information and be able to effectively communicate in oral and written form for life skills.
2. Express and respond to information in English in oral and written form for workplace and interpersonal communication.

### Vocational Education (VOCED)

Student Learning Outcome: Upon the completion of this course, students should be able to:

1. Send an email to the instructor with the correct email address, subject line and message body.
2. Follow directions to format a Word document as assigned by instructor

## CAREER & TECHNICAL EDUCATION

SoCTE 141 \* (323) 241-5247

<http://www.lasc.edu/socte>

Rick Hodge, Dean, Workforce Development

### WELCOME TO CAREER & TECHNICAL EDUCATION @ LASC

CTE engages students in learning and prepares them to meet critical workforce demands. We provide short-term CTE courses and programs in a variety of industry-focused areas that lead to certificates, credentials, and licenses necessary for the workplace. Most of the programs are designed to lead directly to employment, but many also prepare students for further education in the university system.

### SCHOOL OF CAREER & TECHNICAL EDUCATION (SOCTE) MISSION

The mission of LASC School of Career & Technical Education (SOCTE) is to serve the critical lifelong knowledge, training and skill development needs of individuals, organizations, and the community. We do this through certificate programs, continuing education, degree-related programs and community initiatives that support economic and workforce development.

Our goal is to be a major catalyst for continued economic, workplace, and career pathways in the South Los Angeles region. Whether you're starting a new career, building a company, or developing skills for the future, SOCTE has the resources you need to get started!

### THE CTE ADVISORY BOARD

The CTE advisory board is a representative group of individuals whose experience and abilities represent a cross section of the businesses and industries that pertain to the college's academic focus and emerging technologies. Federal and California regulations mandate that schools and institutions that operate career and technical education (CTE) programs establish and operate program advisory committees. These bodies serve a vital role in keeping CTE programs relevant, dynamic, and on the cutting edge.

The primary purposes of the CTE Advisory Board are to assist Los Angeles Southwest

College in:

1. Documenting industry focus that informs faculty and students of the relevant skills and competencies required within their industries for job placement and career success.
2. Informing and updating business and industry of the strategic plans, program needs, business and industry support desired for CTE programs/courses and students.

ADMINISTRATION

Erica Mayorga ..... SFP Director  
 Joseph Mendez ..... SFP Program Specialist  
 Workforce Development & Corporate Relations

Rodnette Berger ..... Senior Secretary  
 Linda Jones ..... SFP Technician  
 Karen Cifuentes ..... SFP Assistant,

Laura Manyweather ..... Acting Tech Prep Coordinator

CAREER TRANSFER / PATHWAYS & JOBS CENTER

**Director, Joyce Ashley**

Counselors:  
 Lisa Ford, Transfer

The Transfer Center offers a variety of services including transfer workshops, university application assistance , educational plans , and annual Transfer fairs.

At LASC, you can complete your freshman and sophomore equivalent coursework, then transfer to the college or university of your choice as a junior!

Outcomes:

After using the resources of the Career/ Transfer Center students will have awareness of Transfer services, they will be able to identify universities that offer their major, they will be able to successfully complete CSU/ IGETC requirements . Also students will be able to identify UC and private institutions.

Also, students will be able to demonstrate the use of the online university application systems, and will have awareness of transfer deadlines.

## ADMINISTRATIVE SERVICES

Cox Annex Building, Room 143

323-241-5467

[www.lasc.edu/administration/admin\\_services/index.html](http://www.lasc.edu/administration/admin_services/index.html)

Daniel Hall, Vice President, Administrative Services

Lynn Bebelle, Administrative Analyst, S.P.O.C.

Deborah Ward, Administrative Assistant

Lorraine Bell, Senior Personnel Assistant

Edward Francis, Payroll Assistant

The office of Administrative Services supervises

- Information Technologies
- Facilities, Maintenance & Operations
- Deputy Sheriff's Services



## INFORMATION TECHNOLOGIES

Vibha Gupta, Manager College Information Systems

James Ferrer .....	Computer Network Support Specialist
Aaron Guerrero .....	Sr. Computer and Network Support Specialist
Alex Taubr .....	Instructional Media Assistant
Vaznik Karabidian .....	Data Communications Specialist
Aubrey Xie .....	Assistant Computer Network Specialist

## FACILITIES, MAINTENANCE & OPERATIONS

Al Mah, Director of Facilities

### Facilities

Anthony Pierson, Custodial Supervisor

### Custodians

Brian Barnes	Malik Holmes
JamesBerry	Ronnie Ignant
Johnny Brown	Kim Livingston
Martha Daniel	Robert Mix
Kenneth Domio	Christzann Ozan
Derek Gipson	Voragit Prompongsatorn
Keon Hamilton	Ronald Roberts
Darrell Harris	Mark Williams
Howard Harvey	

### Maintenance & Operations

Blanchie Hollier, Plant Facilities Assistant  
Ismael V. Campuzano, Carpenter  
Nicolas Crown, HVAC Technician  
Gary Mayo, Plumber  
Brian Robinson, Stock Control Assistant  
Jose L. Tello, Painter  
Robert Zamora, General Foreman

### Maintenance Assistants

Jackson Chu	Grayr Karchikyan
Frank Havlac	Stanley Reed

### Electricians

Gerald Lee	Ricardo Silva
------------	---------------

### Gardeners

Philip Jones	Frank Le
Genaro Zamora	



## DEPUTY SHERIFF'S SERVICES

[www.lasc.edu/about\\_lasc/Campus\\_Crime\\_Stats.html](http://www.lasc.edu/about_lasc/Campus_Crime_Stats.html)

Sheriff Station

323-241-5311

Deputy Reginald Ducree, Deputy Sheriff  
Dreshawn Gilmore, Senior Office Assistant

The Los Angeles County Deputy Sheriff's Department serves LASC. The Sheriff's deputies are sworn law enforcement officers under California Penal Code Section 830.1 and, in compliance with state law, meet the Peace Officer Standards and Training requirements mandatory for all California law enforcement officers. In addition, college police officers undergo training specially designed to meet the needs and problems of a contemporary college.

Sheriff's deputies provide the campus population with patrol, traffic control, accident investigation, emergency first aid, and lost/found property service.

To contact the Sheriff's deputies and report a problem or make an inquiry, call any of the following numbers: (323) 241-5311 or (323) 241-5269. From the Emergency Blue Phone on campus, you may press the red button to reach the Sheriff's substation. No money is required and you will be immediately connected to the college police.

If there is an emergency and the Sheriff's deputies are unavailable, call 911 for outside emergency response.

Pamela Sanford, Associate Vice President, Administrative Services  
Student Services Building, Room 103

The office of the Associate Vice President of Administrative Services supervises

- College Store
- Business Office
- Mailroom
- Reprographics

### COLLEGE STORE

<http://www.lascbookstore.com/>

Student Services Building, Room 132

323-241-5091

Ronald Tatum, College Store Supervisor  
Bessie Rosario, Cashier

The College Store provides textbooks and instructional materials in a variety of formats including new, used, digital and rental. The College Store also carries a wide selection of general reading/study aids, greeting cards, gifts, and Los Angeles Southwest College imprinted clothing.

## BUSINESS OFFICE

<http://www.lasc.edu/students/businessoffice.html>

Student Services Building, Room 103

323-241-5301

Jason Zhu	Business Office Supervisor
Catherine Go	Accounting Technician
May Ma	Accounting Technician
Yolana Marroquin	Accounting Technician
Nune Mkhitarian	Accounting Assistant

The Business Office collects payments for fees, enrollment, tuition, parking, transcripts, and the ASO from students. The Business Office also provides assistance with student account balances, registration receipts, refund requests, and holds on student accounts. The Business Office is responsible for all campus fiscal reporting and services, including campus disbursements. The Business Office is committed to providing outstanding services to the students and campus community.

## MAILROOM &amp; REPROGRAPHICS

Cox Annex Building

Brian Bradshaw, Office Assistant  
James Flagg, Reprographics Equipment Operator



## ACADEMIC AFFAIRS

School of Career and Technical Education Building, Room 132  
323-241-5284

Dr. Lawrence Bradford, Vice President, Academic Affairs

Darlene Comegys, Administrative Secretary  
Cassandra Walker, Academic Scheduling Specialist  
Maria Cortez, Administrative Aide

The Office of Academic Affairs is the division of Los Angeles Southwest College that deals with the Academic, Educational and Community Services. Academic Affairs is responsible for the following:

- Academic operation and planning
- Faculty Hiring, Evaluation and Support
- Curriculum planning and organization
- Course evaluation and offerings
- eLearning and Distance Learning
- Special Programs



## LASC DEANS

### Academic Affairs

- Tangelia M. Alfred (2005),  
Curriculum, Natural Sciences, Health, Kinesiology, and Mathematics  
*B.A., California State University Bakersfield*  
*M.A., San Diego State University*  
*Ed.D., California State University Long Beach*
- Rick Hodge (2014),  
Career & Technical Education (Workforce)  
*B.S., University of Oregon*  
*B.A., Walla Walla College*  
*M.Div., Andrews University*
- Allison P Moore (2001),  
Arts & Humanities, Behavioral & Social Science, Distance Education, English & Foreign  
Language, and Library  
*B.S., University of Southern California*  
*M.Acc., University of Southern California*  
*D.P.A., University of LaVerne*

### Student Services

- Reginald Morris (2016)  
Student Services  
*A.A., Los Angeles, Harbor College*  
*B.S., San Jose State University*  
*M.A., California Lutheran College*

### President's Office

- Jose A. Gallegos (2016)  
Institutional Advancement  
*B.A., California State University Los Angeles*  
*M.A., California State University Los Angeles*



## ELEARNING AND DISTANCE LEARNING

The technology for eLearning has undergone rapid changes in the last decade. LASC has embraced the changing nature of eLearning technologies and is creating some of the most innovative and responsive educational programs and delivering them with an eye toward convenience and accessibility. LASC's eLearning mission is to extend knowledge beyond the boundaries of the campus - out to where students live, work and study. Through Distance Learning (DL) and Instructional Television (ITV), we deliver a wide range of programs that make a difference to students, literally anywhere. We have adopted some of the latest Web 2.0 collaborative online tools and technologies, like wikis, blogs, online communities, secure social networks and other technologies that make the resources of LASC accessible to everyone who has a computer and a desire to keep learning.

In keeping pace with the changing technologies of eLearning, the focus of the DL program has switched from managing courses in course management systems (CMS) to managing learning through Learning Management Systems (LMS). This enables LASC to expand its eLearning program mission to include enhancing student success through learning relationships. Instructors create collaborative learning community environments that engage students from the moment they apply until graduation and beyond. Students remember the teachers who inspired them, the study groups that challenged them, and the people who impacted their lives. The learning communities encourage synthesis, discussions and debate, while removing elements of disconnect between students, their peers and instructors, and foster a sense of face-to-face time and a feeling of "connectedness."

Distance Learning comprises the fastest growing educational delivery mode in California community colleges. The mission of the Distance Learning program at LASC is to promote student access and student success by integrating some of the programs and services using technology-mediated instruction and to develop and promote effective distance learning paradigms.

Distance Learning provides you with the convenience of attending classes in a "virtual world" without the limitations of time and travel. Please visit the college website at [www.lasc.edu](http://www.lasc.edu), click on the for Students link and then click the Online Classes link. There, you will find a wealth of information on the Distance Learning program here at Los Angeles Southwest College and it will help you decide if Distance Learning and online classes are right for you. When you are ready to enroll in an online class, just visit the Online Classes website at <http://online.lasc.edu>.

The Distance Learning program is assisted by the Educational Technology Advisory Council (ETAC) which, through its publications, advises the Chancellor's Office on the vision, policy, and planning in support of Distance Education and Educational Technology.

**Online Courses and Programs** The College offers online classes in the following disciplines:

Anthropology  
Art  
Biology  
Business  
Child Development  
Computer Applications Office Technologies  
Computer Science – Information Technology Counseling  
English  
Health  
History  
Humanities  
Library Science  
Microbiology  
Music  
Political Science  
Psychology  
Sociology

#### ATHLETICS

[www.lasc.edu/athletics/index.html](http://www.lasc.edu/athletics/index.html)

323-241-5256 (Athletic Secretary)

323-241-5432 (Athletic Director)

The Department of Intercollegiate Athletics is the unit responsible for the supervision of intercollegiate athletic programs. The department sponsors a diverse program of intercollegiate athletics for men and women at the community college level, competing under the rules of the Commission on Athletics, the South Coast Conference, and the Southern California Football Association.

LASC's athletics' program offers three sports programs. The women's varsity sport is basketball, and the men's varsity sports are basketball and football.

Any student wishing to enroll in an intercollegiate athletic program must meet all eligibility requirements, as well as LASC admission requirements and deadlines.

Henry Washington, Football Coach  
Calvin Kyles, Sr., Men's Basketball Coach  
La'Nette Dilliard, Women's Basketball Coach  
Wilbert Knight, Assistant Coach  
Wilda A Bingham, Athletic Trainer

#### FACULTY HIRING, EVALUATION AND SUPPORT

##### **Equal Employment Opportunity (EEO)**

The goal of Los Angeles Community College District is to ensure equal opportunity to all qualified employees and applicants for employment without regard to race, color, national origin, ancestry, religion, creed, sex, age, disability, marital status, or sexual orientation. Positive action will be taken to ensure that this non-discrimination policy is followed in all personnel practices, including recruitment, hiring, placement, upgrading, transfer, demotion, and pay practices.



## To Initiate a Complaint About the LACCD Equal Opportunity Policy

### Summary of Equal Opportunity Policy

Los Angeles Southwest College and the Los Angeles Community College District (LACCD) are committed to the philosophy of equal opportunity/equal access in all its employment, educational programs, and services. Thus, we are firmly committed to a policy of nondiscrimination on the basis of actual or perceived ethnic group identification, race, color, national origin, ancestry, religion, creed, sex (including gender-based sexual harassment), pregnancy, cancer-related medical condition of an employee, marital status, sexual orientation, age, physical or mental disability, or veteran status in our employment and educational programs and activities.

### Equal Opportunity Policy Compliance Procedure

In order to ensure compliance with the Equal Opportunity Policy at Los Angeles Southwest College, please direct inquiries to Dr. Lawrence Bradford, Vice President, Academic Affairs, 323-241-5280. In addition, inquiries may be directed to the District Office of Diversity Programs at (213) 891-2315.

### Discrimination

<http://www.laccd.edu/Departments/DistrictResources/OfficeOfDiversity/Pages/Discrimination.aspx>

The LACCD in accordance with applicable Federal and State laws and District policy, prohibits discrimination against any student, faculty, staff, person acting on behalf of LACCD, applicant and general public associated with LACCD based on race, color, national origin, ethnic group identification, ancestry, religion, creed, sex or gender (including sexual harassment), pregnancy, marital status, medical condition (cancer-related), sexual orientation, age, physical or mental disability, and perceived to be in a protected category or associated with those in protected category and veteran status.

### Sexual Harassment

<http://www.laccd.edu/Departments/DistrictResources/OfficeOfDiversity/Documents/Summary-2013.pdf>

It is the policy of the Los Angeles Community College District to provide an educational, employment and business environment free from Prohibited Discrimination. Employees, students or other persons acting on behalf of the District who engage in Prohibited Discrimination as defined in this policy or by state or federal law shall be subject to discipline, up to and including discharge, expulsion or termination of contract.

## To Initiate a Complaint About Sexual Harassment

### Sexual Harassment Complaint Procedure

In order to ensure compliance with the Sexual Harassment Policy at Los Angeles Southwest College, please direct inquiries to Dr. Lawrence Bradford, Vice President, Academic Affairs, 323-241-5280. In addition, inquiries may be directed to the District Office of Diversity Programs at (213) 891-2315.

The specific rules and procedures for reporting charges of sexual harassment and for pursuing available remedies are incorporated in the Board Rules in Chapter 15. The Los

Angeles Community College District has a policy that provides formal and informal procedures for resolving complaints. Copies of the policy and procedures may be obtained by calling the District Office of Diversity Programs at (213) 891-2315.

All members of the college community, which includes student, faculty, and staff, who believe they have experienced conduct that may constitute sexual harassment, have the right to seek help from the college. Every employee has the responsibility to report such conduct to the LASC Compliance Officer when it is directed toward students. Potential complainants are advised that administrative and civil law remedies, including but not limited to injunctions, restraining orders, or other orders, may be made available.

THE PROTOCOL TO ADDRESS STUDENT COMPLAINTS THAT ARE INSTRUCTOR RELATED IS DESCRIBED IN THE STEPS BELOW:

- **Instructor of Record** – The student must first seek to resolve the concern with the instructor of record.
- **Department Chair** – If the student does not agree with the outcome of their meeting with the instructor or would like to take their concern to the next level, they should be recommended to the department chair.
- **Academic Dean** – If the student does not agree with the decision of the department chair or would like to take their concern to the next level, they should be recommended to go to the appropriate academic dean.
- **Ombudsperson** (for grievance in accordance with E-55) – If the matter cannot be remedied by an academic dean to the satisfaction of the student, and the student would like to seek further recourse, the student should be recommended to the ombudsperson (who is housed in the Student Services Division), as the student has the right to grieve their concern. The grievance process is a formal process, which the grievant presents their argument in a written format to a pre-selected grievance committee of faculty, administrators, and students.
- **Grievance Appeal Committee** – In accordance with E-55, if a student does not agree with the decision of the grievance committee, the student may appeal the decision. This committee is comprised of the VP of Academic Affairs, VP of Student Services, Academic Senate President, and a faculty member, appointed by the Senate. The written recommendation of the grievance appeals committee, after the concerns has been heard, is sent to the President, for the final decision at the campus level.



## GRADUATION REQUIREMENTS

### Graduation Requirements

Associate in Arts or Associate in Science Degree: The Board of Governors of the California Community Colleges has authorized the Los Angeles Community College District Board of Trustees to confer the degrees of Associate in Arts and Associate in Science. (6200.00)

#### MAJOR REQUIREMENTS:

- At least 18-36 semester units of study taken in single or related disciplines.
- All courses that meet the major requirements of the educational programs listed in the catalog may be applied toward graduation requirements for the Associate Degree. All transfer courses may be applied to the Associate Degree. Some courses, which are offered for college credit, but which cannot be applied toward graduation requirements for the Associate Degree, are designated as NDA, non-degree applicable.
- See the following pages for specific information about the LACCD General Education Plan.

**UNIT REQUIREMENT:** A minimum of 60 semester units of course credit in a selected curriculum with at least 18 semester units of study in a major or area of emphasis and at least 18 semester units of study in general education. (6201.10)

**SCHOLARSHIP REQUIREMENT:** A “C” (2.0) grade point average or better in all work attempted in the curriculum upon which the degree is based. (6201.11)

**COMPETENCY REQUIREMENTS:** Competence in written expression shall be demonstrated by obtaining a satisfactory grade in English 101, or another English course at the same level and with the same rigor as recommended by the District Academic Senate and approved by the Chancellor. Competence in mathematics shall be demonstrated by obtaining a satisfactory grade in Mathematics 125 (Intermediate Algebra), or another mathematics course at the same level and rigor, or higher, and with elementary algebra or higher as a prerequisite, as recommended by the District Academic Senate and approved by the Chancellor. (6201.12)

**ACADEMIC RESIDENCE REQUIREMENTS:** Completion of at least 12 units of work in residence with at least six (6) units in the major for the degree being awarded, at the college conferring the degree. The governing Board may make exceptions when it determines that an injustice or undue hardship would be placed on the student. (6201.13)

**CATALOG RIGHTS:** A student remaining in continuous attendance in the Los Angeles Community College District may elect to satisfy the degree, certificate or graduation requirements in effect at the college from which the student will either earn his/her degree, certificate or graduate at the time the student began such attendance at the college. (6202.00)

**PETITIONING FOR GRADUATION:** All students meeting degree or certificate requirements must complete the petition in order to qualify to receive the degree or certificate. Students should contact a Counselor while in their last semester of classes in order to file the petition. All course work must be completed or in progress at the time of filing. The graduation petition document is used to process a student’s record of course work to qualify for and to receive the Associate Degree and participate in the Commencement Ceremony.

The first day to file a Graduation Petition follows the last day to add a class a date that is

noted in both the Fall and Spring Schedules of Classes. Note the last day to file a petition, as specified in the schedules also. Petitions may also be filed during the summer sessions; note the filing period in the Summer Schedule of classes. Course work taken at institutions outside the Los Angeles Community College District must be documented with an official transcript filed in the Office of Admissions and Records.

### University Transfer Information

Throughout the state of California, the community college system generally provides the equivalent of the first two years of a four-year university education. By choosing courses approved by the university systems, you may transfer your credit earned at the community college level and enter the university in your third (Junior) year of education. There are two public California university systems: the California State University system (CSU) and the University of California system (UC).

**ASSOCIATE DEGREES FOR TRANSFER:** California Community Colleges are now offering associate degrees for transfer to the CSU system. These may include Associate in Arts (AA-T) or Associate in Science (AS-T) degrees. These degrees are designed to provide a clear pathway to a CSU major and baccalaureate degree. California Community College students who are awarded an AA-T or AS-T degree are guaranteed admission with junior standing somewhere in the CSU system and given priority admission consideration to their local CSU campus or to a program that is deemed similar to their community college major. This priority does not guarantee admission to specific majors or campuses.

LASC currently offers the following Associate Degrees for Transfer:

- ◆AS-T Administration of Justice
- ◆AA-T Anthropology
- ◆AS-T Business Administration
- ◆AA-T Communication Studies
- ◆AS-T Early Childhood Education
- ◆AA-T English
- ◆AA-T History
- ◆AA-T Journalism
- ◆AS-T Mathematics
- ◆AS-T Physics
- ◆AA-T Political Science
- ◆AA-T Psychology
- ◆AA-T Sociology
- ◆AA-T Spanish
- ◆AA-T Studio Arts
- ◆AA-T Theatre Arts

Students who have been awarded an AA-T or AS-T are able to complete their remaining requirements for the 120-unit baccalaureate degree within 60 semester or 90 quarter units. Current and prospective community college students are encouraged to meet with a counselor to review their options for transfer and to develop an educational plan that best meets their goals and needs.

### WHAT YOU NEED TO TRANSFER:

You need a total of **60 Transferable Units** earned in **General Education** and in your **Major**.





## Transferable Units

Transferability is listed for each course in “Course Descriptions”. You will find the transfer designation after the number of units for the course. If “CSU” is noted, it means the course is accepted for credit by any CSU in California. If “UC” is noted, it means the course is accepted for credit by any UC in California. When both are noted (“UC:CSU”), it means the course credit is approved for transfer by both the CSU and UC systems.

### General Education, CSU

General Education requirements to transfer to a California State University are satisfied by completing the list of courses known as the “CSU-GE” curriculum. Completion of 15 selected courses from Areas A-F satisfies the General Education requirement for transfer to any CSU. Note that 2 courses in Area F may be double-counted, making the total 13 courses. Your grade point average must be at least a “C” or 2.0. You must complete Areas A (Communication in the English Language and Critical Thinking) and B4 (Mathematics/Quantitative Reasoning) with a “C” or better.

### General Education, UC

General Education requirements to transfer to a University of California are satisfied by completing courses from the list known as “IGETC”. Completion of 14 selected courses from Areas 1-5 and Area 7 satisfies the General Education requirements for transfer to a UC. Note that Area 6 (Languages Other Than English) may be satisfied in various ways, including taking a class in a foreign language. You must complete all Areas with a “C” grade or better.

### Transferring to a Private University or Out-of-State College

Private schools and those outside the state of California have their own specific transfer requirements. (Their requirements are not listed on <http://www.assist.org>, which is for California public institutions only.) Some of the schools maintain their own websites that list the courses required for General Education, your major, and transfer for each school in California. Those lists of requirements are known as Articulation Agreements.

For example, you may find the Articulation Agreement between LASC and the University of Southern California (a private institution) on the USC website at [www.usc.edu/articulation](http://www.usc.edu/articulation).

### Credits Earned at Other Schools

If you attended another college or university in the United States, LASC will accept all of your units if the school is regionally accredited. If you studied at a California public institution, each course will be accepted for LASC General Education credit in the area in which it is accepted at the school where you took the course. This is also true for areas approved for that school for CSU-GE and IGETC curricula. This procedure of accepting credit in the state of California is known as “pass-along credit.” Courses taken at a private school or outside of the state of California will be accepted for General Education if the course is equivalent to a course that is required by LASC. Determinations are generally made on the basis of the Course Description and hours studied.

Courses will be accepted for the Major if they are equivalent to courses required by LASC. Determinations are generally made on the basis of the Course Description and hours studied.

For further information, see a General Counselor in Student Services Building, Room 227.



## Associate Degree – General Education Requirements

General Education Requirements: Minimum of 21 semester units

Major Requirements: Minimum of 18 units in a single or related field

Each course counted towards the major or area of emphasis must be completed with a "C" (2.0 or equivalent) or better, or a "P" if the course is taken on a "pass-no pass" basis. See a counselor and check the college catalog for specific major requirements.

<b>AREA A—NATURAL SCIENCES</b>	<b>3 Semester Units Minimum</b>
<p>Anatomy <u>1</u>; Anthropology 101, 103; Astronomy 1; Biology <u>3</u>, <u>5</u>, <u>6</u>, <u>7</u>, <u>20</u>; Chemistry <u>51</u>, <u>101</u>, <u>102</u>, <u>211</u>, <u>212</u>;                  Environmental Science 1, 2; Geography 1, 7, 14; Geology 1, 2; Microbiology <u>1</u>; Physical Science 1;                  Physics <u>6</u>, <u>7</u>, <u>37</u>, <u>38</u>, <u>39</u>; Physiology <u>1</u>; Psychology 2</p>	
<b>AREA B—SOCIAL AND BEHAVIORAL SCIENCES AND AMERICAN INSTITUTIONS</b>	<b>6 Semester Units Minimum</b>
<p>B1. American Institutions (3 Semester Units Minimum)                  History 5, 11, 12, 41, 42, 43; <b>Political Science 1</b></p> <p>B2. Social and Behavioral Sciences (3 Semester Units Minimum)  <b>Accounting 1</b>; <b>Administration of Justice 1</b>, 63, 180; <b>African American Studies 2</b>, 7;  <b>Anthropology 102</b>, 103, 121, 132; 133; <b>Business 1</b>, 5, 6; <b>Chicano 2</b>, 4; <b>Child Development 1</b>; <b>Communication Studies 122</b>, 190;  <b>Economics 1</b>, 2; <b>Education 203</b>, 204; <b>Environmental Studies 101</b>; <b>Geography 2</b>, 7, 14; <b>Health 21</b>; <b>History 1</b>, 2, 3, 5, 12, 37, 52;  <b>International Business 602</b>, 603; <b>Law 3</b>, 13; <b>Political Science 2</b>, 5, 7, 9, 19, 20, 50; <b>Psychology 1</b>, 11, 14, 41;  <b>Sociology 1</b>, 2, 4, 7, 11, 12, 19, 23, 45; <b>Supervision 1</b>, 6, 12</p>	
<b>AREA C—HUMANITIES</b>	<b>3 Semester Units Minimum</b>
<p><b>American Sign Language 1</b>, 2, 3; <b>Anthropology 104</b>; <b>Art 101</b>, 102, 103, 104, 201, 213, 300, 307, 501, 502; <b>Art History 126</b>, 130, 140;  <b>Communication Studies 130</b>; <b>English 111</b>, 127, 211, 212, 213, 215, 223, 234, 240; <b>French 1</b>; <b>Humanities 1</b>, 2, 6, 31;  <b>Music 101</b>, 111, 116, 141, 650; <b>Philosophy 1</b>; <b>Spanish 1</b>, 2, 3, 4, 8, 14, 24; <b>Theater 100</b>, 110, 114, 130, 231, 240, 270, 271, 291, 300</p>	
<b>AREA D—LANGUAGE AND RATIONALITY</b>	<b>6 Semester Units Minimum</b>
<p>D1. English Composition (3 Semester Units Minimum)  <b>English 28</b>, 101*, <b>Journalism 101</b></p> <p>D2. Communication and Analytical Thinking (3 Semester Units Minimum)  <b>Communication Studies 101</b>, 104, 121, 122, 151, 190; <b>Computer Science 601</b>, 607, <b>English 102</b>, 103; <b>Library Science 101</b>; <b>Math 115</b>, 122, 125*, 216, 227, 230, 235, 236, 240, 245, 260, 265, 266, 267, 270, 275; <b>Philosophy 8</b>; <b>Psychology 91</b>, 92; <b>Supervision 4</b></p> <p style="text-align: center;"><i>*English 101 and Math 125 required as of Fall 09; see Competency Requirements</i></p>	
<b>AREA E—HEALTH AND PHYSICAL EDUCATION*</b>	<b>3 Semester Units Minimum</b>
<p>E1. Health Education Note: Health 2 includes the physical education activity (2 Semester Units Minimum)  <b>Family and Consumer Science 21</b>; <b>Health 2</b>, 8, 11, 12</p> <p>E2. PHYSICAL EDUCATION ACTIVITY (1 Semester Units Minimum)  <b>Dance Studies 814</b>; <b>Dance Techniques 121</b>; <b>Kinesiology 180-391</b>; <b>Kinesiology Athletics 504</b>, 508, 552; <b>Kinesiology Major 101</b>, 111</p> <p style="text-align: center;"><i>*Military Credit awarded for Area E with acceptable documentation; Nursing students are exempt from Health</i></p>	



## The Los Angeles Southwest College Associate Degree Common Requirements: Title 5: 55063

### 1. Unit Requirement: (LACCD BOARD RULES - CH. VI, ARTICLE II)

A minimum of 60 semester units in degree applicable courses.

### 2. General Education Requirement: (LACCD BOARD RULES - CH. VI, ARTICLE II)

For every major, you must complete a series of courses that make up the general education requirement of the degree. While a course might satisfy more than one general education requirement, it may not be counted more than once for these purposes. A course may be used to satisfy both a general education requirement and a major requirement.

### 3. Major Requirement: (LACCD BOARD RULES - CH. VI, ARTICLE II)

In addition to the general education requirements, each degree requires a major. Effective for students admitted to a community college for the fall 2009 term, or any term thereafter, each course counted toward the major requirement must be completed with a grade of "C" or better or a "P" if the course is taken on a "pass-no pass" basis. A course may be used to satisfy both a general education requirement and a major requirement.

### 4. Scholarship Requirement: (LACCD BOARD RULES - CH. VI, ARTICLE II)

A minimum "C" (2.0) cumulative grade point average in all courses used toward the degree. Effective for all students admitted for the Fall 2009 term or any term thereafter, each course counted toward the major requirements must be completed with a grade of "C" or better or a "P" if the course is taken on a "pass-no pass" basis.

### 5. Degree Requirement: (LACCD BOARD RULES - CH. VI, ARTICLE II)

Students must complete no fewer than 12 units at the college conferring the degree. When the same major is offered at multiple colleges in the LACCD, the degree shall be conferred by the college where the student has taken the majority (greater than 50.0%) of units in the major.

### 6. Competency Requirement: (LACCD ADMINISTRATIVE REGULATIONS - E-79)

Mathematics Competency: The competency requirement in mathematics for the Associate Degree may be met by completion of one of the following:

- a. Completion of Mathematics 125: Intermediate Algebra (or the equivalent from another college) with a grade of "C" or better or any higher-level mathematics course with a prerequisite of at least Mathematics 125 or the equivalent  
OR
- b. A passing score on the Los Angeles Community College District Intermediate Algebra Competency Examination  
OR
- c. A score of 3 or higher on one of the following Advanced Placement (AP) exams: Calculus AB, Calculus BC, Statistics  
OR
- d. Complete the Los Angeles Southwest College assessment exam in mathematics and achieve a score determined comparable to satisfactory completion of Math 125, Intermediate Algebra. That is, students who place into a mathematics course above the level of intermediate algebra have met the competency requirement.

Reading & Written Expression Competency: The competency requirement in reading and written expression for the Associate Degree may be met by completion of one of the following:

- a. Completion of English 101 (or the equivalent from another college) with a grade of "C" or better  
OR
- b. A score of 3 or higher on one of the following Advanced Placement (AP) Exams: English Language and Composition, English Composition and Literature  
OR
- c. Completion of English 101 through credit-by-examination. Students must meet the eligibility requirements for credit-by-examination. Refer to Credit-by-Examination section of the catalog for details.  
OR
- d. Completion of the college assessment exam in English and achievement of a score determined comparable to satisfactory completion of English 101. That is, students who place into an English course above the level of English 101 have met the competency requirement. (Board Rule 6201.12, Title 5, CCR, 55063)

### Transfer Students

Completing the Associate Degree does not necessarily meet the university-admission requirements for transfer. An Associate Degree is not a requirement for transfer to either the CSU or UC campuses. Private and out-of-state colleges and universities have unique transfer requirements. However, if you would like to transfer to a university and earn an associate degree, early educational planning can make this goal achievable. You should meet with a counselor early in your studies to develop an Educational Plan that fulfills both transfer requirements and associate degree requirements.

### Procedure for requesting the degree:

You must file a Graduation Petition for the degree in the Counseling Office. Please check the Schedule of Classes for deadlines. If you have completed coursework at other schools that you believe meets some of your degree requirements, you may petition for course substitution with a Los Angeles Southwest College counselor.

(updated as of 05/26/2016)

# CALIFORNIA STATE UNIVERSITY GENERAL EDUCATION/CSU-GE CERTIFICATION

**AREA A- ENGLISH LANGUAGE COMMUNICATION AND CRITICAL THINKING**

9 semester units required with at least one course each from A1, A2 and A3

**A1 - Oral Communication**

Communication Studies 101

**A2 - Written Communication**

English 101

**A3 - Critical Thinking**

English 102, English 103; Philosophy 8

**AREA B-SCIENTIFIC INQUIRY AND QUANTITATIVE REASONING**

9 semester units required with at least one course each from Physical Science, Life Science (at least one to contain a laboratory component) and Mathematics/Quantitative Reasoning

**B1 - Physical Science**

Astronomy 1; Chemistry 51, 101, 102, 211, 212; Environmental Science 1; Geography 1; Geology 1; Physical Science 1; Physics 6, 7, 37, 38, 39

**B2 - Life Science**

Anatomy 1; Anthropology 101; Astronomy 5; Biology 3, 5, 6, 7, 20; Environmental Science 2; Microbiology 1; Physiology 1; Psychology 2

**B3 - Laboratory Activity**

Anthropology 111; Geology 6; Physical Science 14

This requirement may also be met by completion of any lecture with lab course listed in Area B1 or B2 above that is underlined.

**B4 - Mathematics/Quantitative Reasoning (completed with a "C" or better for CSU admission)**

Math 215, 227, 230, 235, 236, 240, 245, 260, 265, 266, 267, 270, 275

**AREA C-ARTS AND HUMANITIES**

9 semester units required with at least one course each in Arts and Humanities

**C1 - Arts (Arts, Cinema, Dance, Music, Theater)**

Art 101, 102, 103, 104, 201, 300, 501; Art History 126, 130, 140; Music 111,116, 141; Theater 100, 110

**C2 - Humanities (Literature, Philosophy, Languages Other than English)**

American Sign Language 1, 2; Anthropology 104; English 102, 207, 208, 211, 212, 213, 215, 234; French 1, 2; History 1,2; Humanities 1, 2, 6, 31; Philosophy 1; Spanish 1, 2, 3, 4; Communication Studies 130

**AREA D-SOCIAL SCIENCES**

9 semester units required with courses in at least 2 disciplines

**D0 - Sociology and Criminology**-Administration of Justice 63; Health 21; Sociology 1, 2, 11, 45

**D1 - Anthropology and Archeology**-Anthropology 102, 103, 104, 133

**D2 - Economics**-Economics 1, 2,

**D3 - Ethnic Studies**- African American Studies 2, 7; Chicano Studies 2, 4; History 41, 42, 43; Political Science 20; Sociology 11

**D4 - Gender Studies**-History 52; Political Science 19

**D5 - Geography**-Geography 2, 14

**D6 - History**-History 1, 2, 5, 11, 12, 41, 42, 43, 52; Humanities 6

**D7 - Interdisciplinary Social or Behavioral Science**- Chicano Studies 2, 4; Child Development 1; Education 204; Environmental Studies 101; Health 21; Sociology 45

**D8 - Political Science, Government and Legal Institutions**-Administration of Justice 1, 2; African American Studies 2, 7; History 11, 12; Law 3; Political Science 1, 2, 5, 7,19, 20, 50

**D9 - Psychology**-Psychology 1, 11, 14, 41

**AREA E-LIFELONG UNDERSTANDING AND SELF-DEVELOPMENT**

3 semester units, not all in physical activity

Family and Consumer Studies 21; Health 2, 8, 11, 21; Counseling 20; Environmental Science 2; Kinesiology 201\*,217\*, 251\*, 303\*\*, 334\*, 345\*, 552\*\*, 701\*\*; Psychology 3, 41; Sociology 12

**NOTE:** \* = 1 unit; \*\* = 2 units

**CSU U.S. HISTORY, CONSTITUTION AND AMERICAN IDEALS Graduation Requirement**

2 courses (6 semester units)

**Choose one course from Group 1 and one course from Group 2.**

**Group 1:** Historical Development of American Institutions and Ideals

History 5, 11, 12, 41, 42, 43

**Group 2:** US Constitution and Government/ California State and Local Government

Political Science 1



**What is the CSU General Education Certification plan?** The CSU GE plan is a program of coursework that allows students to fulfill 39 units of general education requirements prior to transfer.

**What are the CSU transfer admission requirements?** Students may qualify to transfer to California State Universities when they have completed a minimum of 60 transferable units with a grade point average of 2.0 or better. While courses with a grade of “D” are acceptable to fulfill areas, a minimum grade of “C” is required in Areas A1, A2, A3 and B4 in order to qualify for admission.

**What is the value of transferring with certification?** Completion of the California State University General Education (CSU-GE) requirements will allow a student to transfer from a California community college to a Cal State University without the need, after transfer, to take additional lower division general education courses.

**Must the entire CSU GE certification plan be completed prior to transfer?** No. Students who do not fulfill requirements for all of the areas may request “partial certification” of the GE plan. Only the completed areas will be certified. After transfer, students will be subject to the general education requirements in non-certified areas of the CSU campus they attend.

**When do students apply for certification?** Students should apply for CSU certification at the end of their last semester.

**Where do students apply for certification?** Students complete the CSU GE certification forms with a Counselor; the student is responsible for turning the certification form in to the Office of Admissions and Records.

**Do courses taken at another college count towards certification?** If courses from another college are being used towards certification, Los Angeles Southwest College will place the courses in the CSU areas identified by the offering college. Courses taken at 4-year institutions must be equivalent to courses offered at Los Angeles Southwest College. Courses from accredited out-of-state institutions may also be used. Courses taken at a foreign institution may not be certified.

**What do students do to notify the CSU or UC of the certification?** Students must complete the Transcript Request form in the Office of Admissions and Records, requesting the final transcript to be sent to their chosen CSU or UC. They must check the box “State College Certification/IGETC” on the transcript request form. The record of the areas of certification will then be listed on the transcript that is sent to the university.

**Web Address for all Cal State Universities:** [www.csumentor.edu](http://www.csumentor.edu)

### Individual CSU Web Addresses:

CSU Bakersfield: <a href="http://www.csub.edu">www.csub.edu</a>	CSU Northridge: <a href="http://www.csun.edu">www.csun.edu</a>
CSU Channel Islands: <a href="http://www.csuci.edu">www.csuci.edu</a>	Cal Poly Pomona: <a href="http://www.csupomona.edu">www.csupomona.edu</a>
Chico State: <a href="http://www.csuchico.edu">www.csuchico.edu</a>	Sacramento State: <a href="http://www.csus.edu">www.csus.edu</a>
CSU Dominguez Hills: <a href="http://www.csudh.edu">www.csudh.edu</a>	CSU San Bernardino: <a href="http://www.csusb.edu">www.csusb.edu</a>
CSUEastBay: <a href="http://www20.csueastbay.edu">www20.csueastbay.edu</a>	San Diego State: <a href="http://www.sdsu.edu">www.sdsu.edu</a>
CSU Fresno: <a href="http://www.csufresno.edu">www.csufresno.edu</a>	San Francisco State: <a href="http://www.sfsu.edu">www.sfsu.edu</a>
CSU Fullerton: <a href="http://www.fullerton.edu">www.fullerton.edu</a>	San Jose State: <a href="http://www.sjsu.edu">www.sjsu.edu</a>
CSU Humboldt: <a href="http://www.humboldt.edu">www.humboldt.edu</a>	Cal Poly SLO: <a href="http://www.calpoly.edu">www.calpoly.edu</a>
CSU Long Beach: <a href="http://www.csulb.edu">www.csulb.edu</a>	CSU San Marcos: <a href="http://www.csusm.edu">www.csusm.edu</a>
CSU Los Angeles: <a href="http://www.calstatela.edu">www.calstatela.edu</a>	Sonoma State: <a href="http://www.sonoma.edu">www.sonoma.edu</a>
California Maritime Academy: <a href="http://www.csum.edu">www.csum.edu</a>	CSU Stanislaus: <a href="http://www.csustan.edu">www.csustan.edu</a>
CSU Monterey Bay: <a href="http://www.csumb.edu">www.csumb.edu</a>	

**For further information, please see a counselor.** (updated as of 5/24/2016)

**INTERSEGMENTAL GENERAL EDUCATION TRANSFER CURRICULUM  
2016-2017 IGETC Certification**

**AREA 1-ENGLISH COMMUNICATION**

UC - 2 courses required, one each from group A and B.  
CSU - 3 courses required, one each from group A, B and C.

**1A - English Composition (1 course, 3 semester units)**

English 101

**1B - Critical Thinking-English Composition (1 course, 3 semester units)**

English 102 or English 103

**1C – Oral Communication - CSU requirement only (1 course, 3 semester units)**

Communication Studies 101

**AREA 2-MATHEMATICAL CONCEPTS & QUANTITATIVE REASONING (1 course, 3 semester units)**

2A - Mathematics 227, 230, 2350, 2360, 2450, 2600, 2650, 2660, 267, 270, 275

**AREA 3-ARTS AND HUMANITIES (9 semester units minimum)**

At least 3 courses, with at least one course from the Arts and one course from Humanities.

**3A - Arts:** Art 101, 102, 103, 104; Music 111, 116; Theater 100, Theater 110

**3B - Humanities:** American Sign Language 3; Anthropology 104; English 211, 212, 213, 215, 234; French 2\*; History 1,2,5,11,12; Humanities 1, 31; Philosophy 1; Spanish 2\*, 3\*, 4\*

**AREA 4- SOCIAL AND BEHAVIORAL SCIENCES**

At least 3 courses from at least 2 disciplines (9 semester units)

Administration of Justice 63; Anthropology 102, 103,104,133; Economics 1, 2; Environmental Studies 101; Geography 2; History 1\*,2\*,5\*,11\*,12\*, 41\*, 42\*, 43\*, 52; Political Science 1, 2, 7, 19, 20; Psychology 1, 410; Sociology 1, 2, 4,11

**AREA 5- PHYSICAL AND BIOLOGICAL SCIENCES**

At least 2 courses, one Physical Science course and one Biological Science course (7-9 semester units);  
at least one must include a laboratory, courses that include a laboratory class are underlined

**5A. Physical Science:** Chemistry 510, 101, 102, 211, 212; Environmental Science 1; Geography 1; Geology 1; Physical Science 10;  
Physics 60, 70, 370, 380, 390

**5B. Biological Science:** Anatomy 10; Anthropology 101; Biology 30, 50, 6, 7, 200; Environmental Science 2; Microbiology 1;  
Physiology 10; Psychology 2

**5C. Science Laboratory:** Geology 6, Physical Science 14

This requirement may also be satisfied by completion of any lecture with lab course listed in Area 5A or 5B above that is underlined.

**AREA 6- LANGUAGES OTHER THAN ENGLISH (UC Requirement ONLY)**

Proficiency equivalent to two years of high school study in the same language

American Sign Language 1, 2, 3; French 1, 2\*; Spanish 1, 2\*, 3\*, 4\*

**CSU GRADUATION REQUIREMENT IN U.S. HISTORY, CONSTITUTION AND AMERICAN IDEALS**

These courses are not part of IGETC and may be completed prior to transfer.

**2 courses (6 units); one course from Group 1 and one course from Group 2.**

**Group 1: Historical Development of American Institutions and Ideals:**

History 5, 110\*, 120\*, 410\*, 420\*, 430\*

**Group 2: US Constitution & Government/California State & Local Government:**

Political Science 1\*

**NOTES:**

*The IGETC curriculum is recommended for transfer to a UC or CSU. All Areas must be completed with "C" or better.*

◊ Transfer credit is limited by either UC or CSU or both. Please consult with a counselor.

\* Courses listed in multiple areas shall not be certified in more than one area except for courses in *Languages Other Than English*, which can be certified in both areas 3B and 6A.



## IGETC 2016-2017 INFORMATION

**What is the Intersegmental General Education Transfer Curriculum certification plan?** The Intersegmental General Education Transfer Curriculum (IGETC) is a program of coursework that allows students to fulfill 37 units of lower-division general education requirements for either the UC or CSU system prior to transfer.

**What is IGETC certification?** IGETC Certification is the process used by Los Angeles Southwest College to verify the completion of the Intersegmental General Education Transfer Curriculum for transfer to either the University of California or the California State University system. In order to be fully certified by this college, students must complete the entire IGETC curriculum. Although not part of the IGETC, Los Angeles Southwest College will also certify the completion of the CSU US History, Constitution and American Ideals graduation requirement.

**What is the value of transferring with certification?** Completion of the IGETC requirements will allow a student to transfer from a California community college to a UC or CSU without the need, after transfer, to take additional lower division general education courses. At the discretion of the university granting the degree, the course may be counted as fulfilling this requirement and counted toward General Education.

**Must the entire IGETC program be completed in order for a student to be certified under IGETC?** Yes. All coursework applicable to the IGETC must be completed and certified prior to transfer in order for it to be accepted by the UC and CSU system. Certification for CSU must include completion of the oral communication requirement (COMM 101). For UC certification, the foreign language requirement must be satisfied.

**Is a minimum grade required in all courses used for IGETC certification?** Yes. Both the UC and CSU require a grade of "C" or better in all courses used for the IGETC. Up to 15 units of coursework in which a "credit" or "pass" is received may be certified, providing either is equivalent to a grade of "C" or better.

**What will happen if the IGETC is not completed prior to transferring to a UC or CSU campus?** If the IGETC is not completed prior to transfer, students will be subject to the lower-division transfer requirements of the campus to which they transfer. These requirements vary from campus to campus but may require that the student take additional general education classes.

**Do courses taken at another college count toward certification?** If courses taken at another college are being used towards certification, Los Angeles Southwest College will place the courses in the IGETC areas identified by the offering college. Courses taken at 4-year institutions must be equivalent to courses offered at Los Angeles Southwest College. These courses will be placed in the subject areas in which the comparable LASC courses fit into this IGETC pattern. Courses completed at foreign institutions are not acceptable except for certification of competence in a language other than English. Students using two years of high school foreign language to satisfy the UC "Language Other Than English" requirement (IGETC Area 6) must have official copies of high school transcripts on file. This requirement may also be met by providing official documentation showing satisfactory completion, with the equivalent of a "C" grade or better, of two years of formal schooling at the sixth grade level or higher at an institution where the language of instruction was not English. Exam results used to meet this requirement must be on file at Los Angeles Southwest College.

**When do students apply for certification?** Students should apply for IGETC certification at the end of their last semester; students should generally not request certification until all IGETC requirements have been completed. The last college attended completes the certification.

**Where do students apply for certification?** Students complete the IGETC certification form with a Counselor; the student is responsible for turning the certification form in to the Office of Admissions and Records.

**What do students do to notify the CSU or UC of the certification?** Students must complete the Transcript Request form in the Office of Admissions and Records, requesting the final transcript to be sent to their chosen CSU or UC. They must check the box "State College Certification/IGETC." The record of the areas of certification will then be listed on the transcript that is sent to the university.

**NOTE: Completion of IGETC is not the same as completing major preparatory coursework.**

Web Addresses of all Universities of California: [www.ucop.edu](http://www.ucop.edu) & [www.californiacolleges.edu](http://www.californiacolleges.edu) & [www.csumentor.edu](http://www.csumentor.edu)

Online UC applications and status checks: [www.universityofcalifornia.edu](http://www.universityofcalifornia.edu)

Individual UC Web Addresses:

**For further information, please see a LASC counselor.**

UC Berkeley: [www.berkeley.edu](http://www.berkeley.edu)

UC Riverside: [www.ucr.edu](http://www.ucr.edu)

UC Davis: [www.ucdavis.edu](http://www.ucdavis.edu)

UC Santa Cruz: [www.ucsc.edu](http://www.ucsc.edu)

UC Irvine: [www.uci.edu](http://www.uci.edu)

UC Santa Barbara: [www.ucsb.edu](http://www.ucsb.edu)

UC Los Angeles: [www.ucla.edu](http://www.ucla.edu)

UC San Diego: [www.ucsd.edu](http://www.ucsd.edu)

UC Merced: [www.ucmerced.edu](http://www.ucmerced.edu)

## OTHER SOUTHWEST INSTRUCTIONAL PROGRAMS

### Certificate Programs

Certificate programs offer concentrated study in areas directly applicable to many jobs and can add breadth and depth to existing knowledge and skills. Students enroll in these programs to:

- Acquire extensive practical background and skills
- Justify promotion
- Facilitate career change
- Provide meaningful documentation noting formal education in a specific field
- Benefit from the discipline of working toward a goal
- Examine a new field

Most programs do not require a university or college degree, but a minimum of 12 units must be completed at this institution, and all certificate courses must be completed with a grade of “C” or better. Many programs include special introductory courses for students at a beginning level; advanced classes usually have prerequisites which provide the necessary background information.

Students should consult a faculty advisor or counselor per their vocational/technical area of interest. Students may obtain a certificate application in the Counseling Office.

Students should review their applications with a counselor for approval. Upon signed approval, the Admissions Office will process the application.

After applications are processed, students will be notified to bring in picture identification in order to receive a certificate of completion. No certificates will be mailed.

### Petition for Certificate of Completion

This document is used to process a student’s record of course work to qualify for and to receive a Certificate of Achievement or Skill Certificate. All coursework must be completed or in progress at the time of filing a petition for Certificate of Completion.

In accordance with B.R. 6201.13, Certificates shall be awarded by the college where the majority of the certificate units were taken. Recipients of Certificates are honored at a ceremony separate from Commencement.





# INSTRUCTIONAL PROGRAMS

## Associate in Arts Degree at LASC

Requirements are:

- A. Complete a minimum of 21 units of LACCD GENERAL EDUCATION REQUIREMENTS,
- B. Complete REQUIRED COURSES earning a "C" or better in each course,
- C. Complete additional units chosen from RECOMMENDED ELECTIVES (where optioned),
- D. Complete a balance of degree-applicable electives, to total 60 units with a minimum of a 2.0 grade point average.

## Associates for Transfer Degree (ATD)

The Associate for Transfer Degree is intended for students who are planning to transfer to a California State University (CSU) institution into a Bachelors program. The Student is guaranteed admission to a CSU upon completion of this program. The intent of the Associate for Transfer Degree is to assist students in seamlessly transferring to CSU.

Senate Bill (SB) 1440 and the California Education Code (CEC) section 66746 require students seeking an Associate in Arts in English for Transfer Degree to:

- (1) Complete 60 semester units of 90-quarter units that are eligible for transfer to the California State University, including both of the following?
  - a. The Intersegmental General Education Transfer curriculum (IGETC) or the California State University General Education-Breadth Requirements
  - b. A minimum of 18 semester units or 27 quarter units in a major or area of emphasis, as determined by the community college district
  - c. Minimum 18 units in the major

(2) Obtainment of a minimum grade point average of 2.0. ADTs also require that students must earn a C or better in all courses required for the major area of emphasis. A "P" (Pass) grade is not an acceptable grade for courses in the major.

Students should meet with a counselor to determine the necessary course work to complete the general education requirements.



# ARTS & HUMANITIES

Cox Building, Room 520  
(323) 241-5418

[www.lasc.edu/students/departments/art-humanities/artdepartment.html](http://www.lasc.edu/students/departments/art-humanities/artdepartment.html)

Dr. Allison Moore, Department Chair

A degree in the Arts and Humanities prepares our students to open their minds and imaginations to fresh perspectives on the world, their communities and themselves. Discovery in the arts helps students to cultivate the creative contributions they have to share with the diversity of humanity. By studying the world's cultures, students expand their horizons and prepare themselves for an increasingly multicultural world; the study in philosophy helps students to analyze the fundamental questions about society and the universe. Our disciplines explore the ways in which people have articulated their understanding of themselves and the world.

The department offers courses in six subjects, with degree programs in five (5) areas. In addition the department supports an Interdisciplinary Studies (IDS) degree in the Arts and Humanities. Many of the courses in the Arts and Humanities serve the dual purpose of General Education subjects for transfer to major Colleges and Universities. With this in mind, Los Angeles Southwest College endorses the Los Angeles Community College District Board Rule (6201.14) on General Education:

Central to an Associate Degree, General Education is designed to introduce students to the variety of means through which people comprehend the modern world. It reflects the conviction of colleges that those who receive their degrees must possess in common certain basic principles, concepts, and methodologies both unique to and shared by the various disciplines. College educated persons should be able to use this knowledge when evaluating and appreciating the physical environment, the culture, and the society in which they live. Most importantly, General Education should lead to better self-understanding.

In keeping with the mission of Los Angeles Southwest College, General Education courses should also expand students' academic experiences that contribute to enrichment of life, affirmation of a diverse population, and promote life-long learning.

## Faculty

**Jonathan Bremen (2009)**

Instructor, Music  
B.A., Sonoma State University  
M.M., Indiana University  
D.M.A., University of Southern California  
[Bremenjd@lasc.edu](mailto:Bremenjd@lasc.edu)

**Yancy Duncan (2016)**

Assistant Professor, Communication Studies  
B.A., California State University, Los Angeles  
M.A., California State University, Los Angeles  
[duncanya@lasc.edu](mailto:duncanya@lasc.edu)

**Lauren Evans (2016)**

Instructor, Fine Arts  
B.F.A., University of Southern California  
M.F.A., University of Southern California  
[evansll@lasc.edu](mailto:evansll@lasc.edu)

**Voiza Greene (2012)**

Associate Professor, Speech Communication  
B.A., California State University, Los Angeles  
M.A., California State University, Los Angeles  
[greenevm@lasc.edu](mailto:greenevm@lasc.edu)

**Jonathon Pope-Evans (2016)**

Assistant Professor, Theater Arts  
B.F.A., William Carey College  
M.F.A., California Institute of the Arts  
[evansjp@lasc.edu](mailto:evansjp@lasc.edu)

**Katrina Taylor (2016)**

Assistant Professor, Communication Studies  
B.S., Bradley University  
M.F.A., University of Washington  
[taylorkl@lasc.edu](mailto:taylorkl@lasc.edu)



## ADJUNCT PROFESSORS

Alexander, A. ....	Music
Bartels, D. ....	Art
Brown, R.D. ....	Cinema
Bullock, C. ....	Theater
Cummings, R. ....	Music
Harrington, K. ....	Theater
Jackson, J. ....	Theater
Leonard, D. ....	Theater
Lewis, P. ....	Communications
McCants-Reed, D. ....	Communications, Law
McLeod, H. ....	Communications
Nichols, G. ....	Theater
Peters, S.L. ....	Philosophy
Sweeney, C.P. ....	Humanities
Vasquez, S. ....	Art
Wagner, G. ....	Cinema
Walker, D. ....	Communications
Wheeler, N. ....	Music
Wyatt, G. ....	Music
Young, E.L. ....	Humanities

## STAFF

Burch, Vanessa. ....	Piano Accompanist
Tippens, Traci. ....	Senior Secretary

## DISCIPLINES

- Art
- Communication Studies
- Humanities
- Music
- Philosophy
- Theatre Arts

## ASSOCIATE DEGREES

- Art
- Art: Option in Art History
- Communication Studies
- Communication Studies (AA-T)
- IDS: Arts & Humanities
- Music

- Studio Arts (AA-T)
- Theatre Arts
- Theatre Arts (AA-T)

### Associate in Arts Degree at LASC

Requirements are:

- Complete a minimum of 21 units of LACCD GENERAL EDUCATION REQUIREMENTS,
- Complete REQUIRED COURSES earning a "C" or better in each course,
- Complete additional units chosen from RECOMMENDED ELECTIVES (where optioned),
- Complete a balance of degree-applicable electives, to total 60 units with a minimum of a 2.0 grade point average.

### Transfer Students

Completing the Associate Degree does not necessarily meet the university admission requirements for transfer. If you would like to transfer to a university, early educational planning can make this goal achievable. For information regarding the requirements to transfer to a University of California (UC), or California State University (CSU) campus, please consult with a counselor.

### ASSOCIATE IN ARTS Art

Student Learning Outcome:

Upon completion of this program, students will:

- Use terminology appropriate to art appreciation, and analyze works of art to explain how visual works of art communicate within a cultural context.
- Analyze the composition, design, application of media, and iconography of art works.
- Explain what constitutes significant or major innovations by studying the evolution of style.
- Demonstrate application of color, the visual elements, space systems, and how to organize and present a resolved composition.

#### Required Courses:

	Units
ART 101	Survey of Art History I ..... 3
ART 102	Survey of Art History II ..... 3
ART 201	Drawing I ..... 3
ART 501	Beginning Two-Dimensional Design ..... 3
ART 502	Beginning Three-Dimensional Design ..... 3

#### PLUS 3 units from Recommended Electives:

ART 103	Art Appreciation I ..... 3
ART 104	Art Appreciation II ..... 3
ART 202	Drawing II ..... 3
ART 300	Introduction to Painting ..... 3
ART 307	Oil Painting I ..... 3

ART 308	Oil Painting II .....	3
ART 309	Oil Painting III .....	3
<b>TOTAL UNITS</b> .....		<b>18</b>

**ASSOCIATE IN ARTS**

**Art: Option in Art History**

Student Learning Outcome:

Upon completion of this program, students should be able to:

1. Use terminology appropriate to art appreciation, and analyze works of art to explain how visual works of art communicate within a cultural context.
2. Identify major works of art from pre-history to the early modern world.

<b>Required Courses:</b>		<b>Units</b>
ART 101	Survey of Art History I .....	3
ART 102	Survey of Art History II .....	3
ART 501	Beginning Two-Dimensional Design .....	3
OR		
ART 502	Beginning Three-Dimensional Design .....	3
ENGLISH 102	College Reading and Composition II .....	3
HUMAN 1	Cultural Patterns of Western Civilization .....	3

**PLUS 3 units from Recommended Electives:**

ART 103	Art Appreciation I .....	3
ART 104	Art Appreciation II .....	3
<b>TOTAL UNITS</b> .....		<b>18</b>

**ASSOCIATE IN ARTS**

**Communication Studies**

Student Learning Outcome:

Upon completion of this program, students should be able to:

1. Deliver an extemporaneous speech using documented sources.
2. Describe the international phonetic alphabet and its application to speech.

<b>Required Courses:</b>		<b>Units</b>
HUMAN 1	Cultural Patterns of Western Civilization .....	3
COMM 101	Oral Communication I .....	3
COMM 102	Oral Communication II .....	3
ENGLISH 102	College Reading and Composition II .....	3
THEATER 100	Introduction to the Theater .....	3

<b>Recommended Electives</b>		<b>Units</b>
ENGLISH 101	College Reading and Composition I .....	3
COMM 130	Introduction to Oral Interpretation of Literature .....	3
<b>TOTAL UNITS</b> .....		<b>18</b>

**ASSOCIATE IN ARTS**

**in Communication Studies for Transfer**

The Associate in Arts in Communication Studies for Transfer Degree is intended for students who are planning to transfer to a California State University (CSU) institution into the Communication Bachelors program. The Student is guaranteed admission to a CSU upon completion of this program. The Transfer Degree is designed to provide students with a Transfer Model Curriculum to study interdisciplinary,

critical study of technical development of Communication. Students will build a foundation for future creative, interpretive, analytical work and portfolios. The curriculum specifically prepares the students for upper division course work in Communication Studies.

**Required Course (s): (Complete 3 Units)**

COMM 101	Oral Communication I .....	3
----------	----------------------------	---

**List A: Select Two**

COMM 104	Argumentation .....	3
COMM 121	The Process of Interpersonal Communication .....	3
COMM 151	Small Group Communication .....	3

**List B: Select Two**

COMM 106	Forensics .....	3
COMM 122	Communication Across Cultures .....	3
COMM 130	Introduction to Oral Interpretation of Literature .....	3

**List C: Select One**

ANTH 102	Human Way of Life: Cultural Anthropology .....	3
PSYCH 1	General Psychology .....	3
SOC 1	Introduction to Sociology .....	3
ENGLISH 102	College Reading and Composition II .....	3
OR		
ENG 103	Composition and Critical Thinking .....	3
JOURNAL 101	Collecting and Writing News .....	3
OR		
JOURNAL 105	Mass Communication .....	3
<b>TOTAL UNITS</b> .....		<b>18</b>

\*Also any LIST A course not already used or any course articulated as lower division preparation in the Communication, Communication Studies major at a CSU.

\*Also any LIST A or B course not already used or any CSU transferable Communication Studies course.

**ASSOCIATE IN ARTS**

**Interdisciplinary Studies: Arts & Humanities**

**Option 1—Non-Transfer use LACCD GE**

**Option 2—Transfer use CSU-GE or IGETC**

Student Learning Outcome:

Upon completion of this program, students should be able to:

1. Identify art, music, and literature from pre-history to the early modern world.
2. Compare and contrast various presentation styles in art, music, and theater.

**Core Courses: (Complete 9 units) Units**

ART 101	Survey of Art History I .....	3
OR		
ART 103	Art Appreciation I .....	3
MUSIC 101	Fundamentals of Music .....	3
OR		
MUSIC 111	Music Appreciation I .....	3
HUMAN 1	Cultural Patterns of Western Civilization .....	3
THEATER 110	History of the World Theater .....	3
THEATER 270	Beginning Acting .....	3

**Additional Requirements: (Choose and complete 9 additional units)**



ASL 1	American Sign Language I	3
ASL 2	American Sign Language II	3
ASL 3	American Sign Language	3
ART 101	Survey of Art History I	3
ART 102	Survey of Art History II	3
ART 103	Art Appreciation I	3
ART 104	Art Appreciation II	3
ART 201	Drawing I	3
ART 300	Introduction to Painting	3
ART 501	Beginning Two-Dimensional Design	3
ENGLISH 127	Creative Writing	3
ENGLISH 211	Fiction	3
ENGLISH 212	Poetry	3
ENGLISH 213	Dramatic Literature	3
ENGLISH 218	Children's Literature	3
ENGLISH 234	African-American Literature I	3
ENGLISH 239	Women in Literature	3
FRENCH 1	Elementary French I	5
FRENCH 2	Elementary French II	5
HUMAN 1	Cultural Patterns of Western Civilization	3
HUMAN 2	Studies in Selected Cultures	3
HUMAN 6	Great People, Great Ages	3
HUMAN 31	People in Contemporary Society	3
MUSIC 101	Fundamentals of Music	3
MUSIC 111	Music Appreciation I	3
PHILOS 1	Introduction to Philosophy I	3
SPANISH 1	Elementary Spanish I	5
SPANISH 2	Elementary Spanish II	5
SPANISH 3	Intermediate Spanish I	5
SPANISH 4	Intermediate Spanish II	5
THEATER 100	Introduction to the Theater	3
THEATER 110	History of the World Theater	3
THEATER 233	Play Production	3
THEATER 240	Voice and Articulation for Theater	3
THEATER 270	Beginning Acting	3
THEATER 271	Intermediate Acting	2
THEATER 300	Introduction to Stage Craft	3
<b>TOTAL UNITS</b>		<b>18</b>

### ASSOCIATE IN ARTS Music

Student Learning Outcome:

Upon completion of this program, students should be able to:

1. Accurately (90%) analyze diatonic chord progressions using roman numerals.
2. Aurally recognize musical works and comment appropriately on musical characteristics, genre, form, social significance, historical context and production methods.
3. Identify and perform with proper fingering the major and minor scales and diatonic chord progressions.

Required Courses:	Units	
MUSIC 101	Fundamentals of Music	3
MUSIC 111	Music Appreciation I	3
MUSIC 321	Elementary Piano I	2
MUSIC 322	Elementary Piano II	2
MUSIC 323	Elementary Piano III	2
OR		
MUSIC 413	Elementary Voice III	2
MUSIC 411	Elementary Voice	2
MUSIC 412	Elementary Voice II	2

### PLUS 8 units from Recommended Electives:

MUSIC 201	Harmony I	3
MUSIC 202	Harmony II	3
MUSIC 323	Elementary Piano III	2
MUSIC 324	Elementary Piano IV	2
MUSIC 413	Elementary Voice III	2
MUSIC 414	Elementary Voice IV	2
<b>TOTAL UNITS</b>		<b>24</b>

### ASSOCIATE IN ARTS in Studio Arts for Transfer

The Associate in Arts in Studio Arts for Transfer Degree is intended for students who are planning to transfer to a California State University (CSU) institution into the Studio Arts Bachelors program. The Student is guaranteed admission to a CSU upon completion of this program. The Associate in Arts in Studio Arts for Transfer Degree is designed to provide students with a Transfer Model Curriculum which offers a broad range of courses in the visual arts designed for the student who is planning to transfer to a CSU. The study of Studio Arts is an interdisciplinary, critical study of technical development, as well as the foundation for all studio based courses. Students explore the various areas of studio art to build a foundation for future creative, interpretive, analytical work and portfolios.

Required Courses:	Units	
ART 102	Survey of Art History II	3
ART 201	Drawing I	3
ART 501	Beginning Two-Dimensional Design	3
ART 502	Beginning Three-Dimensional Design	3

### List A: Select One

ART 101	Survey of Art History I	3
ARTHIST 130	History of Asian Art	3
ARTHIST 140	Arts of Africa, Oceania and Ancient America	3

### List B: Select Three

ART 202	Drawing II	3
ART 204	Life Drawing	3
ART 213	Color Theory	3
ART 300	Introduction to Painting	3
<b>TOTAL UNITS</b>		<b>24</b>

### ASSOCIATE IN ARTS Theater Arts

Student Learning Outcome:

Upon completion of this program, students should be able to:

1. Select, prepare, and perform a character from monologues, scenes, and plays with emphasis on styles, vocal patterns, and differentiate between the theatrical genres.
2. Execute the technical functions involved with production that include lights, sounds, and the development and use of props.
3. Write a one act play. In that process, identify the genre of their work: comedy, drama, etc. Their story will be based



on a self-developed high concept treatment sentence and step outline.

<b>Required Courses:</b>	<b>Units</b>
THEATER 100 Introduction to the Theater .....	3
THEATER 110 History of the World Theater .....	3
THEATER 130 Playwriting .....	3
THEATER 233 Play Production .....	3
THEATER 240 Voice and Articulation for the Theater.....	3
THEATER 270 Beginning Acting .....	3
THEATER 271 Intermediate Acting .....	3
<b>TOTAL UNITS</b> .....	<b>21</b>

**ASSOCIATE IN ARTS  
in Theatre Arts for Transfer**

The Associate in Arts in Theatre Arts for Transfer Degree is intended for students who are planning to transfer to a California State University (CSU) institution into the Theater Bachelors program. The Student is guaranteed admission to a CSU upon completion of this program. The Transfer Degree is designed to provide students with a Transfer Model Curriculum is designed to provide general education and lower division major preparation for students interested in transferring to CSUs. The study is an interdisciplinary, critical study of technical development, as well as the foundation for all Theater Arts courses. Students explore the various areas of Theater Arts to build a foundation for future creative, interpretive, analytical work and portfolios. The Associate of Arts in Theater for Transfer Degree is designed to prepare students for transfer into the CSU

**Required Courses: Complete 9 Units**

THEATER 100 Introduction to the Theater .....	3
OR	
THEATER 110 History of the World Theater .....	3
THEATER 270 Beginning Acting .....	3
THEATER 291 Rehearsals and Performances .....	3
OR	
THEATER 342 Technical Stage Production Lab .....	3

**List A: Select Three**

THEATER 114 Script Analysis for Performance, Production and Appreciation .....	3
THEATER 271 Intermediate Acting .....	3
THEATER 310 Introduction to Theatrical Lighting.....	3
THEATER 315 Introduction to Theatrical Scenic Design.....	3
THEATER 405 Costume Design .....	3
<b>TOTAL UNITS</b> .....	<b>18</b>





# BEHAVIORAL & SOCIAL SCIENCES

School of Behavioral and Social Science Building, Room 204  
 (323) 241- 5539  
[www.lasc.edu/students/departments/bssd/index.html](http://www.lasc.edu/students/departments/bssd/index.html)

Rasheed Saafir, Department Chair

We explore how human beings and animals are studied through science, observation and experimental methods. Areas of focus such as anthropology, psychology, and sociology give us greater understanding of human interactions. The Behavioral and Social Sciences Department offers various student-led clubs and programs designed to facilitate student involvement, participation and extended learning.



## Faculty

**Leonard E. Apenahier (1996)**  
 Associate Professor, Psychology  
 B.S., University of Oregon  
 M.A., Pepperdine University, M.S., Vanderbilt University  
 Ph.D., Howard University  
[apenahale@lasc.edu](mailto:apenahale@lasc.edu)

**Travis A. DuBry (2016)**  
 Assistant Professor, Anthropology  
 B.S. University of California, Riverside  
 M.A. University of California, Riverside  
 Ph.D. University of California, Riverside  
[dubryta@lasc.edu](mailto:dubryta@lasc.edu)

**Tamura Howard (2008)**  
 Instructor, Political Science  
 B.A., California State University, Long Beach  
 M.A., University of California, Los Angeles  
 Ph.D., University of California, Los Angeles  
[howardtd@lasc.edu](mailto:howardtd@lasc.edu)

**Maisha Jones (2015)**  
 Associate Professor, Sociology  
 M.A., California State University at Dominguez Hills  
[jonesmn@lasc.edu](mailto:jonesmn@lasc.edu)

**Phillip Jones-Thomas (1979)**  
 Professor, English & American Sign Language  
 B.A., University of Kansas  
 M.A., University of Illinois  
[jonespa@lasc.edu](mailto:jonespa@lasc.edu)

**Sandra Lee (1999)**  
 Professor, Psychology  
 AFT Chapter President  
 B.A., University of California, Los Angeles  
 M.Ed., University of Louisville, M.A., University of Louisville  
 Ph.D., University of Louisville  
[lees@lasc.edu](mailto:lees@lasc.edu)

**Wonda Powell (1979)**  
 Professor, History, Business  
 B.S., University of Michigan  
 M.A., University of California, Los Angeles  
[powellwa@lasc.edu](mailto:powellwa@lasc.edu)

**Lance A. Robert (2015)**  
 Instructor, Political Science  
 B.A., University of California, Santa Barbara  
 MPA, California State University, Long Beach  
 DPA, Capella University  
[robertla@lasc.edu](mailto:robertla@lasc.edu)

**Rasheed Saafir (2014)**  
 Instructor, Administration of Justice  
 B.A., California State University of Fresno  
 M.P.A., California State University of Dominguez Hills  
[saffirrf@lasc.edu](mailto:saffirrf@lasc.edu)

**Kristine Wright (2008)**  
 Instructor, Sociology  
 B.A., University of California, Los Angeles  
 Ph.D., University of California, Irvine  
[wrightkm@lasc.edu](mailto:wrightkm@lasc.edu)

## ADJUNCT PROFESSORS

Adkins-Jackson, P.....	Anthropology
Atkins, S.....	Psychology
Austin, N.....	History
Ayers, M.....	Administration of Justice
Barlow, C.....	Administration of Justice
Blagdon, O.....	American Sign Language
Blocker, B.....	Administration of Justice
Campbell, A.....	Administration of Justice
Claybourne, DI.....	History
Corneal, A.....	American Sign Language
Cranon-Charles, A.....	Political Science
Crenshaw, G.....	Psychology
Cunin Borer, M.....	Anthropology
Diaz, J.....	History
Egipciano, M.....	Psychology
Embry, G.....	Psychology
Ford, B.....	Psychology
Harris, M.....	Sociology
Haynes-Burton, S.....	Psychology
Horne, D.....	Political Science
Jackson, T.....	Psychology
Katz, S.....	Administration of Justice
Lavender, L.....	Administration of Justice
Lee, C.....	Political Science
Lee, J.....	Sociology
Lewis, M.....	Administration of Justice
Malone, M.....	Education
Mattson, G.....	Anthropology
McNamee, D.....	Psychology
Moreno, E.....	Sociology
Porter, P.....	Sociology
Rhymes, R.....	Sociology
Scott-Stafford, J.....	Political Science
Shaffer, C.....	Administration of Justice
Soto, J.....	History
Strauss, E.....	Anthropology
Toussant-Jackson, A.....	Political Science
Umoja, A.....	Political Science
Walker, M.....	Anthropology
Ward, H.....	American Sign Language
White, S.....	Sociology
Ybarra D.....	History
Zanders, C.....	Psychology

## STAFF

Venable, Aynjellia..... Secretary

## DISCIPLINES

- Administration of Justice
- American Sign Language
- Anthropology
- Education

- History
- Political Science
- Psychology
- Sociology

## ASSOCIATE DEGREES

- Administration of Justice
- Administration of Justice AS-T
- Anthropology
- Anthropology AA-T
- History
- History AA-T
- IDS: Behavioral & Social Science
- Liberal Arts: Administration of Justice
- Liberal Arts: Psychology of Substance Abuse
- Liberal Studies: Teacher Preparation
- Pan American Studies
- Political Science
- Political Science AA-T
- Psychology
- Psychology AA-T
- Sociology
- Sociology AA-T

## CERTIFICATES OF ACHIEVEMENTS

- Administration of Justice
- Chemical Dependency Counselor

## SKILL CERTIFICATES

- Chemical Dependency Specialist in Criminal Justice
- Fingerprinting
- Recovery Specialist
- Social Services
- Teacher Assistant





## Associate in Arts Degree at LASC

Requirements are:

- Complete a minimum of 21 units of LACCD GENERAL EDUCATION REQUIREMENTS,
- Complete REQUIRED COURSES earning a "C" or better in each course,
- Complete additional units chosen from RECOMMENDED ELECTIVES (where optioned),
- Complete a balance of degree-applicable electives, to total 60 units with a minimum of a 2.0 grade point average.

### Transfer Students

Completing the Associate Degree does not necessarily meet the university admission requirements for transfer. If you would like to transfer to a university, early educational planning can make this goal achievable. For information regarding the requirements to transfer to a University of California (UC), or California State University (CSU) campus, please consult with a counselor.

## ASSOCIATE IN ARTS Administration of Justice

Student Learning Outcomes:

Upon completion of this program, students will:

- Analyze the interrelationships between the courts, law enforcement, and corrections.
- Demonstrate the sequence of events necessary in determining admissibility or suppression of evidence.
- Analyze basic legal definitions of criminal justice law.
- Compare and contrast information obtained to maintain a balanced perception of law enforcement.

Required Courses:	Units
ADM JUS 1 Introduction to Administration of Justice	3
ADM JUS 2 Concepts of Criminal Law	3
ADM JUS 3 Legal Aspects of Evidence	3
ADM JUS 4 Principles and Procedures of the Justice System	3
ADM JUS 5 Criminal Investigation	3
ADM JUS 6 Patrol Procedures	3
ADM JUS 14 Report Writing for Peace Officers	3
ADM JUS 67 Community Relations I	3
ADM JUS 310 FIELD WORK I	3
<b>TOTAL UNITS</b>	<b>27</b>

Recommended Electives:	Units
ADM JUS 8 Juvenile Procedures	3
ADM JUS 16 Recruitment Selection Process	3
ADM JUS 62 Fingerprint Classification	3
ADM JUS 63 Introduction to Criminology	3
ADM JUS 73 Law & Minority Groups	3
ADM JUS 75 Introduction to Corrections	3
ADM JUS 83 Introduction to Security	3
MATH 227 Statistics	4
MATH 235 Finite Mathematics	5
OR	

PHILOS 8	Deductive Logic	3
POL SCI 1	The Government of the United States	3
PSYCH 1	General Psychology I	3
SOC 1	Introduction to Sociology	3
SPAN 14	Spanish for Public Service Personnel	3

## ASSOCIATE IN SCIENCE in Administration of Justice for Transfer

The Associate in Science in Administration of Justice for Transfer Degree is intended for students who are planning to transfer to a California State University (CSU) institution into the Criminal Justice Bachelors program. The Student is guaranteed admission to a CSU upon completion of this program. The Transfer Degree is designed to provide students with a Transfer Model Curriculum that prepares students for a variety of careers in the criminal justice system. Courses within the program acquaint students with the American Justice system, crime causes, the role of law enforcement, roles of administration of justice practitioners, procedural and constitutional rights of defendants, legal defenses, criminal courtroom procedure, evidence procedures, juvenile procedures, and misdemeanor and felony violations of criminal law.

The intent of the Associate in Science in Administration of Justice for Transfer Degree is to assist students in seamlessly transferring to CSU.

Senate Bill (SB) 1440 and the California Education Code (CEC) section 66746 require students seeking an Associate in Science in Administration of Justice for Transfer Degree:

- Complete 60 semester units of 90-quarter units that are eligible for transfer to the California State University, including both of the following?
  - The Intersegmental General Education Transfer curriculum (IGETC) or the California State University General Education-Breadth Requirements
  - A minimum of 18 semester units or 27 quarter units in a major or area of emphasis, as determined by the community college district.

(2) Obtainment of a minimum grade point average of 2.0. ADTs also require that students must earn a C or better in all courses required for the major area of emphasis. A "P" (Pass) grade is not an acceptable grade for courses in the major.

Students should meet with a counselor to determine the necessary course work to complete the general education requirements. Student Learning Outcomes:

Upon completion of this program, students will:

- Analyze the interrelationships between the courts, law enforcement, and corrections.
- Demonstrate the sequence of events necessary in determining admissibility or suppression of evidence.
- Analyze basic legal definitions of criminal justice law.
- Compare and contrast information obtained to maintain a balanced perception of law enforcement.

Required Courses:	Units
ADM JUS 1 Introduction to Administration Of Justice	3
ADM JUS 2 Concepts of Criminal Law	3

**List A: Two Courses (6 units)**  
ADM JUS 3 Legal Aspects of Evidence 3

ADM JUS 5	Criminal Investigation .....	3
ADM JUS 67	Community Relations .....	3
ADM JUS 75	Introduction to Corrections .....	3
ADM JUS 8	Juvenile Procedures .....	3

**List B: Two Courses (minimum of 6 units)**

SOC 1	Introduction to Sociology .....	3
MATH 227	Statistics.....	4
PSYCH 1	General Psychology I .....	3
<b>TOTAL UNITS</b>	.....	<b>18-19</b>

**ASSOCIATE IN ARTS  
Anthropology**

Student Learning Outcome:

Upon completion of this program, students will:

1. Apply a holistic anthropological perspective to the analysis of local, national, and global human issues.
2. Analyze the role that culture plays in human behavior, biology, evolution, and ways of life.
3. Develop an awareness of and respect for human diversity.

<b>Required Courses:</b>	<b>Units</b>
ANTHRO 101 Human Biological Evolution .....	3
ANTHRO 102 Human Ways of Life: Cultural Anthropology .....	3
GEOG 1 Physical Geography .....	3
HISTORY 1 Introduction to Western Civilization I .....	3
HISTORY 2 Introduction to Western Civilization II .....	3
SOC 1 Introduction to Sociology .....	3
<b>TOTAL UNITS</b> .....	<b>21</b>

**PLUS 3 units from Recommended Electives:**

ANTHRO 104 Human Language and Communication .....	3
ANTHRO 121 Anthropology of Religion, Magic, and Witchcraft .....	3
ANTHRO 133 Peoples and Cultures of Africa .....	3
HUMAN 1 Cultural Patterns of Western Civilization .....	3
POL SCI 1 The Government of the United States .....	3
PSYCH 1 General Psychology I .....	3
SOC 2 American Social Problems .....	3

**ASSOCIATE IN ARTS  
in Anthropology for Transfer**

The intent of the Associate in Arts in Anthropology for Transfer Degree is to assist students in seamlessly transferring to CSU into the Anthropology Bachelors program. Senate Bill (SB) 1440 and the California Education Code (CEC) section 66746 require students seeking an Associate in Arts in Anthropology for Transfer Degree to:

- (1) Complete 60 semester units of 90-quarter units that are eligible for transfer to the California State University, including both of the following?
  - a. The Intersegmental General Education Transfer curriculum (IGETC) or the California State University General Education-Breadth Requirements
  - b. A minimum of 18 semester units or 27 quarter units in a major or area of emphasis, as determined by the community college district.
- (2) Obtainment of a minimum grade point average of 2.0. ADTs also require that students must earn a C or better in all courses required for the major area of emphasis. A "P" (Pass) grade is not an acceptable grade for courses in the major.

Student Learning Outcome:

Upon completion of this program, students will:

1. Apply a holistic anthropological perspective to the analysis of local, national, and global human issues.
2. Analyze the role that culture plays in human behavior, biology, evolution, and ways of life.
3. Develop an awareness of and respect for human diversity.

**Required Courses: Units**

ANTHRO 101 Human Biological Evolution .....	3
ANTHRO 102 Human Ways of Life: Cultural Anthropology .....	3
ANTHRO 103 Archaeology: Reconstructing the Human Past .....	3

**List A: Select One**

ANTHRO 121 Anthropology of Religion, Magic and Witchcraft .....	3
MATH 227 Statistics .....	4

**List B Area 1: Select One**

PSYCH 92 Psychological Research .....	5
SOC 4 Sociological Analysis .....	3

**List B Area 2: Required**

GEOLOGY 1 Physical Geology .....	3
GEOLOGY 6 Physical Geology Laboratory .....	2

**List C: Select One**

SOC 1 Introduction to Sociology .....	3
SOC 11 Ethnic & Racial Minorities in the United States .....	3
<b>TOTAL UNITS</b> .....	<b>18-21</b>

**ASSOCIATE IN ARTS  
History**

Student Learning Outcome:

Upon completion of this program, students will:

1. Compare, contrast and analyze past events to interpolate the impact of these events on the present political, cultural, legal, economic and social precedents.
2. Write a comprehensive essay on the importance of the history of a particular facet to the embedded understanding of today's problems.

**Required Courses: Units**

HISTORY 1 Introduction to Western Civilization I .....	3
HISTORY 2 Introduction to Western Civilization II .....	3
HISTORY 5 History of the Americas I .....	3
HISTORY 11 Political and Social History of the United States I .....	3
OR	
HISTORY 41 The African-American in the History of the United States I .....	3
OR	
HISTORY 43 The Mexican-American in the History of the United States I .....	3
HISTORY 12 Political and Social History of the United States II .....	3
OR	
HISTORY 42 The African-American in the History of the United States II .....	3



HISTORY 52	The Role of Women in the History of the United States	3
TOTAL UNITS		18

**ASSOCIATE IN ARTS  
in History for Transfer**

The Associate in Arts in History for Transfer is intended for students who are planning to transfer to a California State University (CSU) institution into the History Bachelors program. The Student is guaranteed admission to a CSU upon completion of this program. The program is designed to develop critical thinking and rationale. The purpose of this program is to understand the complex institutional structure of United States of America.

The Associate in Arts in History for Transfer requirements include: (1) completion of 60 CSU transferable units, including the minimum 18-27 units in the major and the completion of either IGETC or CSU GE; (2) a minimum GPA of 2.0. (3) A grade of "C" or better in all courses required for the major or area of emphasis. Students should meet with a counselor to determine the necessary course work to complete the general education requirements. Program Objectives:

1. The program is designed to develop critical thinking and rationale;
2. The purpose of this program is to understand the complex institutional structure of United States of America.

Required Courses:	Units
HISTORY 11 Political and Social History of the United States I	3
HISTORY 12 Political and Social History of the United States I I	3

**Select two courses**

HISTORY 1	Introduction to Western Civilization I	3
HISTORY 2	Introduction to Western Civilization II	3

**Select one courses**

HISTORY 5	History of the Americas I	3
SPANISH 1	Elementary Spanish 1	5
SPANISH 2	Elementary Spanish 2	5

**Select one courses**

HISTORY 52	The Role of Women in the History of the United States	3
TOTAL UNITS		18 –20

**ASSOCIATE IN ARTS  
IDS: Behavioral & Social Science**

**Option 1—Non-Transfer use LACCD GE**

**Option 2—Transfer use CSU-GE or IGETC**

Student Learning Outcome:

Upon completion of this program, students will:

1. Describe the goals of psychology as a science.
2. List, describe, and explain the major theoretical viewpoints in psychology.
3. List and describe major research methods utilized in psychology.

**Core Courses: (Choose and complete 9 units)**

HISTORY 11	Political and Social History of the United States I	3
OR		
HISTORY 12	Political and Social History of the United States II	3
OR		
HISTORY 41	The African-American in the History of the United States I.	3
OR		
HISTORY 42	The African-American in the History of the United States II	3
OR		
HISTORY 43	The Mexican-American in the History of the United States	3
POL SCI 1	The Government of the United States	3
PSYCH 1	General Psychology I	3
SOC 1	Introduction to Sociology	3

**Additional Requirements: (Choose and complete 9 additional units)**

ADM JUS 1	Introduction to Administration of Justice	3
ANTHRO 102	Human Ways of Life: Cultural Anthropology	3
ANTHRO 133	Peoples and Culture of Africa	3
BUS 1	Introduction to Business	3
BUS 5	Business Law I	3
BUS 6	Business Law II	3
CH DEV 1	Child Growth and Development	3
ECON 1	Principles of Economics I	3
ECON 2	Principles of Economics II	3
GEOG 2	Cultural Elements of Geography	3
HISTORY 1	Introduction to Western Civilization I	3
HISTORY 2	Introduction to Western Civilization II	3
HISTORY 3	History of England and Great Britain I	3
HISTORY 5	History of the Americas I	3
HISTORY 11	Political and Social History of the United States I	3
HISTORY 12	Political and Social History of the United States II	3
HISTORY 37	History of African Civilization	3
HISTORY 41	The African-American in the History of the United States I	3
HISTORY 42	The African-American in the History of the United States II	3
HISTORY 43	The Mexican-American in the History of the United States I	3
HISTORY 52	The Role of Women in the History of the United States	3
LAW 3	Civil Rights and the Law	3
MATH 227	Introductory Statistics	4
POL SCI 1	The Government of the United States	3
POL SCI 2	Modern World Governments	3
POL SCI 7	Contemporary World Affairs	3
POL SCI 9	Governments and Politics in Africa	3
PSYCH 1	General Psychology I	3
PSYCH 11	Child Psychology	3
PSYCH 14	Abnormal Psychology	3
PSYCH 41	Life-Span Psychology: From Infancy to Old Age	3
SOC 1	Introduction to Sociology	3
SOC 2	American Social Problems	3
SOC 11	Ethnic & Racial Minorities in the United States	3
SOC 12	Marriage and Family Life	3
TOTAL UNITS		18

**ASSOCIATE IN ARTS**  
**Liberal Arts: Administration of Justice**

Student Learning Outcome:

Upon completion of this program, students will:

1. Analyze the interrelationships between the courts, law enforcement, and corrections.
2. Demonstrate the sequence of events necessary in determining admissibility or suppression of evidence.
3. Analyze basic legal definitions of criminal justice law.
4. Compare and contrast information obtained to maintain a balanced perception of law enforcement.

**Core Courses (Complete 12 units):**

ADM JUS 1	Introduction to Administration of Justice	3
ADM JUS 2	Concepts of Criminal Law	3
ADM JUS 3	Legal Aspects of Evidence	3
ADM JUS 5	Criminal Investigation	3

**Additional Requirements (Choose and complete 6 additional units):**

ADM JUS 4	Principles and Procedures of the Justice System	3
ADM JUS 6	Patrol Procedures	3
ADM JUS 14	Report Writing for Peace Officers	3
ADM JUS 62	Fingerprint Classification	3
ADM JUS 67	Community Relations I	3
ADM JUS 73	Law & Minority Groups	3
ADM JUS 75	Introduction to Corrections	3
<b>TOTAL UNITS</b>		<b>18</b>

**ASSOCIATE IN ARTS**  
**Liberal Arts: Psychology of Substance Abuse**

Student Learning Outcome:

Upon completion of this program, students will:

1. Describe the goals of psychology as a science.
2. List, describe, and explain the major theoretical viewpoints in psychology.
3. List and describe major research methods utilized in psychology.
4. Discuss and describe the intake/initial interviewing process in a clinical setting.
5. Discuss and describe the treatment planning process in a clinical setting.

**Core Courses: (Choose and complete 18 units)**

PSYCH 1	General Psychology I	3
PSYCH 14	Abnormal Psychology	3
PSYCH 43	Principles of Group Dynamics I	3
PSYCH 63	Alcohol/Drug Studies: Prevention and Education	3
PSYCH 64	Introduction to Drug and Alcohol Abuse	3
PSYCH 65	Chemical Dependency: Intervention, Treatment and Recovery	3
PSYCH 67	Counseling Techniques for the Chemically Addicted	3
<b>TOTAL UNITS</b>		<b>18</b>

**ASSOCIATE IN ARTS**  
**Liberal Studies: Teacher Preparation**

Student Learning Outcome:

Upon completion of this program, students will:

1. Use language (oral and written) and non-verbal modes of communication appropriate to the audience and purpose.
2. Use critical thinking and computational skills to analyze, synthesize, and evaluate ideas and information.
3. Utilize research skills necessary to achieve educational, professional, and personal objectives.
4. Demonstrate sensitivity to and respect for others and participate actively in group and civic decision making.
5. Demonstrate practices that promote physical, mental, and emotional well-being.

**Core Courses: (Choose and complete 18 units)**

ART 103	Art Appreciation I	3
BIOLOGY 3	Introduction to Biology	4
CH DEV 1	Child Growth and Development	3
CHEM 51	Fundamentals of Chemistry I	5
COMM 101	Oral Communication I	3
ENGLISH 101	College Reading and Composition I	3
ENGLISH 102	College Reading and Composition II	3
ENGLISH 103	Composition and Critical Thinking	3
GEOLOGY 1	Physical Geology	3
GEOLOGY 6	Physical Geology Laboratory	2
HEALTH 11	Principles of Healthful Living	3
HISTORY 11	Political and Social History of the United States I	3
OR		
HISTORY 12	Political and Social History of the United States II	3
MATH 215	Principles of Math I	3
MATH 216	Principles of Math II	3
MATH 227	Introductory Statistics	4
MUSIC 101	Fundamentals of Music	3
PHYS SC 1	Physical Science I	3
PHYS SC 14	Physical Science Laboratory	1
POL SCI 1	The Government of the United States	3
<b>TOTAL UNITS</b>		<b>18</b>

**ASSOCIATE IN ARTS**  
**Pan American Studies**

Student Learning Outcome:

Upon completion of this program, students will:

1. Analyze the important contributions of different cultures to the development of America as a unique entity that has global and international implications.
2. Analyze the globalization process in social, political, historical, economic and cultural areas.

**Required Courses:**

		<b>Units</b>
HISTORY 5	Latin American History I	3
HISTORY 41	The African-American in the History of the United States I	3
HISTORY 42	The African-American in the History of the United States II	3
HISTORY 43	The Mexican-American in the History of the United States	3
HISTORY 52	The Role of Women in the History of the United States	3



POL SCI 7	Contemporary World Affairs .....	3
SOC 11	Ethnic and Racial Minorities in the United States .....	3
	<b>TOTAL UNITS</b> .....	<b>21</b>

**ASSOCIATE IN ARTS  
Political Science**

Student Learning Outcome:

Upon completion of this program, students will:

1. Demonstrate a basic knowledge of political institutions and processes of American government.
2. Prepare a research paper that analyzes the impact of important political events on the prevailing political culture of a country.

<b>Required Courses:</b>		<b>Units</b>
HISTORY 1	Introduction to Western Civilization I .....	3
HISTORY 2	Introduction to Western Civilization II .....	3
POL SCI 1	The Government of the United States .....	3
POL SCI 2	Modern World Governments.....	3
POL SCI 7	Contemporary World Affairs .....	3
POL SCI 9	Governments and Politics in Africa .....	3
	<b>TOTAL UNITS</b> .....	<b>18</b>

**ASSOCIATE IN ARTS  
in Political Science for Transfer**

The Associate in Arts in Political Science for Transfer Degree is intended for students who are planning to transfer to a California State University (CSU) institution into the Political Science Bachelors program. The Student is guaranteed admission to a CSU upon completion of this program. The Transfer Degree is designed to provide students with a Transfer Model Curriculum to introduce students to the study of the acquisition and use of public power and authority. The courses are for the student interested in learning about American Government and different political cultures in the world.

The intent of the Associate in Arts in Political Science for Transfer Degree is to assist students in seamlessly transferring to CSU. Senate Bill (SB) 1440 and the California Education Code (CEC) section 66746 require students seeking an Associate in Arts in Political Science for Transfer for Transfer Degree to:

- (1) Complete 60 semester units of 90-quarter units that are eligible for transfer to the California State University, including both of the following?
  - a. The Intersegmental General Education Transfer curriculum (IGETC) or the California State University General Education-Breadth Requirements
  - b. A minimum of 18 semester units or 27 quarter units in a major or area of emphasis, as determined by the community college district.
- (2) Obtainment of a minimum grade point average of 2.0. ADTs also require that students must earn a C or better in all courses required for the major area of emphasis. A "P" (Pass) grade is not an acceptable grade for courses in the major.

Students should meet with a counselor to determine the necessary course work to complete the general education requirements. Program Objectives:

1. To introduce students to the study of the acquisition and use of public power and authority.

2. The courses are for the student interested in learning about American Government and different political cultures in the world.

<b>Required Courses:</b>		<b>Units</b>
POL SCI 1	The Government of the United States .....	3

Select three courses:

POL SCI 2	Modern World Governments .....	3
POL SCI 5	The History of Western Political Thought .....	3
POL SCI 7	Contemporary World Affairs .....	3
POL SCI 50	Introduction to Research in Political Science .....	3

Select two courses:

POL SCI 9	Governments and Politics in Africa .....	3
POL SCI 20	Race and Ethnicity in Politics .....	3
	<b>TOTAL UNITS</b> .....	<b>18</b>

**ASSOCIATE IN ARTS  
Psychology**

Student Learning Outcome:

Upon completion of this program, students will:

1. Describe the goals of psychology as a science.
2. List, describe, and explain theoretical viewpoints in psychology.
3. List and describe major research methods utilized in psychology.

<b>Required Courses:</b>		<b>Units</b>
ANTHRO 102	Human Ways of Life: Cultural Anthropology .....	3
BIOLOGY 3	Introduction to Biology .....	4
PSYCH 1	General Psychology I .....	3
PSYCH 2	Biological Psychology .....	3
PSYCH 3	Personality and Social Development .....	3
OR		
PSYCH 11	Child Psychology .....	3
PSYCH 14	Abnormal Psychology .....	3
	<b>TOTAL UNITS</b> .....	<b>19</b>

**ASSOCIATE IN ARTS  
in Psychology for Transfer**

The Associate in Arts in Psychology for Transfer Degree is intended for students who are planning to transfer to a California State University (CSU) institution into the Psychology Bachelors program. The Student is guaranteed admission to a CSU upon completion of this program. The Transfer Degree is designed to provide students with a Transfer Model Curriculum to provide skills in Psychology, Biology, Sociology, statistics, research, multidisciplinary studies, child and adult development and most other social science disciplines.

The intent of the Associate in Arts in Psychology for Transfer Degree is to assist students in seamlessly transferring to CSU. Senate Bill (SB) 1440 and the California Education Code (CEC) section 66746 require students seeking an Associate in Arts in Psychology for Transfer Degree to:

- (1) Complete 60 semester units of 90-quarter units that are eligible for transfer to the California State University, including both of the following?
  - a. The Intersegmental General Education Transfer curriculum (IGETC) or the California State University General Education-

**Breadth Requirements**

b. A minimum of 18 semester units or 27 quarter units in a major or area of emphasis, as determined by the community college district.

(2) Obtainment of a minimum grade point average of 2.0. ADTs also require that students must earn a C or better in all courses required for the major area of emphasis. A "P" (Pass) grade is not an acceptable grade for courses in the major. Students should meet with a counselor to determine the necessary course work to complete the general education requirements.

**Student Learning Outcome:**

Upon completion of this program, students will:

1. Provide skills in psychology, biology, sociology, statistics, research, multidisciplinary studies, child and adult development and most other social science disciplines.

<b>Required Courses:</b>		<b>Units</b>
MATH 227	Statistics .....	4
PSYCH 1	General Psychology I .....	3
PSYCH 91	Statistics for Psychology .....	4
OR		
PSYCH 92	Psychological Research Methods .....	5
PSYCH 2	Biological Psychology .....	3
PSYCH 41	Life-Span Psychology: From Infancy To Old Age .....	3
OR		
PSYCH 3	Personality And Social Development .....	3
OR		
PSYCH 11	Child Psychology .....	3
<b>TOTAL UNITS</b> .....		<b>20-21</b>

**ASSOCIATE IN ARTS  
Sociology**

**Student Learning Outcome:**

Upon completion of this program, students will:

1. Demonstrate an understanding of the major theoretical perspectives in sociology in historical and socio-cultural contexts.
2. Give examples of the major properties of sociology research.

<b>Required Courses:</b>		<b>Units</b>
SOC 1	Introduction to Sociology .....	3
SOC 2	American Social Problems .....	3
SOC 11	Ethnic & Racial Minorities in the United States .....	3
SOC 12	Marriage and Family Life .....	3
<b>Plus 6 units from the following list Electives:</b>		
SOC 7	Juvenile Delinquency .....	3
SOC 19	Introduction to the Social Services .....	3
SOC 20	Directed Practice in Social Welfare .....	3
SOC 23	Issues of Manhood in US Society .....	3
SOC 45	Sociology of Media and Popular Culture: Examining Hip Hop .....	3
<b>TOTAL UNITS</b> .....		<b>18</b>

**ASSOCIATE IN ARTS  
in Sociology for Transfer**

The Associate in Arts in Sociology for Transfer Degree is intended

for students who are planning to transfer to a California State University (CSU) institution into the Sociology Bachelors program. The Student is guaranteed admission to a CSU upon completion of this program. The Transfer Degree is designed to provide students with a Transfer Model Curriculum is to develop a critical understanding of social processes and structures in order to apply the tools of social analysis to a broad range of professional, academic and community situations. The methods and knowledge developed by sociologists reflect the complexity and human organization, social life, inequalities and social justice. The sociology major stresses the ability to observe, organize and write clearly, as well as the development of skills in the analysis of data and collaborations. The Associate of Arts in Sociology for Transfer Degree is designed to prepare students for transfer into the CSU.

The intent of the Associate in Arts in Sociology for Transfer Degree is to assist students in seamlessly transferring to CSU. Senate Bill (SB) 1440 and the California Education Code (CEC) section 66746 require students seeking an Associate in Arts in Sociology for Transfer Degree to:

- (1) Complete 60 semester units of 90-quarter units that are eligible for transfer to the California State University, including both of the following?
  - a. The Intersegmental General Education Transfer curriculum (IGETC) or the California State University General Education-Breadth Requirements
  - b. A minimum of 18 semester units or 27 quarter units in a major or area of emphasis, as determined by the community college district.
- (2) Obtainment of a minimum grade point average of 2.0. ADTs also require that students must earn a C or better in all courses required for the major area of emphasis. A "P" (Pass) grade is not an acceptable grade for courses in the major.

Students should meet with a counselor to determine the necessary course work to complete the general education requirements.

**Program Objectives:**

1. To develop a critical understanding of social processes and structures in order to apply the tools of social analysis to a broad range of professional, academic and community situations.
2. The methods and knowledge developed by sociologists reflect the complexity and human organization, social life, inequalities and social justice.
3. The ability to observe, organize and write clearly, as well as the development of skills in the analysis of data and collaborations.

<b>Required Courses:</b>		<b>Units</b>
SOC 1	Introduction to Sociology .....	3
SOC 2	American Social Problems .....	3
SOC 4	Sociological Analysis .....	3
SOC 12	Marriage and Family Life .....	3
SOC 11	Race and Ethnic Relations .....	3

**Select ONE course:**

SOC 7	Juvenile Delinquency .....	3
SOC 19	Introduction to the Social Services .....	3
SOC 45	Sociology Of Media And Popular Culture: Examining Hip Hop .....	3
MATH 227	Statistics .....	4



TOTAL UNITS .....18-19

**CERTIFICATE OF ACHIEVEMENT**  
**Administration of Justice**

Student Learning Outcome:

Upon completion of this program, students will:

- 1) Analyze and compare the most frequently used investigative techniques, tactics and processes.
- 2) Identify the crime problems, philosophy and history of enforcing laws, and theories of crime and delinquency.
- 3) Evaluate, select and explain which investigative procedure would be the most appropriate to employ for a particular crime and/or scene, as described.
- 4) Write investigative report using the data you are provided from a criminal occurrence.

Required Courses:	Units
ADM JUS 1 Introduction to Administration of Justice	3
ADM JUS 2 Concepts of Criminal Law	3
ADM JUS 3 Legal Aspects of Evidence	3
ADM JUS 4 Principles and Procedures of the Justice System	3
ADM JUS 5 Criminal Investigation	3
ADM JUS 6 Patrol Procedures	3
ADM JUS 14 Report Writing for Peace Officers	3
ADM JUS 67 Community Relations I	3
ADM JUS 310 FIELD WORK I	3
<b>TOTAL UNITS</b>	<b>27</b>

**CERTIFICATE OF ACHIEVEMENT**  
**Chemical Dependency Counselor**

Student Learning Outcome:

Upon completion of this program, students will:

- 1) Discuss, describe, and demonstrate the intake/initial interviewing process in a clinical setting.
- 2) Discuss, describe, and demonstrate the treatment planning process in a clinical setting.

Required Courses:	Units
<b>Semester 1</b>	
PSYCH 1 General Psychology I	3
PSYCH 63 Alcohol/Drug Studies: Prevention and Education	3
PSYCH 64 Introduction to Drug and Alcohol Abuse	3
PSYCH 65 Chemical Dependency: Intervention, Treatment and Recovery	3
<b>Semester 2</b>	
PSYCH 2 Biological Psychology	3
PSYCH 14 Abnormal Psychology	3
OR	
PSYCH 41 Life-Span Psychology: From Infancy to Old Age	3
PSYCH 37 Psychology of Co-Dependency and Family Systems	3
PSYCH 67 Counseling Techniques for the Chemically Addicted	3
<b>Semester 3</b>	
PSYCH 43 Principles of Group Dynamics I	3

plus any class above not completed

<b>Semester 4</b>	
PSYCH 81 Field Work I	3
<b>Semester 5</b>	
PSYCH 82 Field Work II	3
<b>Total Units</b>	<b>33</b>

**SKILL CERTIFICATE**  
**Chemical Dependency Specialist in Criminal Justice**

Student Learning Outcome:

Upon completion of this programs, students will:

1. Discuss, describe, and demonstrate the intake/initial interviewing process in a criminal justice setting.
2. Discuss, describe, and demonstrate the treatment planning process in a criminal justice setting.

Required Courses:	Units
ADM JUS 1 Introduction to Administration of Justice	3
ADM JUS 75 Introduction to Corrections	3
PSYCH 64 Introduction to Alcohol and Drug Abuse	3
PSYCH 65 Chemical Dependency: Intervention, Treatment, and Recovery	3
PSYCH 67 Counseling Techniques for Chemically Addicted	3
<b>TOTAL UNITS</b>	<b>15</b>

**SKILL CERTIFICATE**  
**Fingerprinting**

Student Learning Outcome:

Upon completion of this program, students will:

1. Compare and contrast the differences in various fingerprint characteristics.
2. Analyze and describe different fingerprint patterns and how they affect fingerprint classification.
3. Proficiently acquire several clear and accurate sets of fingerprints; compare and classify them according to their patterns.

Required Courses:	Units
ADM JUS 1 Introduction to Administration of Justice	3
ADM JUS 3 Legal Aspects of Evidence	3
ADM JUS 62 Fingerprint Classification	3
<b>TOTAL UNITS</b>	<b>9</b>

**SKILL CERTIFICATE**  
**Recovery Specialist**

Student Learning Outcome:

Upon completion of this program, students will:

1. Discuss and describe the substance abuse recovery process.
2. Discuss and describe the intake/initial interviewing process in a clinical setting.
3. Discuss and describe the treatment planning process in a clinical setting.

Required Courses:	Units
PSYCH 1 General Psychology I	3
PSYCH 63 Alcohol/Drug Studies: Prevention and Education	3
PSYCH 64 Introduction to Alcohol and Drug Abuse	3



PSYCH 65	Chemical Dependency: Intervention, Treatment, and Recovery .....	3
PSYCH 67	Counseling Techniques for Chemically Addicted .....	3
<b>TOTAL UNITS</b> .....		<b>15</b>

**SKILL CERTIFICATE**

**Social Services**

Student Learning Outcome:

Upon completion of this program, students will:

1. Analyze social problems from major theoretical approaches in historical and socio-cultural context.
2. Identify a community-based approach to solving a social problem.
3. Define the nature and scope of social work, including the nature of the relationship between social worker and client.

<b>Required Courses:</b>		<b>Units</b>
SOC 2	American Social Problems.....	3
SOC 7	Juvenile Delinquency .....	3
SOC12	Marriage and Family Life.....	3
SOC19	Introduction to the Social Services .....	3
SOC 20	Directed Practice in Social Welfare .....	3
<b>TOTAL UNITS</b> .....		<b>15</b>

**SKILL CERTIFICATE**

**Teacher Assistant**

<b>Required Courses:</b>		<b>Units</b>
EDUC 1	Introduction to Teaching.....	3
EDUC 203	Education in American Society .....	3
EDUC 385	Directed Study-Education .....	3
CH DEV 1	Child Growth and Development.....	3
ENGLISH 28	Intermediate Reading and Composition I .....	3
MATH 115	Elementary Algebra.....	5
<b>TOTAL UNITS</b> .....		<b>20</b>





# BUSINESS

School of Career & Technical Education, Room 235  
(323) 241-5415  
www.lasc.edu/business/

James E. Hicks, Department Chair

The Business Department offers students the opportunity to acquire skills in a number of dynamic areas that encompass various business related disciplines for present and upcoming marketable industries. Since all businesses include technology, this is where you will find anything having to do with educating you in:

- Accounting..... Business, economics, finance, marketing, management, supervision
- Real Estate ..... Computer science, Information and computer technology,
- Law/Paralegal ..... Office administration, software applications
- Electronics, engineering

Degree and Certificate programs are designed to prepare students for immediate employment, promotional advancement and transfer opportunities in your field of endeavor.

All students, even those who are just interested in updating their computer skills, may earn certificates of completion in a wide variety of business-related computer application programs.

## Faculty

### Naja El-Khoury (2009)

Instructor, Computer Science and Information Technology  
B.S., National University, San Diego  
M.B.A., National University, Los Angeles, M.S., National University, Los Angeles  
[elkhoury@lasc.edu](mailto:elkhoury@lasc.edu)

### Majid Haghoo (1999)

Professor, Computer Science and Information Technology  
M.S., University of Southern California  
Ph.D., University of Southern California  
[HaghooM@lasc.edu](mailto:HaghooM@lasc.edu)

### James E. Hicks (1998)

Professor, Computer Science and Information Technology  
B.S., Morgan State University  
M.S., University of Wisconsin, M.S., University of California, Los Angeles  
[hicksje@lasc.edu](mailto:hicksje@lasc.edu)

### Carolyn Magee (1989)

Professor, Computer Applications & Office Technology  
B.S., University of Southern Mississippi  
M.A., California State University, Los Angeles  
[MageeCL@lasc.edu](mailto:MageeCL@lasc.edu)

### Niladri R. Mantena (1996)

Professor, Electronics & Computer Technology  
B.S., Andhra University, , B.S.E.E., Madras Institute of Technology  
M.S., Indian Institute of Technology  
Ph.D., University of California, Berkeley  
[MantenN@lasc.edu](mailto:MantenN@lasc.edu)

### Joanne Mrava (1974)

Professor, Business Administration  
A.A., Long Beach City College  
B.S., University of Southern California  
M.S., University of Southern California  
[MravaJA@lasc.edu](mailto:MravaJA@lasc.edu)

### Nouha Toure (2000)

Associate Professor, Business & Economics  
A.A., Los Angeles Southwest College  
B.S., Woodbury University  
M.B.A., National University  
[ToureN@lasc.edu](mailto:ToureN@lasc.edu)

## ADJUNCT PROFESSORS

Andrassy, K.....	Economics
Bowman, J.....	Law, Business, CSIT
Brumfield, M.....	Supervision
Chevchyan, G.....	Supervision
Childress, C.....	CSIT
Cochran, T.....	CSIT
Coney, A.....	N/A
Dennis, D.....	N/A
Duncan, L.....	Law
Elrington, D.....	Economics,
Fletcher, L.....	Business, Law
Foreman Asberry, S.....	CSIT
Gjenaii, G.....	Finance
Glaze, E.....	CAOT
Grigoryan, L.....	N/A
Halley, L.....	N/A
Harrison-Boyer, V.....	Business
Hawkins, R.....	Business
Herrington, S.....	CSIT
Holland, H.....	CSIT
Howard P.....	N/A
Toauk, H.....	CSIT
Pedalino, J.....	Electronics
Manyweather, L.....	Business
Marshall, A.....	CAOT
Maschler K.....	CAOT
McCants-Reed, D.....	Speech, Law
McCaskill, T.....	Business
McIntosh, J.....	N/A
Moore, A.....	Accounting
Morimoto, C.....	CAOT
Nagthall, N.....	N/A
Pedalino, J.....	Electronics
Rose, M.....	Business,
Seymour, C.....	Economics
Simmons, N.....	Business
Srinivasan, R.....	Finance
Ssensalo, N.....	N/A
Taouk, H.....	CSIT
Thomas, K.....	Management
Unutoa, K.....	Accounting, Finance
Valdivia, L.....	CAOT
Valdivia O.....	CAOT
Vanderpool, J.....	Business
Washington, R.....	Business
Wilson, D.....	Business
Yanza, Norma.....	N/A

## STAFF

Morgado, Osmin.....	Instructional Asst. Info. Tech.
Owens, Yvonne.....	Instructional Assistant
Quach, John.....	Instructional Asst. Info. Tech.

## DISCIPLINES

- Accounting
- Business
- Computer Applications and Office Technologies
- Computer Science & Information Technologies
- Computer Technology
- Economics
- Electronics
- Engineering
- Finance
- International Business
- Law/Paralegal
- Management
- Manufacturing and Industrial Technology
- Marketing
- Real Estate
- Supervision

## ASSOCIATE DEGREES

- Business Administration AS-T
- Business Administration: Accounting/General Business
- Business Administration: Banking and Finance
- Business Administration: Economics
- Computer Applications and Office Technology
- Computer Science: Information Technology
- Electronics Technology
- Law-Paralegal
- Liberal Arts: Computer Applications and Office Technology
- Liberal Arts: Computer Science
- Liberal Arts: Electronics
- Liberal Arts: Real Estate
- Management/Supervision



## CERTIFICATES OF ACHIEVEMENTS

- Banking and Finance
- Economics
- General Business
- Homeland Security and Computer Networks
- Homeland Security Network Administrator
- Management/Supervision
- Real Estate: Broker

## SKILL CERTIFICATES

- Bookkeeping
- Business and Technology Skills
- Certified internet Webmaster Associate
- Computer Technician
- Electronics Technician
- Finance
- General Office Assistant
- Income Tax Form
- Law Office Specialist I
- Legal Office Assistant
- Management
- Microsoft Excel
- Microsoft Word
- Network Cabling Technician
- Real Estate: Escrow
- Real Estate: Salesperson
- Receptionist
- Small Business Entrepreneurship I
- Small Business Entrepreneurship II
- Supervision
- Telecom and Network Technician
- Web Site Designer
- Word Processor

### Associate in Arts Degree at LASC

Requirements are:

- Complete a minimum of 21 units of LACCD GENERAL EDUCATION REQUIREMENTS,
- Complete REQUIRED COURSES earning a "C" or better in each course,

- Complete additional units chosen from RECOMMENDED ELECTIVES (where optioned),
- Complete a balance of degree-applicable electives, to total 60 units with a minimum of a 2.0 grade point average.

### Transfer Students

Completing the Associate Degree does not necessarily meet the university admission requirements for transfer. If you would like to transfer to a university, early educational planning can make this goal achievable. For information regarding the requirements to transfer to a University of California (UC), or California State University (CSU) campus, please consult with a counselor.

### ASSOCIATE IN SCIENCE in Business Administration for Transfer

The Associate in Science in Business Administration for Transfer Degree is intended for students who are planning to transfer to a California State University (CSU) institution into the Business Bachelors program. The Student is guaranteed admission to a CSU upon completion of this program. The degree prepares students to continue their formal education in the business field at a four-year CSU. The degree combines the foundation necessary for Business Administration with equal emphasis on university parallel courses in Liberal Arts and STEM.

The Associate in Science in Business Administration for Transfer Degree requirements include: (1) completion of 60 CSU transferable units, including the minimum 29-32 units in the major and the completion of either IGETC or CSU GE; (2) a minimum GPA of 2.0. (3) A grade of "C" or better in all courses required for the major or area of emphasis.

The intent of the Associate in Science in Business Administration for Transfer Degree is to assist students in seamlessly transferring to CSU.

Senate Bill (SB) 1440 and the California Education Code (CEC) section 66746 require students seeking an Associate in Science in Business Administration for Transfer Degree to:

- Complete 60 semester units of 90-quarter units that are eligible for transfer to the California State University, including both of the following?
  - The Intersegmental General Education Transfer curriculum (IGETC) or the California State University General Education-Breadth Requirements
  - A minimum of 18 semester units or 27 quarter units in a major or area of emphasis, as determined by the community college district.
- Obtainment of a minimum grade point average of 2.0. ADTs also require that students must earn a C or better in all courses required for the major area of emphasis. A "P" (Pass) grade is not an acceptable grade for courses in the major. Students should meet with a counselor to determine the necessary course work to complete the general education requirements.

<b>Required Courses:</b>		<b>Units</b>
ACCTG 1	Introductory Accounting I .....	5
ACCTG 2	Introductory Accounting II .....	5
ECON 1	Principles of Economics I .....	3
ECON 2	Principles of Economics II .....	3
BUS 5	Business Law I .....	3
Select One Course		
MATH 227	Statistics .....	4
OR		
MATH 235	Finite Mathematics .....	5
OR		
MATH 265	Calculus with Analytic Geometry I .....	5
Select Two Courses		
CO SCI 660	Business Systems Design .....	3
OR		
CO SCI 601	Introduction to Computers and Their Uses ..	3
BUS 1	Introduction to Business .....	3
TOTAL UNITS .....		29-32

**ASSOCIATE IN ARTS**  
**Business Administration: Accounting/General Business**

Student Learning Outcomes:

Upon completion of this program, students will:

1. Accumulate, record, and analyze financial data.
2. Prepare accurate reports following generally accepted accounting principles and ethical standards of the profession for decision-making and regulatory compliance.
3. Analyze financial reports and communicate the results to both financial and non-financial stakeholders.
4. Apply accounting and business terminology used in business scenarios, and be proficient with commonly used office software systems.
5. Decode, evaluate and analyze the ethics of an accounting scenario and analyze the scenario through effective written communication.

<b>Required Courses:</b>		<b>Units</b>
ACCTG 21	Bookkeeping and Accounting I .....	3
AND		
ACCTG 22	Bookkeeping and Accounting II .....	3
OR		
ACCTG 1	Introductory Accounting I .....	5
ACCTG 2	Introductory Accounting II .....	5
BUS 1	Introduction to Business .....	3
BUS 5	Business Law I .....	3
ECON 1	Principles of Economics I .....	3
ECON 2	Principles of Economics II .....	3
TOTAL UNITS .....		22-23

<b>Recommended Electives</b>		
ACCTG 15	Tax Accounting .....	3
BUS 6	Business Law II .....	3
BUS 38	Business Computations .....	3
CAOT 82	Microcomputer Software Survey in the Office .....	3
CAOT 83	Microcomputer Office Applications: Operating System .....	1
CAOT 85	Microcomputer Office Applications Spreadsheet .....	3
MATH 227	Statistics .....	4
MATH 235	Finite Mathematics .....	5
MATH 236	Calculus for Business and Social Science .....	5

**ASSOCIATE IN ARTS**  
**Business Administration: Banking and Finance**

Student Learning Outcome:

Upon completion of this program, students will:

1. Demonstrate skills needed to work in a supervisory capacity in a bank after some initial training.
2. Examine the broad operations of a bank or financial institution.
3. Use a spreadsheet for banking needs to analyze data for reporting to senior management.
4. Demonstrate skills needed to supervise 3 to 4 people in a bank or financial institution.
5. Examine the legal implication of various financial transactions.

<b>Required Courses:</b>		<b>Units</b>
ACCTG 1	Introductory Accounting I .....	5
ACCTG 2	Introductory Accounting II .....	5
BUS 1	Introduction to Business .....	3
BUS 5	Business Law I .....	3
CAOT 85	Microcomputer Applications .....	3
FIN 1	Principles of Finance .....	3
FIN 15	Principles of Banking .....	3
ECON 1	Principles of Economics I .....	3
ECON 2	Principles of Economics II .....	3
TOTAL UNITS .....		31

**Recommended Electives**

CAOT 1	Computer Keyboarding I .....	3
CAOT 82	Microcomputer Software Survey in the Office .....	3
CAOT 83	Microcomputer Office Applications: Operating Systems .....	1
MATH 235	Finite Mathematics .....	5
MATH 236	Calculus for Business and Social Science .....	5

**ASSOCIATE IN ARTS**  
**Business Administration: Economics**

Student Learning Outcome:

Upon completion of this program, students will:

1. Analyze the role of supply and demand in a free market economy and the necessary elements to function efficiently.
2. Evaluate the advantages of a free market economy and the role of competitive pricing in achieving efficiency.
3. Define, analyze, and demonstrate economic problems using statistical methods, figures, and graphs.

<b>Required Courses:</b>		<b>Units</b>
ACCTG 1	Introductory Accounting I .....	5
ACCTG 2	Introductory Accounting II .....	5
BUS 1	Introduction to Business .....	3
CAOT 85	Microcomputer Office Applications: Spreadsheet .....	3
ECON 1	Principles of Economics I .....	3
ECON 2	Principles of Economics II .....	3
MATH 227	Statistics .....	4
TOTAL UNITS .....		26

**Recommended Electives**

BUS 5	Business Law I .....	3
BUS 6	Business Law II .....	3



CAOT 75	Word Processing: Equipment Operation .....	2
CAOT 82	Microcomputer Software Survey in the Office .....	3
CAOT 83	Microcomputer Office Applications: Operating Systems .....	1
MATH 235	Finite Mathematics .....	5

**ASSOCIATE IN SCIENCE**  
**Computer Applications and Office Technology**

Student Learning Outcome:

Upon completion of this program, students will:

1. Create and demonstrate a PowerPoint presentation as well as a chart to depict data graphically.
2. Write a business letter using standard business format including 7 basic elements and design a newsletter.
3. Compare and contrast web browsers and identify web domains.

<b>Required Courses:</b>		<b>Units</b>
CAOT 3	Computer Keyboarding III .....	3
CAOT 31	Business English .....	3
CAOT 32	Business Communications .....	3
CAOT 33	Records Management and Filing .....	2
CAOT 43	Office Procedures .....	3
CAOT 47	Applied Office Practice .....	2
CAOT 64	Office Administration Laboratory .....	1
CAOT 82	Microcomputer Software Survey in the Office .....	3
CAOT 84	Microcomputer Office Applications: Word Processing .....	3
CAOT 85	Microcomputer Office Applications: Spreadsheet .....	3
CAOT 97	Introduction to the Internet for CAOT .....	3
MGMT 31	Human Relations for Employees .....	3
<b>TOTAL UNITS</b> .....		<b>32</b>

<b>Recommended Electives</b>		
BUS 1	Introduction to Business .....	3
BUS 5	Business Law .....	3
BUS 38	Business Computations .....	3
CAOT 1	Computer Keyboarding I .....	3
CAOT 2	Computer Keyboarding II .....	3
CAOT 34	Business Terminology .....	2
CAOT 83	Microcomputer Office Applications: Operating Systems .....	1
CAOT 86	Microcomputer Office Applications: Data Base .....	3
CAOT 107	Advanced Web Design for the Office .....	3
CAOT 109	Web Multimedia for Office .....	3
CAOT 112	Microcomputer Office Applications: Web Page Design .....	3
CAOT 113	Introduction to Adobe Photoshop for the Office .....	3
CAOT 133	How to Succeed in an Online Course .....	1
CAOT 134	How to Teach an Online Course .....	1.5
MGMT 33	Personnel Management .....	3

**ASSOCIATE IN SCIENCE**  
**Computer Science: Information Technology**

Student Learning Outcome:

Upon completion of this program, students will:

1. Perform computational tasks using operating system environments and develop problem solving algorithms for given tasks.
2. Demonstrate application of computer science concepts, including the study of the properties of algorithms, which includes linguistics, virtual hardware development, and application development.

<b>Required Courses:</b>		<b>Units</b>
CO SCI 601	Introduction to Computers and Their Uses .....	3
CO SCI 602	Introduction to Computer Science .....	3
CO SCI 608	Beginning BASIC Programming .....	3
CO SCI 617	Beginning Micro Assembly Language .....	3
CO SCI 630	Microcomputer Application Software .....	3
CO SCI 632	Introduction to Databases .....	3
CO SCI 636	Introduction to Data Structures .....	3
CO SCI 639	Programming in C .....	3
CO SCI 660	Business Systems Design .....	3
<b>TOTAL UNITS</b> .....		<b>27</b>

**Recommended Electives**

CO SCI 681	Computer Networking I .....	4
CO SCI 682	Computer Networking II .....	4
CO SCI 688	Computer Project .....	2

**ASSOCIATE IN SCIENCE**  
**Electronics Technology**

Student Learning Outcome:

Upon completion of this program, students will:

<b>Required Courses:</b>		<b>Units</b>
ELECTRN 2	Introduction to Electronics .....	3
OR		
ELECTRN 15	Survey of Computer Electronics .....	3
ELECTRN 8	Electron Devices .....	4
ELECTRN 41	Measurement and Testing Laboratory I .....	1
OR		
ELECTRN 43	Measurement and Testing Laboratory I .....	1
ELECTRN 56	Computer Circuits .....	3
ELECTRN 57	Computer Circuits Laboratory .....	1
ELECTRN 111	Introduction to Computer Servicing .....	4
ELECTRN 112	Computer Operating Systems .....	4
ELECTRN 113	Computer Networking .....	4

**PLUS 12 units from the following: Units**

CO SCI 601	Introduction to Computers and Their Uses .....	3
CO SCI 630	Microcomputer Application Software .....	3
MATH 115	Elementary Algebra .....	5
MATH 125	Intermediate Algebra .....	5
MATH 260	Pre-Calculus .....	5
PHYSICS 6	General Physics I .....	4
PHYSICS 7	General Physics II .....	4
<b>TOTAL UNITS</b> .....		<b>36</b>

**ASSOCIATE IN ARTS  
Law-Paralegal**

Student Learning Outcome:

Upon completion of this program, students will:

1. Analyze a legal problem, and determine a strategy to correct the problem.
2. Write a legal brief addressing the broader scope of a legal problem.

Required Courses:		Units
BUS 5	Business Law I .....	3
BUS 6	Business Law II .....	3
LAW 3	Civil Rights and the Law .....	3
LAW 10	Introduction to Legal Assistant I .....	3
LAW 11	Introduction to Legal Assistant II .....	3
LAW 12	Tort Law and Claims Investigation .....	3
LAW 13	Wills, Trusts, and Probate Administration .....	3
LAW 14	Law Office Management .....	3
LAW 15	Property, Bankruptcy, and Family Law .....	3
LAW 16	Civil and Criminal Evidence .....	3
LAW 17	Legal Writing .....	3
CAOT 82	Microcomputer Software Survey in the Office .....	3
<b>TOTAL UNITS</b> .....		<b>36</b>

**Recommended Electives**

ACCTG 1	Introductory Accounting I .....	5
ACCTG 15	Tax Accounting I .....	3
ACCTG 941	Cooperative Education: Accounting .....	4
BUS 38	Business Computations .....	3
CAOT 1	Computer Keyboarding (1D/1E) .....	3
CAOT 31	Business English .....	3
CAOT 34	Business Terminology .....	2
ENGLISH	101College Reading and Composition I .....	3
SPANISH	14 Spanish for Public Service Personnel .....	3

**ASSOCIATE IN ARTS Liberal Arts: Computer Applications and Office Technology**

Student Learning Outcome:

Upon completion of this program, students will:

1. Write a business letter using standard business format including 7 basic elements and design a newsletter.
2. Create and demonstrate a PowerPoint presentation as well as a chart to depict data graphically.

**Core Courses (Choose and complete 18 units):**

CAOT 2	Computer Keyboarding II .....	3
CAOT 31	Business English .....	3
OR		
CAOT 32	Business Communications .....	3
CAOT 43	Office Procedures .....	3
CAOT 82	Microcomputer Software Survey in the Office .....	3
CAOT 84	Microcomputer Office Applications: Word Processing .....	3
CAOT 85	Microcomputer Office Applications: Spreadsheet .....	3

**ASSOCIATE IN ARTS  
Liberal Arts: Computer Science**

Student Learning Outcome:

Upon completion of this program, students will:

1. Become well-versed in various career opportunities in IT industry and be able to pursue an employment in computer-related fields, as well as, enhance their employability.
2. Use Web technologies, mobile devices, and personal computer technologies and apply their acquired technical skills to navigate and establish presence through the use of cyber and social networking.

**Required Courses:**

CO SCI 601	Introduction to Computers and Their Uses ..	3
CO SCI 602	Introduction to Computer Science .....	3
CO SCI 608	Beginning BASIC Programming .....	3
CO SCI 630	Microcomputer Application Software .....	3
CO SCI 632	Introduction to Databases .....	3
CO SCI 636	Introduction to Data Structures .....	3

**ASSOCIATE IN ARTS  
Liberal Arts: Electronics**

Student Learning Outcome:

Upon completion of this program, students will:

1. Discern the main differences between conductors and non-conductors of electric current and quantify them.
2. Draw a simple electronic circuit and label the four main elements.

**Core Courses (Choose and complete 18 units):**

ELECTRN 2	Introduction to Electronics .....	3
ELECTRN 8	Electron Devices .....	4
ELECTRN 41	Measurements and Testing Laboratory I .....	1
OR		
ELECTRN 43	Measurements and Testing Laboratory II .....	1
ELECTRN 56	Computer Circuits .....	3
ELECTRN 57	Computer Circuits Laboratory .....	1
ELECTRN 111	Introduction to Computer Servicing .....	4
ELECTRN 116	Computer A+ and Network+ Certificate Exam Prep .....	2

**ASSOCIATE IN ARTS  
Liberal Arts: Real Estate**

Student Learning Outcome:

Upon completion of this program, students will:

1. Pass DRE salespersons exam;
2. Demonstrate skills necessary to work in a real estate office, including the selling and listing of properties.

**Core Courses (Choose and complete 18 units):**

REAL ES 1	Real Estate Principles .....	3
REAL ES 3	Real Estate Practices .....	3
REAL ES 5	Legal Aspects of Real Estate I .....	3
REAL ES 7	Real Estate Finance I .....	3
REAL ES 9	Real Estate Appraisal I .....	3
REAL ES 10	Real Estate Appraisal II .....	3
REAL ES 14	Property Management .....	3



## ASSOCIATE IN ARTS Management/Supervision

Student Learning Outcome:

Upon completion of this program, students will:

1. Examine planning, organizing, scheduling, and controlling management functions.
2. Demonstrate communication and analytical skills on various management issues.
3. Demonstrate supervisory skills and how they operate in practical situations.

Required Courses:		Units
BUS 1	Introduction to Business .....	3
BUS 5	Business Law I .....	3
CAOT 85	Microcomputer Office Applications: Spreadsheet .....	3
MGMT 2	Organization and Management Theory .....	3
MGMT 13	Small Business Entrepreneurship .....	3
MGMT 31	Human Relations for Employees .....	3
MGMT 33	Personnel Management .....	3
SUPV 1	Elements of Supervision .....	3
TOTAL UNITS .....		24

### Recommended Electives Units

ACCTG 1	Introductory Accounting I .....	5
ACCTG 2	Introductory Accounting II .....	5
BUS 6	Business Law II .....	3
CAOT 1	Computer Keyboarding I .....	3
CAOT 75	Word Processing: Equipment Operation .....	2
CAOT 83	Microcomputer Office Applications: Operation Systems .....	1
ECON 1	Principles of Economics I .....	3
ECON 2	Principles of Economics II .....	3
MATH 235	Finite Mathematics .....	5
PHILOS 1	Introduction to Philosophy .....	3

## CERTIFICATE OF ACHIEVEMENT Banking and Finance

Student Learning Outcome:

Upon completion of this program, students will:

1. Inspect the complex system of Banking and how they are divided according to functions.
2. Examine the relationship between banks, customers, Federal Reserve System, and various regulatory agencies.
3. Analyze the risks involved in lending and how to comply with various regulations while earning a profit for the shareholders/investors.
4. Perform any function in a bank or financial institution and will assess the consequences of their actions.

Required Courses:		Units
ACCTG 1	Introductory Accounting I .....	5
ACCTG 2	Introductory Accounting II .....	5
BUS 1	Introduction to Business .....	3
BUS 5	Business Law I .....	3
CAOT 85	Microcomputer Applications .....	3
FINANCE 1	Principles of Finance .....	3
FINANCE 15	Principles of Banking .....	3
ECON 1	Principles of Economics I .....	3
ECON 2	Principles of Economics II .....	3

TOTAL UNITS ..... 31

## CERTIFICATE OF ACHIEVEMENT General Business

Student Learning Outcome:

Upon completion of this program, students will:

1. Analyze the role of supply and demand in a free market economy and the necessary elements to function efficiently.
2. Evaluate the advantages of a free market economy and the role of competitive pricing in achieving efficiency.
3. Define, analyze, and demonstrate economic problems using statistical methods, figures, and graphs.

Required Courses:		Units
ACCTG 1	Introductory Accounting I .....	5
ACCTG 2	Introductory Accounting II .....	5
BUS 1	Introduction to Business .....	3
BUS 5	Business Law I .....	3
BUS 38	Business Computations .....	3
CAOT 85	Microcomputer Office Applications: Spreadsheet .....	3
ECON 1	Principles of Economics I .....	3
ECON 2	Principles of Economics II .....	3
TOTAL UNITS .....		28

## CERTIFICATE OF ACHIEVEMENT Homeland Security and Computer Networks

Student Learning Outcome:

Upon completion of this program, students will:

1. Understand fundamental networking technologies, including topologies, Open System Interconnection (OSI), network architecture, simple and complex network operations, and protocols and apply knowledge to case studies relevant to real-life situations.
2. Plan for server deployment and installation and configuration. Set up Active Directory and accounts management and prepare for management, monitoring and maintaining the server's security and policies. Secure remote access, wireless, and virtual private networks (VPN) against hackers' attacks.
3. Enumerate the phases of the security systems development life cycle (SecSDLC) and identifying specific threats, and then creating specific controls to counter those threats.

Required Courses		Units
CO SCI 600	Practical PC and Career Technologies .....	1
CO SCI 601	Introduction to Computers and Their Uses ...	3
CO SCI 630	Microcomputer Application Software .....	3
CO SCI 641	Computer Forensics I .....	3
CO SCI 681	Introduction to Networking .....	4
CO SCI 682	Server Administration & Network Security. ....	4
CO SCI 683	Principles of Information Systems Security .....	3
TOTAL UNITS .....		21

**CERTIFICATE OF ACHIEVEMENT  
Homeland Security Network Administrator**

Student Learning Outcome:

Upon completion of this program, students will:

1. Understand fundamental networking technologies, including topologies, Open System Interconnection (OSI), network architecture, simple and complex network operations, and protocols and apply knowledge to case studies relevant to real-life situations. **(CO SCI 681)**
2. Plan for server deployment and installation and configuration. Set up Active Directory and accounts management and prepare for management, monitoring and maintaining the server's security and policies. Secure remote access, wireless, and virtual private networks (VPN) against hackers' attacks. **(CO SCI 682)**

<b>Required Courses:</b>		<b>Units</b>
CO SCI 600	Practical PC and Career Technologies .....	1
CO SCI 601	Introduction to Computers and Their Users ..	3
CO SCI 630	Microcomputer Application Software .....	3
CO SCI 681	Introduction to Computer Networking .....	4
CO SCI 682	Server Administration & Network Security ..	4
<b>TOTAL UNITS</b> .....		<b>15</b>

**CERTIFICATE OF ACHIEVEMENT  
Management/Supervision**

Student Learning Outcome:

Upon completion of this program, students will:

1. Demonstrate communication and analytical skills for business management functions as well as case studies.
2. Apply knowledge of the process, practice and theory of management principles.

<b>Required Courses:</b>		<b>Units</b>
BUS 1	Introduction to Business .....	3
BUS 5	Business Law I .....	3
CAOT 85	Microcomputer Office Applications: Spreadsheet .....	3
MGMT 2	Organization and Management Theory .....	3
MGMT 13	Small Business Entrepreneurship .....	3
MGMT 31	Human Relations for Employees .....	3
MGMT 33	Personnel Management .....	3
SUPV 1	Elements of Supervision .....	3
<b>TOTAL UNITS</b> .....		<b>24</b>

**CERTIFICATE OF ACHIEVEMENT  
Real Estate - Broker**

Student Learning Outcome:

Upon completion of this program, students will:

1. Pass DRE salespersons exam;
2. Demonstrate skills necessary to work in a real estate office, including the selling and listing of properties.

<b>Required Courses:</b>		<b>Units</b>
REAL ES 1	Real Estate Principles .....	3
REAL ES 3	Real Estate Practices .....	3
REAL ES 5	Legal Aspects of Real Estate I .....	3
REAL ES 7	Real Estate Finance I .....	3
REAL ES 9	Real Estate Appraisal I .....	3

REAL ES 11	Escrow Principles .....	3
REAL ES 14	Property Management .....	3
REAL ES 21	Real Estate Economics .....	3
<b>TOTAL UNITS</b> .....		<b>24</b>

**SKILL CERTIFICATE  
Bookkeeping**

Student Learning Outcome:

Upon completion of this program, students will:

1. Enter basic accounting transactions into an accounting software program.
2. Consolidate accounts on a monthly basis to track business income and expenses.
3. Compare and contrast the financial information prepared for different types of business entities.

<b>Required Courses:</b>		<b>Units</b>
ACCTG 1	Introductory Accounting I .....	5
OR		
ACCTG 21	Bookkeeping and Accounting I .....	3
AND		
ACCTG 22	Bookkeeping and Accounting II .....	3
BUS 1	Introduction To Business .....	3
BUS 38	Business Computations .....	3
CAOT 85	Microcomputer Office Applications: Spreadsheet .....	3
COOP ED 295	Work Experience General I .....	2
<b>TOTAL UNITS</b> .....		<b>16-17</b>

**SKILL CERTIFICATE  
Business and Technology Skills**

Student Learning Outcome:

Upon completion of this program, students will:

1. Solve problems and accomplish tasks through MS Excel and Access.
2. Employ MS Office software to create business documents.

<b>Required Courses:</b>		<b>Units</b>
BUS 1	Introduction to Business .....	3
BUS 5	Business Law I .....	3
BUS 38	Business Computations .....	3
CAOT 82	Microcomputer Software Survey in the Office .....	3
CAOT 85	Microcomputer Office Applications: Spreadsheet .....	3
COOP ED 295	Work Experience General I .....	2
<b>TOTAL UNITS</b> .....		<b>17</b>

**SKILL CERTIFICATE  
Certified Internet Webmaster Associate (CIWA)**

Student Learning Outcome:

Upon completion of this program, students will:

1. Produce real-world internet applications
2. Use common internet-ready applications.
3. Create properly formed HTML/XHTML documents.
4. Analyze CGI and database essentials, and troubleshoot networks.





<b>Required Courses:</b>		<b>Units</b>
CO SCI 621	CIWA: Internet Fundamentals .....	3
CO SCI 622	CIWA: Web Page Authoring Fundamentals .....	3
CO SCI 623	CIWA: Networking Fundamentals .....	3
<b>TOTAL UNITS</b> .....		<b>9</b>

**SKILL CERTIFICATE  
Computer Technician**

Student Learning Outcome:

Upon completion of this program, will:

1. Identify the main parts of a computer.
2. Show all steps to create a small network.

<b>Required Courses:</b>		<b>Units</b>
ELECTRN 56	Computer Circuits .....	3
ELECTRN 57	Computer Circuits Laboratory .....	1
ELECTRN 111	Introduction to Computer Servicing .....	4
ELECTRN 112	Computer Operating Systems .....	4
ELECTRN 113	Computer Networking .....	4
<b>TOTAL UNITS</b> .....		<b>16</b>

**SKILL CERTIFICATE  
Economics**

Student Learning Outcome:

Upon completion of this program, students will:

1. Apply business terminology used in business scenarios, and be proficient with commonly used office software systems.
2. Analyze various economic activities in the context of national and global ramifications.

<b>Required Courses:</b>		<b>Units</b>
ACCTG 1	Introductory Accounting I .....	5
ACCTG 2	Introductory Accounting II .....	5
BUS 1	Introduction to Business .....	3
CAOT 85	Microcomputer Office Applications Spreadsheet .....	3
ECON 1	Principles of Economics I .....	3
ECON 2	Principles of Economics II .....	3
MATH 227	Statistics .....	4
<b>TOTAL UNITS</b> .....		<b>26</b>

**SKILL CERTIFICATE  
Electronics Technician**

Student Learning Outcome:

Upon completion of this program, students will:

1. Draw and identify all parts of an electronic circuit.
2. Identify and label the basic eight logic gates.
3. Identify all major subsystems of a computer.

<b>Required Courses:</b>		<b>Units</b>
ELECTRN 2	Introduction to Electronics .....	3
OR		
ELECTRN 8	Electron Devices .....	4
ELECTRN 15	Survey of Computer Electronics .....	3
ELECTRN 41	Measurement and Testing Laboratory I .....	1
OR		
ELECTRN 43	Measurement and Testing Laboratory II .....	1
ELECTRN 56	Computer Circuits .....	3

ELECTRN 57	Computer Circuits Laboratory .....	1
ELECTRN 111	Introduction to Computer Servicing .....	4
<b>TOTAL UNITS</b> .....		<b>16</b>

**SKILL CERTIFICATE  
Finance**

Student Learning Outcome:

Upon completion of this program, students will:

1. Inspect the complex system of Banking and other financial institutions.
2. Examine the relationship between banks, customers, Federal Reserve System, and various regulatory agencies.

<b>Required Courses:</b>		<b>Units</b>
ACCTG 1	Introductory Accounting I .....	5
OR		
ACCTG 21	Bookkeeping and Accounting I .....	3
AND		
ACCTG 22	Bookkeeping and Accounting II .....	3
CAOT 85	Microcomputer Office Applications: Spreadsheet .....	3
COOP ED	Cooperative Work Experience Education .....	2
FINANCE 1	Principles of Finance .....	3
FINANCE 15	Principles of Banking .....	3
<b>TOTAL UNITS</b> .....		<b>16-17</b>

**SKILL CERTIFICATE  
General Office Assistant**

Student Learning Outcome:

Upon completion of this program, students will:

1. Type a minimum of 40 words per minute.
2. Write a business letter using standard business format including 7 elements.
3. Create and demonstrate a PowerPoint presentation.

<b>Required Courses:</b>		<b>Units</b>
CAOT 2	Computer Keyboarding II .....	3
CAOT 31	Business English .....	3
CAOT 33	Records Management & Filing .....	2
CAOT 43	Office Procedures .....	3
CAOT 47	Applied Office Practice .....	2
CAOT 82	Microcomputer Software Survey in the Office .....	3
<b>TOTAL UNITS</b> .....		<b>16</b>

**SKILL CERTIFICATE  
Income Tax Form**

Student Learning Outcome:

Upon completion of this program, students will:

- 1) Prepare and assemble federal and California individual income tax returns.
- 2) Research federal and state tax issues.
- 3) Advise and assist individual clients with federal and state income tax returns and tax planning.

<b>Required Courses:</b>		<b>Units</b>
ACCTG 1	Introductory Accounting I .....	5
ACCTG 15	Tax Accounting I .....	3

BUS 1	Introduction to Business .....	3
BUS 38	Business Computations .....	3
CAOT 85	Microcomputer Office Applications: Spreadsheet .....	3
<b>TOTAL UNITS .....</b>		<b>17</b>

**SKILL CERTIFICATE**  
**Law Office Specialist I**

Student Learning Outcome:

Upon completion of this program, students will:

1. Evaluate the composition, location, and jurisdiction of courts.
2. Prepare and administer legal documents within the judicial structure.
3. Inspect the legal writing process, the goal and the stages of the writing process.
4. Prepare research assignment on legal arguments to present during class discussions.
5. Identify and write major components of a legal brief and Memorandum.

<b>Required Courses:</b>		<b>Units</b>
BUS 5	Business Law I .....	3
BUS 6	Business Law II .....	3
CAOT 1	Computer Keyboarding I. ....	3
LAW 10	Introduction to Legal Assistant .....	3
LAW 17	Legal Writing .....	3
<b>TOTAL UNITS .....</b>		<b>15</b>

**SKILL CERTIFICATE**  
**Legal Office Assistant**

Student Learning Outcome:

Upon completion of this program, students will:

1. Create and demonstrate PowerPoint presentation.
2. Write a business letter using standard business format including 7 elements.
3. Evaluate the elements of the role of a legal decision and the legal assistant.

<b>Required Courses:</b>		<b>Units</b>
LAW 10	Introduction to Legal Assistant .....	3
LAW 14	Law Office Management .....	3
CAOT 2	Keyboarding II .....	3
CAOT 31	Business English .....	3
CAOT 33	Records Management and Filing .....	2
CAOT 82	Microcomputer Software Survey in the Office .....	3
<b>TOTAL UNITS .....</b>		<b>17</b>

**SKILL CERTIFICATE**  
**Management**

Student Learning Outcome:

Upon completion of this program, students will:

1. Apply the process, practice, and theory of management concepts.
2. Interpret, analyze, and communicate management issues with measureable data.

<b>Required Courses:</b>	<b>Units</b>
--------------------------	--------------

CAOT 82	Microcomputer Software Survey in the Office .....	3
MGMT 2	Organization and Management Theory .....	3
MGMT 13	Small Business Entrepreneurship .....	3
MGMT 31	Human Relations For Employees .....	3
MGMT 33	Personnel Management .....	3
<b>TOTAL UNITS .....</b>		<b>15</b>

**SKILL CERTIFICATE**  
**Microsoft Excel**

Student Learning Outcome:

Upon completion of this program, students will:

1. Create and demonstrate PowerPoint presentation.
2. Write a business letter using standard business format including 7 elements.
3. Evaluate the elements of the role of a legal decision and the legal assistant.

<b>Required Courses:</b>		<b>Units</b>
CAOT 2	Computer Keyboarding II .....	3
CAOT 31	Business English .....	3
CAOT 33	Records Management and Filing .....	2
CAOT 85	Microcomputer Office Applications: Spreadsheet .....	3
COOP ED 295	Work Experience General I.....	2
<b>TOTAL UNITS .....</b>		<b>13</b>

**SKILL CERTIFICATE**  
**Microsoft Word**

Student Learning Outcome:

Upon completion of this program, students will:

1. Type a minimum of 40 words per minute.
2. Design a newsletter.

<b>Required Courses:</b>		<b>Units</b>
CAOT 2	Computer Keyboarding II .....	3
CAOT 31	Business English .....	3
CAOT 32	Business Communications .....	3
CAOT 83	Microcomputer Office Applications: Disk Operating Systems .....	1
CAOT 84	Microcomputer Office Applications: Word Processing .....	3
<b>TOTAL UNITS .....</b>		<b>13</b>

**SKILL CERTIFICATE**  
**Network Cabling Technician**

Student Learning Outcome:

Upon completion of this program, students will:

1. Draw the essential parts of a computer network, identify each part, and label it.
2. Verbalize the differences between copper cabling and fiber-optic cabling used to create a computer network

<b>Required Courses:</b>		<b>Units</b>
ELECTRN 2	Introduction to Electronics .....	3
OR		
ELECTRN 15	Survey of Computer Electronics .....	3



ELECTRN 41	Measurement and Testing Laboratory I	..... 3
ELECTRN 112	Computer Operating Systems	..... 4
ELECTRN 113	Computer Networking	..... 4
<b>TOTAL UNITS</b>		<b>..... 14</b>

**SKILL CERTIFICATE**  
**Real Estate – Escrow**

Student Learning Outcome:  
Upon completion of this program, students will:

1. Demonstrate skills necessary to work in an escrow office and take escrows.
2. Prepare buyer and seller closing costs and final statements.

<b>Required Courses:</b>		<b>Units</b>
REAL ES 11	Escrow Principles	..... 3
REAL ES 12	Escrow Practices	..... 3
REAL ES 13	Escrow Case Problems	..... 3
<b>TOTAL UNITS</b>		<b>..... 9</b>

**SKILL CERTIFICATE**  
**Real Estate – Salesperson**

Student Learning Outcome:  
Upon completion of this program, students will:

1. Pass DRE exam, begin to list, sell and rent properties.
2. Explain a closing statement to buyers and sellers.

<b>Required Courses:</b>		<b>Units</b>
REAL ES 1	Real Estate Principles	..... 3
REAL ES 3	Real Estate Practices	..... 3
REAL ES 5	Legal Aspects of Real Estate I	..... 3
<b>TOTAL UNITS</b>		<b>..... 9</b>

**SKILL CERTIFICATE**  
**Receptionist**

Student Learning Outcome:  
Upon completion of this program, students will:

1. Type a minimum of 40 words per minute.
2. Write a business letter using standard business format including 7 elements and create and demonstrate a PowerPoint presentation.

<b>Required Courses:</b>		<b>Units</b>
CAOT 1	Computer Keyboarding 1	..... 3
CAOT 2	Computer Keyboarding II	..... 3
CAOT 31	Business English	..... 3
CAOT 43	Office Procedures	..... 3
CAOT 47	Applied Office Practices	..... 2
CAOT 82	Microcomputer Software Survey in the Office	..... 3
<b>TOTAL UNITS</b>		<b>..... 17</b>

**SKILL CERTIFICATE**  
**Small Business Entrepreneurship Level I**

Student Learning Outcome:  
Upon completion of this program, students will:

1. Evaluate, and utilize the principles of entrepreneurship.
2. Apply and communicate one's own entrepreneurial qualities and characteristics.

<b>Required Courses:</b>		<b>Units</b>
BUS 1	Introduction to Business	..... 3
BUS 5	Business Law I	..... 3
BUS 38	Business Computations	..... 3
CAOT 82	Microcomputer Software Survey in the Office	..... 3
COOP ED 295	Work Experience General I	..... 2
MGMT 13	Small Business Entrepreneurship	..... 3
<b>TOTAL UNITS</b>		<b>..... 17</b>

**SKILL CERTIFICATE**  
**Small Business Entrepreneurship Level II**

Student Learning Outcome:  
Upon completion of this program, students will:

1. Evaluate and utilize the principles of entrepreneurship.
2. Apply and communicate one's own entrepreneurial qualities and characteristics.

<b>Required Courses:</b>		<b>Units</b>
SUPV 1	Elements of Supervision	..... 3
ACCTG 1	Introductory Accounting I	..... 5
CAOT 85	Microcomputer Office Applications: Spreadsheet	..... 3
MARKET 1	Principles of Selling	..... 3
<b>TOTAL UNITS</b>		<b>..... 14</b>

**SKILL CERTIFICATE**  
**Supervision**

Student Learning Outcome:  
Upon completion of this program, students will:

1. Apply management planning, organizing, scheduling, and controlling skills supervisory functions.
2. Demonstrate effective management skills to prepare for a variety of entry-level supervisory positions.

<b>Required Courses:</b>		<b>Units</b>
CAOT 82	Microcomputer Software Survey in the Office	..... 3
COOP ED 295	Work Experience General I	..... 2
SUPV 1	Elements of Supervision	..... 3
MGMT 2	Organization and Management Theory	..... 3
MGMT 33	Personnel Management	..... 3
<b>TOTAL UNITS</b>		<b>..... 14</b>

**SKILL CERTIFICATE**  
**Telecom and Network Technician**

Student Learning Outcome:  
Upon completion of this program, students will:

1. Identify the eight logic gates.



- Identify a network card and install inside the computer.

Required Courses:	Units
ELECTRN 2 Introduction to Electronics .....	3
OR	
ELECTRN 15 Survey of Computer Electronics .....	3
ELECTRN 56 Computer Circuits .....	3
ELECTRN 57 Computer Circuits Laboratory .....	1
ELECTRN 111 Introduction to Computer Servicing .....	4
ELECTRN 113 Computer Networking .....	4
ELECTRN 116 Computer A+ and Network + Exam Preparation .....	2
<b>TOTAL UNITS</b> .....	<b>17</b>

### SKILL CERTIFICATE WEB Site Designer

Student Learning Outcome:

Upon completion of this program, students will:

- Demonstrate a webpage using Dreamweaver and properly edit a flash file based on various parameters.
- Build a website including graphics, sound, video, links, plug-in applications and analyze and edit a digital image.

Required Courses:	Units
CAOT 97 Introduction to the Internet for CAOT .....	3
CAOT 107 Microcomputer Office Applications: Advanced Web Design for the Office .....	3
CAOT 109 Web Multimedia for the Office .....	3
CAOT 112 Microcomputer Office Applications: Web Page Design .....	3
CAOT 113 Introduction to Adobe Photoshop for the Office .....	3
CAOT 285 Independent Study .....	2
<b>TOTAL UNITS</b> .....	<b>17</b>

### SKILL CERTIFICATE Word Processing

Student Learning Outcome:

Upon completion of this program, students will:

- Typing at a minimum of 40 words per minute, write a business letter using standard business format including 7 elements.
- Create a newsletter and develop/demonstrate a PowerPoint presentation.

Required Courses:	Units
CAOT 2 Computer Keyboarding II .....	3
CAOT 31 Business English .....	3
CAOT 43 Office Procedures .....	3
CAOT 47 Applied Office practice .....	2
CAOT 82 Microcomputer Software Survey in the Office .....	3
CAOT 84 Microcomputer Office Applications: Word Processing .....	3
<b>TOTAL UNITS</b> .....	<b>17</b>



# CHILD DEVELOPMENT

Child Development Center Building, Room 210  
 (323) 241-5030  
[www.lasc.edu/chdev/](http://www.lasc.edu/chdev/)

LaShawn Brinson, Department Chair

The Child Development Program prepares individuals for various levels of employment in child development centers, preschools, recreation centers, public school settings, Head Start programs, family and in-home daycare and other areas where caring for young children is the principle function. The program integrates theoretical and empirical concepts of development with field and laboratory experiences. Goals of the Child Development Program are to provide students with an awareness, appreciation and inclusive understanding of variables influencing the development of children.

## The Child Development Program offers each student opportunities to:

- Acquire necessary units for the Child Development Associate in Arts degree, Early Childhood Education AS-T, Liberal Arts: Child Development degree and Child Development Permits
- Participate in a Student Teacher Training program at the LASC Child Development Center Laboratory School and local Child Development Centers
- Receive assistance from quality improvement programs such as The California Early Childhood Mentor Program (CECMP) and The Child Development Training Consortium (CDTC)
- Receive grants, stipends, and participate in professional workshops, trainings, and conferences.

In addition, the faculty and staff provide a very positive learning environment to enhance and ensure student's success. They take pride in offering a comprehensive Child Development Program. The field of early childhood education need well trained passionate and creative educators to provide high quality and respectful services to diverse children and families in a variety of settings. At LASC, students receive the education, training, and support services needed to be successful early childhood educators.

Below are some webpages that will help you pursue your goals in the Child Development field:

[www.childdevelopment.org](http://www.childdevelopment.org)

(Child Development Training Consortium)

<http://www.cde.ca.gov/sp/cd/re/psframework.asp>

(California Curriculum Framework)

[www.ctc.ca.gov](http://www.ctc.ca.gov)

[www.naeyc.org](http://www.naeyc.org)

<http://www.cde.ca.gov/sp/cd/re/psframework.asp> (California Curriculum Framework)

## Faculty

Gail Amos (2016)

Assistant Professor, Child Development  
 B.A., Christian Leadership University, B.A., Pacific Oaks College  
 M.A., Pacific Oaks College  
 Ed.D., Walden University  
[amosge@lasc.edu](mailto:amosge@lasc.edu)

LaShawn Brinson (2002)

Professor, Child Development  
 B.A., California State University, Northridge  
 M.A., Pacific Oaks College  
[brinsonLL@lasc.edu](mailto:brinsonLL@lasc.edu)

Claudia E. Garcia-Oliva (2015)

Assistant Professor, Child Development  
 A.A. Child Development Los Angeles City College  
 B.A., California State University, Los Angeles  
 M.A., California State University, Los Angeles  
[garciace@lasc.edu](mailto:garciace@lasc.edu)

Monica M. Juarez (2013)

Assistant Professor, Child Development  
 B.A., University of Redlands  
 M.A., Pacific Oaks College  
[herradmi@lasc.edu](mailto:herradmi@lasc.edu)

Dawn Robinson (2015)

Assistant Professor, Child Development  
 B.A., Sonoma State University  
 M.A., Mills College  
[robinsdl@lasc.edu](mailto:robinsdl@lasc.edu)

## ADJUNCT PROFESSORS

Aguet, D .....	Child Development
Cliff, K.....	Child Development
Dixon, G .....	Child Development
Fields, S .....	Child Development
Gomez, E .....	Child Development
Monroe, R.....	Child Development
Shaw, T .....	Child Development
Williams, R .....	Child Development

## DISCIPLINES

- Child Development
- Family & Consumer Studies

## ASSOCIATE DEGREES

- Child Development
- Liberal Arts: Child Development
- Early Childhood Education AS-T

## SKILL CERTIFICATES

- Associate Teacher
- Infant and Toddler Studies
- School Age Programs
- Special Needs

### Associate in Arts Degree at LASC

Requirements are:

- Complete a minimum of 21 units of LACCD GENERAL EDUCATION REQUIREMENTS,
- Complete REQUIRED COURSES earning a “C” or better in each course,
- Complete additional units chosen from SPECIALIZED ELECTIVES (where optioned),
- Complete a balance of degree-applicable electives, to total 60 units with a minimum of a 2.0 grade point average.

To receive an Associate of Arts degree in Child Development from LA Southwest College, students must take a minimum of 9 units of Child Development coursework at this institution. Among those units, students are required to complete Child Development 8 - Curriculum in Early Childhood Education (3 units) and Child Development 22 – Practicum in Child Development I (4 units). Students have the right to appeal and may have coursework taken at other institutions evaluated by the Child Development Department.

#### Transfer Students

Completing the Associate Degree does not necessarily meet the university admission requirements for transfer. If you would like to transfer to a university, early educational planning can make this goal achievable. For information regarding the requirements to transfer to a University of

California (UC), or California State University (CSU) campus, please consult with a counselor.

The mission of the Child Development program and Associate in Science in Early Childhood Education for Transfer is to provide an environment for quality learning for a diverse population of students in the discipline of Child Development. Our courses, programs, and activities are designed to educate, inform, and model “Best Practices” for educating and nurturing young children, working with families, and providing services to the community in a variety of early childhood educational careers. The program is designed to meet the educational and vocational training needs of those who are preparing for employment or who are presently employed in public (Title 5) or private (Title 22) preschools. The Child Development Department and Child Development Center laboratory school collectively provide the education and vocational training necessary for LASC Child Development students to succeed in their higher educational/transfer goals, individual career choices, and professional business plans.

### ASSOCIATE IN ARTS Child Development

Program Learning Outcome:

Upon completion of this program, students should be able to:

- Integrate understanding of the needs, the characteristics and multiple influences on the development of children from birth to age eight as it relates to optimum growth and development.
- Create developmentally appropriate strategies, techniques, and curriculum incorporating domains of learning, health, safety, nutrition, as well as anti-bias and adaptation principles for working with typical and atypical developing children.
- Apply developmentally appropriate social emotional learning strategies and positive guidance techniques in a professional early childhood setting.
- Evaluate and utilize various observation and assessment methods for measuring and recording children’s developmental progress.
- Implement various early childhood environmental rating scales and assessment tools.
- Compare and contrast the basic theories in child development, family studies, as well as historical perspectives of ECE programs.
- Uphold professional standards (based on NAEYC Code of Ethics) for job seeking, respecting, interacting, and communicating with others (parents, staff, children, community members, colleagues and peers).
- Demonstrate strategies and techniques for building sensitive and respectful family and community relationships.
- Develop critical thinking and problem solving skills for learning and promoting learning in young children.

#### Required Courses:

	<b>Units</b>
CH DEV 1 Child Growth and Development .....	3
CH DEV 2 Early Childhood: Principles and Practices .....	3
CH DEV 7 Introduction to Early Childhood Curriculum .....	3
CH DEV 8 Curriculum in Early Childhood Education .....	3
CH DEV 10 Health, Safety and Nutrition .....	3
CH DEV 11 Child, Family and Community .....	3
CH DEV 22 Practicum in Child Development I .....	4
CH DEV 23 Practicum in Child Development II .....	4
CH DEV 34 Observing and Recording Children’s Behavior	



CH DEV 42 Teaching in a Diverse Society ..... 3  
**TOTAL UNITS ..... 32**

**Specialized Electives:**

Infant and Toddler Studies  
 CH DEV 30 Infant and Toddler Studies I ..... 3  
 CH DEV 31 Infant and Toddler Studies II ..... 3

Language and Literacy

CH DEV 35 Fostering Literacy Development  
 In Young Children ..... 3  
 CH DEV 36 Literature for Early Childhood ..... 1  
 CH DEV 37 Literature for School Age Children ..... 2

Administrative and Supervision of Early Childhood Programs

CH DEV 38 Administration and Supervision of  
 Early Childhood Programs I ..... 3  
 CH DEV 39 Administration and Supervision of  
 Early Childhood Programs II ..... 3  
 CH DEV 65 Adult Supervision/Early Childhood Mentoring  
 ..... 2

Children with Special Needs

CH DEV 44 Early Intervention for Children with  
 Special Needs I ..... 3  
 CH DEV 45 Programs for Children with  
 Special Needs I ..... 3

School-Age Children and Programs

CH DEV 46 School Age Programs I ..... 3  
 CH DEV 47 School Age Programs II ..... 3

Positive Guidance and Family School Relationships

CH DEV 48 Positive Guidance in Early Childhood  
 Settings ..... 3  
 CH DEV 12 Parent-Teacher-Child Interaction ..... 3

Additional Electives

CH DEV 9 Advanced Curriculum: Art in Early Childhood  
 ..... 3  
 FAM & CS 21 Nutrition ..... 3

**ASSOCIATE in ARTS**  
**LIBERAL ARTS: Child Development**

Program Learning Outcome:

Upon completion of this program, students should be able to:

1. Integrate understanding of the needs, the characteristics and multiple influences on the development of children from birth to age eight as it relates to optimum growth and development.
2. Create developmentally appropriate strategies, techniques, and curriculum incorporating domains of learning, health, safety, nutrition, as well as anti-bias and adaptation principles for working with typical and atypical developing children.
3. Evaluate and utilize various observation and assessment methods for measuring and recording children’s developmental progress.
4. Compare and contrast the basic theories in child development, family studies, as well as historical perspectives of ECE programs.
5. Demonstrate strategies and techniques for building sensitive and Core Courses: (Complete 18 units)

6. Develop critical thinking and problem solving skills for learning and promoting learning in young children.

**Core Courses: (Choose and complete 18 units)**

CH DEV 1 Child Growth and Development ..... 3  
 CH DEV 2 Early Childhood: Principles and  
 Practices ..... 3  
 CH DEV 7 Introduction to Early Childhood Curriculum . 3  
 CH DEV 10 Child Health ..... 3  
 CH DEV 11 Home, School, and Community Relations .... 3  
 CH DEV 42 The Child in a Diverse Society ..... 3

**ASSOCIATE in SCIENCE**  
**in Early Childhood Education for Transfer**

Program Learning Outcomes:

Upon completion of this program, students should be able to:

1. Integrate understanding of the needs, the characteristics and multiple influences on the development of children from birth to age eight as it relates to optimum growth and development.
2. Create developmentally appropriate strategies, techniques, and curriculum incorporating domains of learning, health, safety, nutrition, as well as anti-bias and adaptation principles for working with typical and atypical developing children.
3. Apply developmentally appropriate social emotional learning strategies and positive guidance techniques in a professional early childhood setting.
4. Evaluate and utilize various observation and assessment methods for measuring and recording children’s developmental progress.
5. Implement various early childhood environmental rating scales and assessment tools.
6. Compare and contrast the basic theories in child development, family studies, as well as historical perspectives of ECE programs.
7. Uphold professional standards (based on NAEYC Code of Ethics) for job seeking, respecting, interacting, and communicating with others (parents, staff, children, community members, colleagues and peers).
8. Demonstrate strategies and techniques for building sensitive and respectful family and community relationships.
9. Develop critical thinking and problem solving skills for learning

**Required Courses:**

	<b>Units</b>
CH DEV 1 Child Growth and Development ..... 3	3
CH DEV 2 Early Childhood: Principles and Practices ..... 3	3
CH DEV 7 Introduction to Curriculum in Early Childhood Education ..... 3	3
CH DEV 10 Health, Safety, and Nutrition..... 3	3
CH DEV 11 Child, Family, and Community..... 3	3
CH DEV 22 Practicum in Early Child Development I ..... 4	4
CH DEV 34 Observing and Recording Children’s Behavior ..... 3	3
CH DEV 42 Teaching in a Diverse Society ..... 3	3
<b>TOTAL UNITS ..... 25</b>	<b>25</b>

**SKILL CERTIFICATE**  
**Associate Teacher**

Program Learning Outcome:

Upon completion of this program, students should be able to:

1. Integrate understanding of the needs, the characteristics and multiple influences on the development of children from birth to age eight as it relates to optimum growth and development.
2. Create developmentally appropriate strategies, techniques, and curriculum incorporating domains of learning, health, safety, nutrition, as well as anti-bias and adaptation principles for working with typical and atypical developing children.
3. Implement various early childhood environmental rating scales and assessment tools.
4. Compare and contrast the basic theories in child development, family studies, as well as historical perspectives of ECE programs.
5. Uphold professional standards (based on NAEYC Code of Ethics) for job seeking, respecting, interacting, and communicating with others (parents, staff, children, community members, colleagues and peers).
6. Demonstrate strategies and techniques for building sensitive and respectful family and community relationships.
7. Develop critical thinking and problem solving skills for learning and promoting learning in young children.

<b>Required Courses:</b>		<b>Units</b>
CH DEV 1	Child Growth and Development .....	3
CH DEV 2	Early Childhood: Principles and Practices .....	3
CH DEV 7	Introduction to Early Childhood Curriculum .....	3
OR		
CH DEV 8	Curriculum in Early Childhood Education .....	3
CH DEV 11	Child, Family and Community .....	3
<b>TOTAL UNITS</b> .....		<b>12</b>

**SKILL CERTIFICATE**  
**Infant and Toddler Studies**

Program Learning Outcome:

Upon completion of this program, students should be able to:

1. Integrate understanding of the needs, the characteristics and multiple influences on the development of children from birth to age eight as it relates to optimum growth and development.
2. Create developmentally appropriate strategies, techniques, and curriculum incorporating domains of learning, health, safety, nutrition, as well as anti-bias and adaptation principles for working with typical and atypical developing children.
3. Implement various early childhood environmental rating scales and assessment tools.
4. Compare and contrast the basic theories in child development, family studies, as well as historical perspectives of ECE programs.
5. Demonstrate strategies and techniques for building sensitive and respectful family and community relationships.

6. Develop critical thinking and problem solving skills for learning and promoting learning in young children.

<b>Required Courses:</b>		<b>Units</b>
CH DEV 1	Child Growth and Development .....	3
CH DEV 11	Child, Family and Community .....	3
CH DEV 30	Infant and Toddler Studies I .....	3
CH DEV 31	Infant and Toddler Studies II .....	3
CH DEV 34	Observing and Recording Children's Behavior .....	3
<b>TOTAL UNITS</b> .....		<b>15</b>

**SKILL CERTIFICATE**  
**School Age Programs**

Program Learning Outcome:

Upon completion of this program, students should be able to:

1. Integrate understanding of the needs, the characteristics and multiple influences on the development of children from birth to age eight as it relates to optimum growth and development.
2. Create developmentally appropriate strategies, techniques, and curriculum incorporating domains of learning, health, safety, nutrition, as well as anti-bias and adaptation principles for working with typical and atypical developing children.
3. Apply developmentally appropriate social emotional learning strategies and positive guidance techniques in a professional early childhood setting.
4. Evaluate and utilize various observation and assessment methods for measuring and recording children's developmental progress.
5. Implement various early childhood environmental rating scales and assessment tools.
6. Uphold professional standards (based on NAEYC Code of Ethics) for job seeking, respecting, interacting, and communicating with others (parents, staff, children, community members, colleagues and peers).
7. Demonstrate strategies and techniques for building sensitive and respectful family and community relationships.
8. Develop critical thinking and problem solving skills for learning and promoting learning in young children.

<b>Required Courses:</b>		<b>Units</b>
CH DEV 1	Child Growth and Development .....	3
CH DEV 11	Child, Family and Community .....	3
CH DEV 46	School Age Programs I .....	3
CH DEV 47	School Age Programs II .....	3
CH DEV 48	Positive Guidance in Early Childhood Settings .....	3
<b>TOTAL UNITS</b> .....		<b>15</b>

**SKILL CERTIFICATE**  
**Special Needs**

Program Learning Outcome:

Upon completion of this program, students should be able to:

1. Integrate understanding of the needs, the characteristics and multiple influences on the development of children from birth to age eight as it relates to optimum growth and development.
2. Create developmentally appropriate strategies, techniques,





- and curriculum incorporating domains of learning, health, safety, nutrition, as well as anti-bias and adaptation principles for working with typical and atypical developing children.
- 3. Apply developmentally appropriate social emotional learning strategies and positive guidance techniques in a professional early childhood setting.
- 4. Evaluate and utilize various observation and assessment methods for measuring and recording children’s developmental progress.
- 5. Compare and contrast the basic theories in child development, family studies, as well as historical perspectives of ECE programs.
- 6. Uphold professional standards (based on NAEYC Code of Ethics) for job seeking, respecting, interacting, and communicating with others (parents, staff, children,

- community members, colleagues and peers).
- 7. Demonstrate strategies and techniques for building sensitive and respectful family and community relationships.
- 8. Develop critical thinking and problem solving skills for learning and promoting learning in young children.

<b>Required Courses:</b>		<b>Units</b>
CH DEV 1	Child Growth and Development .....	3
CH DEV 11	Child, Family and Community .....	3
CH DEV 42	Teaching in a Diverse Society .....	3
CH DEV 44	Early Intervention for Children with Special Needs .....	3
CH DEV 45	Programs for Children with Special Needs .....	3
<b>TOTAL UNITS</b> .....		<b>15</b>

## CHILD DEVELOPMENT CENTER

Child Development Center Complex  
323-241-5000  
[www.lasc.edu/chdev/index.html](http://www.lasc.edu/chdev/index.html)

Monica Garcia, Director

The Child Development Center is part of the Child Development Program and serves as a laboratory school for students majoring in Child Development or related disciplines at Los Angeles Southwest College. Child Development students are placed in the center to observe the application of developmentally appropriate practices in early childhood education, to gain “hands-on” knowledge of the implementation of daily lesson plans throughout the curriculum, and to acquire field experience (student teaching) in a quality child development setting for toddlers, preschool and school-age children. In addition, students majoring in Child Development and trying to meet requirements for the Child Development Permit career ladder matrix may apply for employment/training opportunities at the Center.

The Center is licensed to serve children 18 months to 5 years of age in the day program from 7:30 a.m. to 3:00 p.m., Monday through Thursday, and 7:30 a.m. to noon on Fridays. When offered, the evening program accommodates children 3 years (potty trained) to 12 years of age from 6:00 p.m. to 10:00 p.m., Monday through Thursday. The Child Development Center accepts applications year round.



## Faculty

Kaaran Abdullah (1997)  
Professor, Child Development Center  
B.S., California State University, Northridge  
[AbdullKV@lasc.edu](mailto:AbdullKV@lasc.edu)

Debra R. Auria (2000)  
Associate Professor, Child Development Center  
A.A., Los Angeles Harbor College  
B.A., California State University, Dominguez Hills  
[AuriaDR@lasc.edu](mailto:AuriaDR@lasc.edu)

Misty K. Blanks (2002)  
Instructor, Child Development Center  
B.A., California State University, Long Beach  
[BlanksMK@lasc.edu](mailto:BlanksMK@lasc.edu)

Monica Monge Garcia (2014)  
Director, Child Development  
Title IX Coordinator  
B.A., Pacific Oaks College,  
M.A., Pacific Oaks College  
[Morenomm2@lasc.edu](mailto:Morenomm2@lasc.edu)



# ENGLISH & FOREIGN LANGUAGE

School of Behavioral and Social Science Building (SSEC), Room 123  
(323) 241-5250  
[www.lasc.edu/students/departments/efl](http://www.lasc.edu/students/departments/efl)

Darren Cifarelli, Department Chair

Welcome to the English Department! The English Program is aimed at improving students' abilities to read, think, and write critically. Objectives in courses range from teaching the fundamentals of language to an introduction to significant literature in Western culture.

We offer an Associate's Degree and prepare students with professional, comprehensive, and rigorous training in writing for transfer to a university B.A. degree program with the writing, researching, and critical thinking skills necessary to succeed. The courses in the program are specifically designed to prepare students for study in English at a four-year university; with goals both educational and artistic, the English Program offers a multi-genre curriculum with foundation courses in critical thinking, writing, literature, fiction, nonfiction, drama, and poetry with additional options to take courses in African-American literature, Shakespeare, creative writing, journalism, and other specialized courses in literature and writing. Accentuated by active participation in student-centered classrooms, students learn strategies for participation in and facilitating workshops at the professional level.

In keeping with the mission of LASC, the English Program courses expand students' academic experiences that contribute to enrichment of life, affirmation of a diverse population, life-long learning, and enhanced critical thinking, and prepare them to enter a four-year university as English majors in pursuit of a B.A. degree.

Our campus has been increasingly responsive to numerous writing events and clubs hosted by the English Department; therefore, beyond the curriculum listed above, clubs and events on campus and in the local community designed to promote literacy through poetry, creative and academic writing, and journalism - such as poetry slams and guest author readings, and the Poetry Collective student club, the English Majors Club, the online school newspaper and Journalism club - have traditionally and consistently produced high student participation. Internships and jobs in journalism are available and needed locally, and our student clubs promote internships which would provide students with job experience and employers with interns as well as provide support for students majoring in English.

## ENGLISH

The English Program is aimed at improving students' abilities to read, think, and write critically. Objectives in courses range from teaching the fundamentals of language to an introduction to significant literature in Western culture.

The English Program offers three directions in which one can pursue his or her studies. One direction provides the basic courses that are required as partial fulfillment of the requirement for the Associate in Arts degree. A second direction provides the general education courses necessary for transferring to a four-year university. The third direction provides the basic freshman and sophomore courses required for the English major transferring to a four-year institution.

**Learning Outcomes:**

Read accurately, critically, broadly and reflectively, demonstrating the ability to consider contrastive or opposing perspectives and non-insular openness to diverse ideas and intellectual traditions.

Produce college-level academic English prose to communicate clear yet nuanced viewpoints on complex subjects and ideas, demonstrating a sound understanding of audience and prose.

## JOURNALISM

The Journalism Program is aimed at teaching students how to report and write the news, how to shoot news photographs, and how to design a college newspaper using computer technology.

Objectives of courses include learning the fundamentals of interview techniques and newspaper production.

**Learning Outcomes:**

Analyze the ethical concepts, legal implications, considerations and practices that guide online forums.

Apply tools and technologies appropriate for the production, editing and presentation of visual and textual, or other web-based content.

## FOREIGN LANGUAGE

The Foreign Language Program offers a sequence of courses in Spanish, which students can pursue for individual purposes. One direction provides courses which may be used as partial fulfillment of the requirement for the A.A. degree. A second direction provides the General Education courses necessary for transferring to a four-year university. A third direction provides the basic language courses required for the Spanish major transferring to a four-year institution.

The Program also offers classes for students who are interested in learning Spanish for use on their jobs or for vocational purposes. Native Spanish speakers may also take courses that enable them to improve their writing, reading, and speaking abilities.

**Learning Outcomes:**

Read a short story or article in Spanish and answer questions based on the reading.

Write an essay in Spanish of at least two pages using correct grammar and appropriate vocabulary.

## COMPETITION & PUBLICATIONS

### **Say the Word Essay and Poetry Competition**

Students may enter essays or poetry to the Say The Word Writing Competition. This year, we will accept essays and poetry on any subject. Winners in each category (essays and poetry) will receive cash prizes of \$100.00 for First Place and \$50.00 for Second Place. Both contest winners and selected entrants will be published in the current issue of *Say The Word Anthology of Student Writing*. Select poetry winners will be invited to read their poems at the Say The Word Event in Spring semester; select essay competition winners will be invited to read their work at the Anthology Publication Party the following Fall. Send submissions to [cifaredl@lasc.edu](mailto:cifaredl@lasc.edu) or submit hard copies to Professor Cifarelli's mailbox in the English Department.

**The Truth**

<http://lascsthetruth.weebly.com/>

The Truth is the LASC English Department’s online publication of creative writing by the students, staff, and faculty of Los Angeles Southwest College. The Truth is published to celebrate the literature and poetry of LASC. Students (and staff and faculty) are invited to submit creative work - poetry, short stories, long stories, novel excerpts, book reviews, lyrics, etc. - for publication in this online Literary Journal. You should also feel free to suggest a link for our links page or some audio or video poetry online for our Audio/ Video Poetry page. Send submissions to [cifaredl@lasc.edu](mailto:cifaredl@lasc.edu). Editing help is available by request.

**The Word**

[cifaredl@lasc.edu](mailto:cifaredl@lasc.edu)

Students (and staff and faculty) are encouraged to submit work for publication in our forthcoming online newspaper. Any writing that is topical, addresses a current event, reviews a film, CD, TV show, theatrical performance, or any other event, is an interview or portrait of a significant person, expresses an opinion about a current social issue or local events, is informative about community happenings, addresses a controversy in any discipline, provides advice, or anything else that might typically appear in a newspaper or make an interesting feature story...is welcome. Send submissions to [cifaredl@lasc.edu](mailto:cifaredl@lasc.edu). Editing help is available by request.

**Poetry Collective**

[lascpoetrycollective@gmail.com](mailto:lascpoetrycollective@gmail.com)

The Poetry Collective is a safe environment where you can share your work, thoughts, and feelings without any ridicule or judgment. You don’t have to be a poet to join. You can bring work from other poets to share. If you have any other talents such as drawing, music, etc., we’ll incorporate it into the organization. There are no fees or deadlines to join. We meet every 2nd and 4th Thursday of each month from 11am-12:30pm in SSEC 125-B. The collective looks great on scholarships, transfer applications, and resumes; it also provides opportunities to perform at on and off campus events as well as opportunities to publish your work in anthologies and chapbooks.

# English as a Second Language

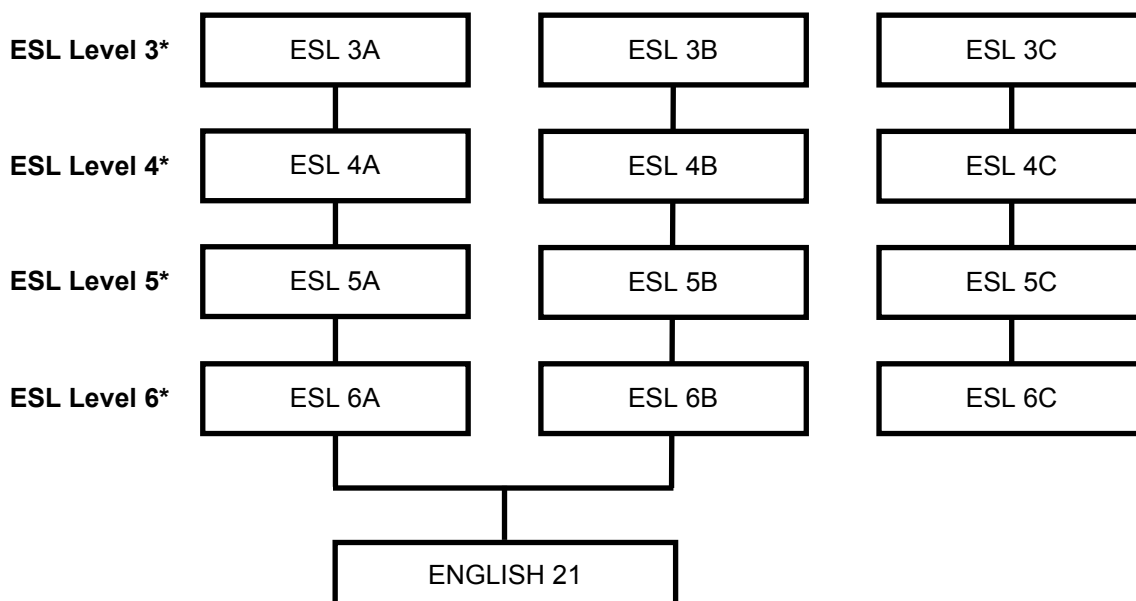



# ENGLISH COURSE FLOW CHART

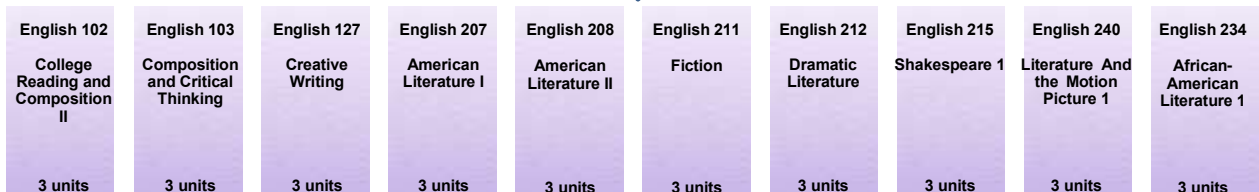
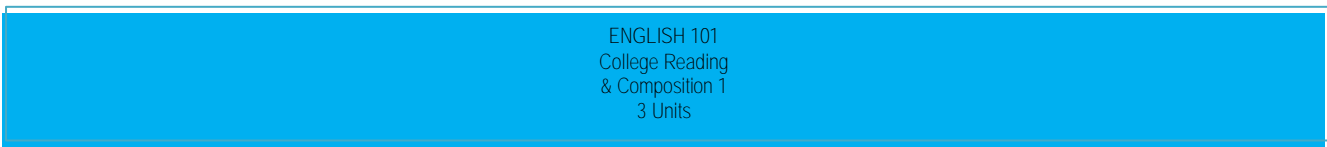
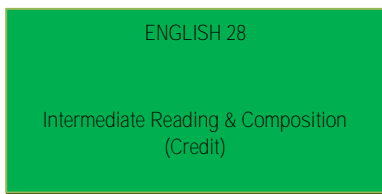
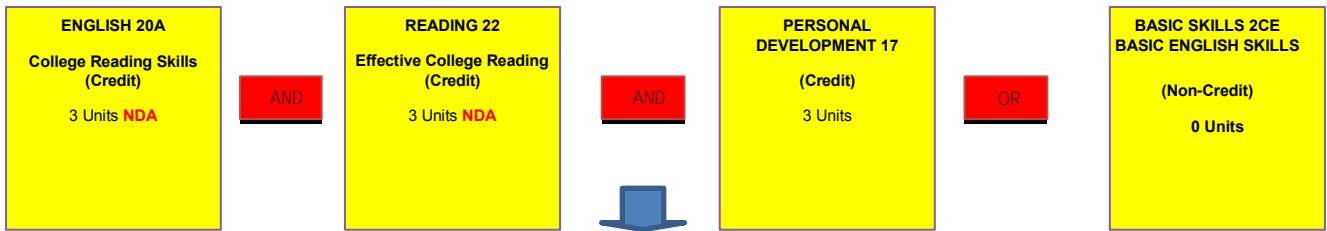

NDA= Non Degree applicable



# Faculty

**Stephanie Arms-Gradinton (2016)**  
 Assistant Professor, English  
 B. A., Clark Atlanta University,  
 M. A., California State University, Dominguez Hills  
[armss@lasc.edu](mailto:armss@lasc.edu)

**Jeffrey Bohn (2012)**  
 Instructor, English  
 B.A., California State University, Northridge  
 M.A., University of Southern California  
 Ph.D., University of Southern California  
[bohnjl@lasc.edu](mailto:bohnjl@lasc.edu)

**Stephanie Burrus (2011)**  
 Instructor, Reading  
 B.A., University of California, Los Angeles  
 M.A., California State University, Dominguez Hills  
[burrusd@lasc.edu](mailto:burrusd@lasc.edu)

**Darren Cifarelli (2008)**  
 English and Foreign Languages, Instructor, English  
 B.A., University of California, Los Angeles  
 M.A., California State University, Northridge  
[cifaredl@lasc.edu](mailto:cifaredl@lasc.edu)

**Sioban V. Dillon (2001)**  
 Professor, English  
 B.A., State University of New York, Albany  
 M.A., Binghamton University (SUNY)  
[DillonSV@lasc.edu](mailto:DillonSV@lasc.edu)

**Jessica Drawbond (2012)**  
 Instructor, English  
 B.A., California State University, Long Beach  
 M.A., California State University, Long Beach  
[drawbojn@lasc.edu](mailto:drawbojn@lasc.edu)

**Max Evans (2016)**  
 Assistant Professor, English  
 B.A., California State University, Long Beach  
 M.F.A., California State University, Long Beach  
[evansmd@lasc.edu](mailto:evansmd@lasc.edu)

**Kalunda Iwamzu (2016)**  
 Assistant Professor, English  
 B.A., University of Southern California, Los Angeles,  
 M.P.W., University of Southern California, Los Angeles  
[iwamizk@lasc.edu](mailto:iwamizk@lasc.edu)

**Phillip Jones-Thomas (1979)**  
 Professor, English & American Sign Language  
 B.A., University of Kansas  
 M.A., University of Illinois  
[jonespa@lasc.edu](mailto:jonespa@lasc.edu)

**Sharon Maselli (2000)**  
 Professor, English  
 B.A., California State University  
 M.A., University of Arizona  
 Ph.D., University of Arizona  
[MasellSA@lasc.edu](mailto:MasellSA@lasc.edu)

**Arabella C. Persaud (1990)**  
 Professor, Spanish  
 B.A., University of the West Indies  
 M.A., State University of New York  
 Ph.D., State University of New York  
[PersauA@lasc.edu](mailto:PersauA@lasc.edu)

**Sabrena Turner-Odom (2005)**  
 Associate Professor, English  
 A.A., Los Angeles Southwest College  
 B.A., University of Southern California  
 M.A., University of California, Irvine  
[OdomST@lasc.edu](mailto:OdomST@lasc.edu)

## ADJUNCT PROFESSORS

Billingslea, N..... English  
 Chiappelli, G.D ..... Spanish  
 Culver, A..... English  
 DeFrance, R..... English  
 Eckersley Jr., D.S..... English  
 Factor, H.J..... English  
 Felix, J..... English  
 Fetler, E.J..... English  
 Firpo, N..... English  
 Freedman, J..... English  
 Hall-Johnson, J. .... English  
 Haney, B..... English  
 Isaac, C ..... English  
 Isaac, L..... English  
 Lozada, C..... English  
 McClain, S..... English  
 McDuffie, A.L..... English

Ndoley, M.N. .... French  
 Norwood, P. .... English  
 Possemato, F ..... English  
 Roberts, M.T ..... English  
 Rubio, G.H..... English  
 Slama, J. .... English  
 Sun, G ..... Spanish  
 Ugas Abreus, B ..... Spanish  
 Viliesid, C ..... English  
 Zamora, V..... English

## DISCIPLINES

- English
- French
- Journalism
- Reading
- Spanish



# ASSOCIATE DEGREES

- English
- English AA-T
- Liberal Arts: English
- Journalism
- Journalism AA-T
- Spanish
- Spanish AA-T

complex subjects and ideas, demonstrating a sound understanding of audience and prose.

Required Courses	Units
ENGLISH 101 College Reading and Composition I.....	3
ENGLISH 102 College Reading and Composition II.....	3
ENGLISH 103 Composition and Critical Thinking.....	3

**Three of the following:**

ENGLISH 127 Creative Writing .....	3
ENGLISH 207 American Literature I.....	3
ENGLISH 211 Fiction.....	3
ENGLISH 212 Poetry.....	3
ENGLISH 213 Dramatic Literature .....	3
ENGLISH 215 Shakespeare .....	3
ENGLISH 234 African-American Literature I.....	3
ENGLISH 240 Literature and the Motion Picture.....	3
<b>TOTAL UNITS</b> .....	<b>18</b>

# SKILL CERTIFICATE

- Professional Spanish

## Associate in Arts Degree at LASC

Requirements are:

- Complete a minimum of 21 units of LACCD GENERAL EDUCATION REQUIREMENTS,
- Complete REQUIRED COURSES earning a "C" or better in each course
- Complete additional units chosen from RECOMMENDED ELECTIVES (where optioned),
- Complete a balance of degree-applicable electives, to total 60 units with a minimum of a 2.0 grade point average.

### Transfer Students

Completing the Associate Degree does not necessarily meet the university admission requirements for transfer. If you would like to transfer to a university, early educational planning can make this goal achievable. For information regarding the requirements to transfer to a University of California (UC), or California State University (CSU) campus, please consult with a counselor.

## ASSOCIATE in ARTS English

Student Learning Outcome: Upon completion of this program, students should be able to:

- Read accurately, critically, broadly and reflectively, demonstrating the ability to consider contrastive or opposing perspectives and non-insular openness to diverse ideas and intellectual traditions.
- Produce college-level academic English prose to communicate clear yet nuanced viewpoints on

## ASSOCIATE in ARTS in Arts in English for Transfer

The Associate in Arts in English for Transfer Degree is intended for students who are planning to transfer to a California State University (CSU) institution into the English Bachelors program. The Student is guaranteed admission to a CSU upon completion of this program. The Transfer Degree is designed to provide students with a Transfer Model Curriculum that is aimed at improving students' abilities to read, think, and write critically. Objectives in courses range from teaching the fundamentals of language to an introduction to significant literature in Western culture.

The intent of the Associate in Arts in English for Transfer Degree is to assist students in seamlessly transferring to CSU. Senate Bill (SB) 1440 and the California Education Code (CEC) section 66746 require students seeking an Associate in Arts in English for Transfer Degree to:

- Complete 60 semester units of 90-quarter units that are eligible for transfer to the California State University, including both of the following?
  - The Intersegmental General Education Transfer curriculum (IGETC) or the California State University General Education-Breadth Requirements
  - A minimum of 18 semester units or 27 quarter units in a major or area of emphasis, as determined by the community college district.
  - Minimum 18 units in the major
- Obtainment of a minimum grade point average of 2.0. ADTs also require that students must earn a C or better in all courses required for the major area of emphasis. A "P" (Pass) grade is not an acceptable grade for courses in the major.

Students should meet with a counselor to determine the necessary course work to complete the general education requirements.

Required Courses	Units
ENGLISH 102 College Reading and Composition II.....	3
ENGLISH 103 Composition and Critical Thinking .....	3
Select Two Courses	

ENGLISH 207	American Literature I .....	3
ENGLISH 208	American Literature II .....	3
Select One Course		
ENGLISH 212	Poetry .....	3
OR		
ENGLISH 127	Creative Writing .....	3
ENGLISH 211	Fiction .....	3
<b>TOTAL UNITS</b> .....		<b>18</b>

**ASSOCIATE in ARTS**  
**LIBERAL ARTS: English (non-transfer)**

Student Learning Outcome: Upon completion of this program, students should be able to:

1. Read accurately, critically, broadly and reflectively, demonstrating the ability to consider contrastive or opposing perspectives and non-insular openness to diverse ideas and intellectual traditions.
2. Produce college-level academic English prose to communicate clear yet nuanced viewpoints on complex subjects and ideas, demonstrating a sound understanding of audience and prose.

**Core Courses (Choose and complete 18 units):**

ENGLISH 101	College Reading and Composition I .....	3
ENGLISH 102	College Reading and Composition II .....	3
ENGLISH 103	Composition and Critical Thinking .....	3
ENGLISH 127	Creative Writing .....	3
ENGLISH 211	Fiction .....	3
ENGLISH 212	Poetry .....	3
ENGLISH 213	Dramatic Literature .....	3
ENGLISH 234	African-American Literature .....	3
ENGLISH 239	Women in Literature .....	3
<b>TOTAL UNITS</b> .....		<b>18</b>

**ASSOCIATE in ARTS**  
**Journalism**

Student Learning Outcome: Upon completion of this program, students should be able to:

- 1) Analyze the ethical concepts, legal implications, considerations and practices that guide online forums.
- 2) Apply tools and technologies appropriate for the production, editing and presentation of visual and textual, or other web-based content.

<b>Required Courses:</b>	<b>Units</b>	
ENGLISH 103	Composition and Critical Thinking .....	3
ENGLISH 111	Writing for New Media .....	3
ENGLISH 223	Creative Nonfiction .....	3
JOURN 101	Collecting and Writing News .....	3
JOURN 105	Mass Communications .....	3
JOURN 123	Convergent Journalism .....	3
<b>TOTAL UNITS</b> .....		<b>18</b>

**ASSOCIATE in ARTS**  
**in Journalism for Transfer**

The Associate in Arts in Journalism for Transfer Degree is intended for students who are planning to transfer to a

California State University (CSU) institution into the Journalism Bachelors program. The Student is guaranteed admission to a CSU upon completion of this program. The Transfer Degree is designed to provide students with a Transfer Model Curriculum is aimed at teaching students how to report and write the news, how to shoot news photographs, and how to design a college newspaper using computer technology. .

The Associate in Arts in Journalism for Transfer Degree requirements include: (1) completion of 60 CSU transferable units, including the minimum 18 units in the major and the completion of either IGETC or CSU GE; (2) a minimum GPA of 2.0. Students should meet with a counselor to determine the necessary course work to complete the general education requirements.

The intent of the Associate in Arts in Journalism for Transfer Degree is to assist students in seamlessly transferring to CSU into the Journalism Bachelors program.

Senate Bill (SB) 1440 and the California Education Code (CEC) section 66746 require students seeking the Associate in Arts in Journalism for Transfer Degree to:

- (1) Complete 60 semester units of 90-quarter units that are eligible for transfer to the California State University, including both of the following?
  - a. The Intersegmental General Education Transfer curriculum (IGETC) or the California State University General Education-Breadth Requirements
  - b. A minimum of 18 semester units or 27 quarter units in a major or area of emphasis, as determined by the community college district.
- (2) Obtainment of a minimum grade point average of 2.0. ADTs also require that students must earn a C or better in all courses required for the major area of emphasis. A "P" (Pass) grade is not an acceptable grade for courses in the major.

Students should meet with a counselor to determine the necessary course work to complete the general education requirements.

<b>Required Courses:</b>	<b>Units</b>	
JOURN 101	Collecting and Writing News .....	3
JOURN 105	Mass Communications .....	3
JOURN 123	Convergent Journalism .....	3
JOURN 217	Publication Laboratory .....	2
JOURN 219	Techniques For Staff Editors .....	1
Select Two Courses		
Math 227	Statistics .....	4
OR		
ECON 1	Principles Of Economics I .....	3
Or		
ECON 2	Principles Of Economics II .....	3
Or		
POL SCI 1	The Government Of The United States .....	3
Or		
POL SCI 2	Modern World Governments .....	3
Or		
ENGLISH 103	Composition and Critical Thinking .....	3
<b>TOTAL UNITS</b> .....		<b>19</b>

**ASSOCIATE in ARTS**  
**Spanish**





Student Learning Outcome: Upon completion of this program, students should be able to:

1. Read a short story or article in Spanish and answer questions based on the reading.
2. Write an essay in Spanish of at least two pages using correct grammar and appropriate vocabulary.

<b>Required Courses:</b>	<b>Units</b>
SPANISH 1 Elementary Spanish I .....	5
SPANISH 2 Elementary Spanish II .....	5
SPANISH 3 Intermediate Spanish I .....	5
SPANISH 4 Intermediate Spanish II .....	5
TOTAL UNITS .....	20

<b>Recommended Electives: Units</b>	
ART 101 Survey of Art History I .....	3
ART 102 Survey of Art History II .....	3
FRENCH 1 Elementary French I .....	5
FRENCH 2 Elementary French II .....	5
HISTORY 1 Introduction to Western Civilization I .....	3
HISTORY 2 Introduction to Western Civilization II .....	3
HISTORY 5 History of the Americas I .....	3
PHILOS 1 Introduction to Philosophy .....	3

**ASSOCIATE in ARTS  
in Spanish for Transfer**

The Associate in Arts in Spanish for Transfer Degree is intended for students who are planning to transfer to a California State University (CSU) institution into the Spanish Bachelors program. The Student is guaranteed admission to a CSU upon completion of this program. The Associate in Arts in Spanish for Transfer Degree is designed to provide students with a Transfer Model Curriculum which offers a sequence of courses in Spanish, which students can pursue for individual purposes. One direction provides courses which may be used as partial fulfillment of the requirement for the A.A. degree. A second direction provides the General Education courses necessary for transferring to a four-year university. A third direction provides the basic language courses required for the Spanish major transferring to a four-year institution.

The Program also offers classes for students who are interested in learning Spanish for use on their jobs or for vocational purposes. Native Spanish speakers may also take courses that enable them to improve their writing, reading, and speaking abilities.

The Associate in Arts in Spanish for Transfer Degree requirements include: (1) completion of 60 CSU transferable units, including the minimum 37-39 units in the major and the completion of either IGETC or CSU GE; (2) a minimum GPA of 2.0.

Students should meet with a counselor to determine the necessary course work to complete the general education requirements.

The intent of the Associate in Arts in Spanish for Transfer Degree is to assist students in seamlessly transferring to CSU.

Senate Bill (SB) 1440 and the California Education Code (CEC) section 66746 require students seeking an Associate in Arts in Spanish for Transfer for Transfer Degree to:

- (1) Complete 60 semester units of 90-quarter units that are eligible for transfer to the California State University, including both of the following?
  - a. The Intersegmental General Education Transfer curriculum (IGETC) or the California State University General Education-Breadth Requirements
  - b. A minimum of 18 semester units or 27 quarter units in a major

or area of emphasis, as determined by the community college district.

- (2) Obtainment of a minimum grade point average of 2.0. ADTs also require that students must earn a C or better in all courses required for the major area of emphasis. A "P" (Pass) grade is not an acceptable grade for courses in the major.

Students should meet with a counselor to determine the necessary course work to complete the general education requirements.

<b>Required Courses:</b>	<b>Units</b>
SPANISH 1 Elementary Spanish I .....	5
SPANISH 2 Elementary Spanish II .....	5
SPANISH 3 Intermediate Spanish I .....	5
SPANISH 4 Intermediate Spanish II .....	5
FRENCH 1 Elementary French I .....	5
TOTAL UNITS .....	25

**SKILL CERTIFICATE  
Professional Spanish**

Student Learning Outcome: Upon completion of this program, students should be able to:

**Required Courses:**

SPANISH 1 Elementary Spanish I .....	5
SPANISH 2 Elementary Spanish II .....	5
SPANISH 14 Spanish for Public Service Personnel.....	3
OR	
SPANISH 24 Spanish for Medical Personnel .....	3
SPANISH 8 Conversational Spanish .....	2
<b>TOTAL UNITS .....</b>	<b>15</b>

# MATHEMATICS

Technology Education Building, Room 281

(322) 241- 5366

[www.lasc.edu/students/departments/math/mathdepartment.html](http://www.lasc.edu/students/departments/math/mathdepartment.html)

Dr. Lernik Saakian, Department Chair

The department is located on the second floor of the Technology Education Center and consists of nine full-time and about 30 part-time, faculty members.

The department offers a full spectrum of courses from basic mathematics through Statistics, Calculus, Linear Algebra, and Differential Equations to meet the needs of students with a wide variety of goals.

Courses are scheduled throughout the day and evening from 7:45 a.m. to 9 p.m. Monday through Thursday. Courses are also offered on Fridays and Saturdays. The Math Lab is staffed with experienced instructors and student tutors and offers a wide variety of tutoring services, including workshops.

The Mathematics Department at LASC is committed to making your math experience the best possible!

## Faculty

### Dimetros W. Dammerna (2016)

Associate Professor, Mathematics  
B.S., California State University, Long Beach  
M.S., California State University, Long Beach  
[dammendw@lasc.edu](mailto:dammendw@lasc.edu)

### Zekarias W. Dammerna (1999)

Associate Professor, Mathematics  
B.S., Technical University of Dresden, Germany  
M.A., California State University, Long Beach  
[DammenZW@lasc.edu](mailto:DammenZW@lasc.edu)

### Deyanira Elias (2012)

Instructor, Mathematics  
A.A., East Los Angeles College  
B.A., California State University, Los Angeles  
M.S., California State University, Los Angeles  
[eliasd@lasc.edu](mailto:eliasd@lasc.edu)

### Edward Hector (1997)

Associate Professor, Mathematics  
A.A., Los Angeles Southwest College  
B.A., University of California, Los Angeles  
M.S., Howard University  
Ph.D., Capella University  
[HectorE@lasc.edu](mailto:HectorE@lasc.edu)

### Irina Gromova (2012)

Instructor, Mathematics  
M.S. The Novosibirsk Institute of Electrical Engineering  
[gromovi@lasc.edu](mailto:gromovi@lasc.edu)

### Martin Martirosian (2016)

Instructor, Mathematics  
M.S. 1978 Yerevan State University  
[martim@lasc.edu](mailto:martim@lasc.edu)

### Guadalupe Ramos (2008)

Instructor, Mathematics  
A.A., East Los Angeles College  
B.A., California State University, Los Angeles  
M.S., California State University, Los Angeles  
[ramosga@lasc.edu](mailto:ramosga@lasc.edu)

### Lernik Saakian (1999)

Instructor, Mathematics, Physics  
M.S., Academy of Science of USSR  
Ph.D., Academy of Science of USSR  
[SaakianL@lasc.edu](mailto:SaakianL@lasc.edu)

### Gizaw, T. Tadele (2001)

Associate Professor, Mathematics  
B.S., Addis Ababa University  
M.S., Addis Ababa University  
[tadelegt@lasc.edu](mailto:tadelegt@lasc.edu)



# MATH SEQUENCE

## OVERVIEW OF MATH COURSES OFFERED

### Basic Skills 35CE (0 Units)–Basic Math Skill (Formerly Math 105)

This noncredit course is designed to strengthen basic Math skills. Topics include rounding, estimating, computing whole numbers, fractions, decimals and presents.



### Basic Skills 28CE (0 Units)–Basic Skills Pre-Algebra (Formerly Math 112)

This noncredit course bridges the gap between arithmetic and algebra. It reviews arithmetic and introduces concepts of algebra including signed numbers, variables, exponents, mathematical sentences and linear equations. Concepts, computational skills and problem-solving skills are introduced and practiced to build mastery and proficiency.



### Math 115 (5 Units) – Elementary Algebra

This is the equivalent of 1<sup>st</sup> year high school algebra, done in one semester required for an A.A. degree (may be taken by exam).



### Math 125 (5 Units) – Intermediate Algebra

The equivalent of 2<sup>nd</sup> year high school algebra, done in one semester. To earn a bachelor's degree at a CSU, students must either pass a CSU math test beyond the Math 125 level or take a math course beyond Math 125.

### Math 122 (5 Units) – Intermediate Algebra for Statistics (General Education)

Math 122 is designed as the prerequisite course for students (Liberal and Social Science majors) who are required to complete Math 227 (Statistics) for

#### Math 215 (3 Units)\*

Principles of Mathematics I

#### Math 216 (3 Units)\*

Principles of Mathematics II

#### Math 230 (3 Units)\*

Mathematics for Liberal Arts Students

#### Math 235 (3 Units)\*

Finite Mathematics

#### Math 240 (3 Units)\*

Trigonometry

#### Math 236 (5 Units)\*

Calculus for Business and Social Science

#### Math 245 (3 Units)\*

College Algebra

#### Math 260 (5 Units)\*

Pre-Calculus Prerequisite Math 240

#### Math 227 (4 Units)\*

Statistics

#### Math 265 (5 Units)

Calculus with Analytic Geometry I  
Prerequisite: Math 240 and 245 or Math 260

#### Math 266 (5 Units)

Calculus with Analytic Geometry II  
Prerequisite: Math 265

#### Math 267 (5 Units)

Calculus with Analytic Geometry III  
Prerequisite: Math 266

#### Math 270 (3 Units)

Linear Algebra  
Prerequisite: Math 266

#### Math 275 (3 Units)

Ordinary Differential Equations  
Prerequisite: Math 266

**\*NOTE: MATH 125 IS THE PREREQUISITE FOR MATH 215, 227, 230, 235, 236, 240 and 245**

## ADJUNCT PROFESSORS

Agassi, N.....	Mathematics
Arutyunyan, A.....	Mathematics
Barsegian, G.....	Mathematics
Carbonell, J.....	Mathematics
Chang, Y.....	Mathematics
Chen, G.....	Mathematics
Clark, V.....	Mathematics
Gharamanians, J.....	Mathematics
Gizaw, A.....	Mathematics
Hall, L.....	Mathematics
Hovhannisyan, V.....	Mathematics
Huynh, D.....	Mathematics
Jiang, J.....	Mathematics
Minasian, A.....	Mathematics
Nash, B.....	Mathematics
Nguyen, G.....	Mathematics
Nguyen, H.....	Mathematics
Obrenovic, K.....	Mathematics
Oganyan, K.....	Mathematics
Patvakanyan, Y.....	Mathematics
Sarkisian, E.....	Mathematics
Selezinka, R.....	Mathematics

## DISCIPLINES

- Mathematics
- Physics

## ASSOCIATE DEGREES

- Mathematics
- Mathematics AS-T
- Mathematics: Computer Science

### ASSOCIATE in ARTS DEGREE at LASC

Requirements are:

- Complete a minimum of 21 units of LACCD GENERAL EDUCATION REQUIREMENTS,
- Complete REQUIRED COURSES earning a "C" or better in each course,
- Complete additional units chosen from RECOMMENDED ELECTIVES (where optioned),
- Complete a balance of degree-applicable electives, to total 60 units with a minimum of a 2.0 grade point average.

### Transfer Students

Completing the Associate Degree does not necessarily meet the university admission requirements for transfer. If you would like to transfer to a university, early educational planning can make this goal achievable. For information regarding the requirements to transfer to a University of California (UC), or California State University (CSU) campus, please consult with a counselor.

### ASSOCIATE IN ARTS Mathematics

Student Learning Outcome:

Upon completion of this program, students should be able to:

- Solve word problems by following the problem solving strategy method. Declare variable(s), set up equation(s), solve equation(s), and express answer as a sentence/phrase in English (with at least 70% success rate).
- Solve systems of linear equations by graphing, and algebraic methods (with at least 65% success rate).
- 3) Graph a linear, quadratic, polynomial, rational, exponential, log, and trigonometric functions (with at least 65% success rate).
- Evaluate the first and second derivatives of a given function (with at least 65% success rate).
- Determine whether a pair of functions are linearly independent or dependent on the real numbers (with at least 65% success rate).

#### Required Courses:

	Units
MATH 265	Calculus with Analytic Geometry I ..... 5
MATH 266	Calculus with Analytic Geometry II ..... 5
MATH 267	Calculus with Analytic Geometry III ..... 5
MATH 275	Ordinary Differential Equations ..... 3
	<b>TOTAL UNITS ..... 18</b>

#### Recommended Electives

CHEM 101	General Chemistry I ..... 5
CHEM 102	General Chemistry II ..... 5
CO SCI 608	Beginning BASIC Programming ..... 3
MATH 270	Linear Algebra ..... 3
PHYSICS 37	Physics for Engineers and Scientists I ..... 5
PHYSICS 38	Physics for Engineers and Scientists II ..... 5
PHYSICS 39	Physics for Engineers and Scientists III ..... 5

### ASSOCIATE IN SCIENCE In Mathematics for Transfer

The Associate in Science in Mathematics for Transfer Degree is intended for students who are planning to transfer to a California State University (CSU) institution into the Mathematics Bachelors program. The Student is guaranteed admission to a CSU upon completion of this program. The Associate in Science in Mathematics for Transfer Degree is designed to provide students with a Transfer Model Curriculum and develop student's skills in differential and integral calculus, linear algebra, differential equations, and statistics. The Associate in Science in Mathematics for Transfer Degree is designed to prepare students for transfer into the CSU.



The intent of the Associate in Science in Mathematics for Transfer Degree is to assist students in seamlessly transferring to CSU.

Senate Bill (SB) 1440 and the California Education Code (CEC) section 66746 require students seeking an Associate in Science in Business Administration for Transfer Degree to:

(1) Complete 60 semester units of 90-quarter units that are eligible for transfer to the California State University, including both of the following?

- a. The Intersegmental General Education Transfer curriculum (IGETC) or the California State University General Education-Breadth Requirements
- b. A minimum of 18 semester units or 27 quarter units in a major or area of emphasis, as determined by the community college district.
- c. Minimum 21-22 units in the major

(2) Obtainment of a minimum grade point average of 2.0. ADTs also require that students must earn a C or better in all courses required for the major area of emphasis. A "P" (Pass) grade is not an acceptable grade for courses in the major. Students should meet with a counselor to determine the necessary course work to complete the general education requirements.

Students should meet with a counselor to determine the necessary course work to complete the general education requirements.

**Recommended Electives Units**

CHEM 101	General Chemistry I .....	5
CO SCI 636	Introduction to Data Structures .....	3
CO SCI 639	Programming in C .....	3
MATH 227	Statistics .....	4
MATH 275	Ordinary Differential Equations .....	3
PHYSICS 37	Physics for Engineers and Scientists I .....	5
PHYSICS 38	Physics for Engineers and Scientists II .....	5
PHYSICS 39	Physics for Engineers and Scientists III .....	5

<b>Required Courses:</b>	<b>Units</b>
MATH 227 Statistics .....	4
MATH 265 Calculus with Analytic Geometry I .....	5
MATH 266 Calculus with Analytic Geometry II .....	5
MATH 267 Calculus with Analytic Geometry III .....	5
MATH 270 Linear Algebra .....	3
MATH 275 Ordinary Differential Equations .....	3
<b>TOTAL UNITS</b> .....	<b>21-22</b>

**ASSOCIATE IN ARTS IN  
Mathematics: Computer Science**

Student Learning Outcome:

Upon completion of this program, students should be able to:

1. Write a program on an object oriented interface in Visual Basic (with at least 65% success rate).
2. Solve systems of linear equations by graphing, and algebraic methods (with at least 65% success rate).
3. Graph a linear, quadratic, polynomial, rational, exponential, log, and trigonometric functions (with at least 65% success rate).
4. Evaluate the first and second derivatives of a given function (with at least 65% success rate).
5. Determine whether a pair of functions are linearly independent or dependent on the real numbers (with at least 65% success rate).

<b>Required Courses:</b>	<b>Units</b>
CO SCI 608 Beginning BASIC Programming .....	3
MATH 265 Calculus with Analytic Geometry I .....	5
MATH 266 Calculus with Analytic Geometry II .....	5
MATH 267 Calculus with Analytic Geometry III .....	5
MATH 270 Linear Algebra .....	3
<b>TOTAL UNITS</b> .....	<b>21</b>

# NATURAL SCIENCES, HEALTH & KINESIOLOGY

Academic Village, Room 101  
 (323) 241-5296  
[www.lasc.edu/students/departments/nspe/index.html](http://www.lasc.edu/students/departments/nspe/index.html)

Dr. Todd Roberts, Department Chair

The department is located in the Academic Village (AV). Our primary goal is to provide access through this multicultural, international and intercultural community via a collegiate experience that promotes equity for all. The department's programs appeal to both the traditional and non-traditional student, offer equal opportunity for participation in all disciplines, provide comprehensive transfer and career programs, and maintain high enrollment and retention as well as high completion ratios.

We provide an environment of diversity to meet the specific needs of the South Los Angeles community we serve. We have energetic and committed faculty and staff who inspire students to reach their goals. Necessary skills for student success in both academic and career segments of student education are provided in Anatomy, Biology, Chemistry, Microbiology, Physiology, Health, Kinesiology, Physics, Geology and Geography disciplines.

The purpose of our department and function is in concert with the core values of our institution: access, success, excellence, accountability, collaboration and resources, and career and technical education.

## Faculty

**Sharon Collins-Head (1997)**  
 Professor, Dance, Health & Physical Education  
 A.A., El Camino College  
 B.A., California State University, Dominguez Hills  
 M.A., California State University, Long Beach  
[CollinSK@lasc.edu](mailto:CollinSK@lasc.edu)

**Paul R. Doose (2000)**  
 Professor, Earth Sciences  
 B.S., University of California, Los Angeles  
 M.S., University of California, Los Angeles  
 Ph.D., University of California, Los Angeles  
[DoosePR@lasc.edu](mailto:DoosePR@lasc.edu)

**Robert E. Estrada (2015)**  
 Associate Professor, Kinesiology  
 B.S., Johnson C. Smith University  
 M.S., University of Central Missouri  
[estradre@lasc.edu](mailto:estradre@lasc.edu)

**Brian Gamble (2015)**  
 Instructor, Physics  
 B.S., The Citadel: The Military College of South Carolina  
 MS., North Carolina State University  
 Ph.D., Clemson University  
[gamblebk@lasc.edu](mailto:gamblebk@lasc.edu)

**Kang Kim (1996)**  
 Professor, Natural Sciences  
 B.S., University of California, Los Angeles  
 M.S., California State University, Los Angeles  
[KimK@lasc.edu](mailto:KimK@lasc.edu)

**Todd Roberts (2000)**  
 Professor, Biology & Physiology  
 MB.S., University of California, Davis  
 M.S., University of Georgia  
 Ph.D., University of Georgia  
[RobertTJ@lasc.edu](mailto:RobertTJ@lasc.edu)

**Robert Stewart (2008)**  
 Assistant Professor, Anatomy & Biology  
 B.S., California State University, Dominguez Hills  
 M.S., California State University, Los Angeles  
[stewartrl@lasc.edu](mailto:stewartrl@lasc.edu)

**Erum Syed (2012)**  
 Associate Professor, Microbiology  
 B.S., Baqai Medical University  
 M.S., Clemson University, SC  
[syeden@lasc.edu](mailto:syeden@lasc.edu)

**Heidi Tatum (2015)**  
 Assistant Professor Health Science  
 AA, Los Angeles Southwest College,  
 B.S., Cal State Dominguez Hills  
 M.S., Cal State Dominguez Hills  
[tatumhl@lasc.edu](mailto:tatumhl@lasc.edu)

**Pogban Toure (2009)**  
 Instructor, Chemistry  
 M.A., University of Abidjan  
 M.S., Florida Institute of Technology  
 Ph.D., University of California, Santa Barbara  
[tourep@lasc.edu](mailto:tourep@lasc.edu)

**Henry Washington (1982)**  
 Head Football Coach, Physical Education  
 B.A., University of Redlands  
 M.A., Brigham Young University  
[WashinH@lasc.edu](mailto:WashinH@lasc.edu)



## ADJUNCT PROFESSORS

Alcocer, B.....	Kinesiology
Amos, B.....	Physics
De, R.....	Physical Science
Elfarissi, H.....	Biological Sciences
Fielding, L.....	Geology, Geography
Garnett, F.....	Health
Hass, J.....	Biological Sciences
Henderson, J.....	Health, Kinesology
Huber-Lytal, S.....	Biological Sciences
Mak, P.....	Biological Sciences
Mitchell, T.....	Kinesiology
Nagaya, M.....	Biological Sciences
Naqvi, H.....	Biological Sciences
Olsen, B.....	Biological Sciences
Oswald, S.....	Biological Sciences
Resendiz, R.....	Biological Sciences
Rodriguez, K.....	Biological Sciences
Romero, R.....	Chemistry
Souki, S.....	Biological Sciences
Teclé, H.....	Biological Sciences
Vara, J.....	Kinesiology
Wahba, R.....	Biological Sciences
Watkins, P.....	Health

## STAFF

Bingham, Wilda.....	Athletic Trainer
Dace, Stella.....	Secretary
Dilliard, La'Nette.....	Women's Basketball Coach
Elfarissi, Hassan.....	Life Science Lab Technician
Elfarissi, Kamal.....	Life Science Lab Technician
Franklin, Mickey.....	Chemistry Lab Technician
Stayton, Wynton.....	Physical Science Laboratory Technician

## DISCIPLINES

- Anatomy
- Biology
- Chemistry
- Dance
- Environmental Science

- Environmental Studies
- Geography
- Geology
- Health
- Kinesiology
- Microbiology
- Physical Science
- Physics
- Physiology

## ASSOCIATE DEGREE

- Biology
- Geography
- Geology
- Liberal Arts: Natural Sciences
- Physics
- Physics AS-T

### Associate in Arts Degree at LASC

Requirements are:

- Complete a minimum of 21 units of LACCD GENERAL EDUCATION REQUIREMENTS,
- Complete REQUIRED COURSES earning a "C" or better in each course,
- Complete additional units chosen from RECOMMENDED ELECTIVES (where optioned),
- Complete a balance of degree-applicable electives, to total 60 units with a minimum of a 2.0 grade point average.

### Transfer Students

Completing the Associate Degree does not necessarily meet the university admission requirements for transfer. If you would like to transfer to a university, early educational planning can make this goal achievable. For information regarding the requirements to transfer to a University of California (UC), or California State University (CSU) campus, please consult with a counselor.

**ASSOCIATE in SCIENCE**  
**Biology**



PLO 1 - Students will apply the scientific method to solve a problem.

PLO 2 - Students will solve problems utilizing the major concepts in cell biology and the experimental approaches taken to address them.

**Required Courses:**

	<b>Units</b>
BIOLOGY 6 General Biology I .....	5
BIOLOGY 7 General Biology II .....	5
CHEM 101 General Chemistry I .....	5
CHEM 102 General Chemistry II .....	5
PHYSICS 6 General Physics I .....	4
PHYSICS 7 General Physics II .....	4
<b>TOTAL UNITS</b> .....	<b>28</b>

**Recommended Electives Units**

BIOLOGY 5 Introduction to Human Biology .....	4
CHEM 211 Organic Chemistry for Science Majors I .....	5
CHEM 212 Organic Chemistry for Science Majors II .....	5
MATH 227 Statistics .....	4
MICRO 1 Introductory Microbiology .....	5

**ASSOCIATE IN SCIENCE**

**Geography**

PLO 1 - Students can recognize and articulate how geography affects their lives.

PLO 2 - Students will be able to explain the basic concepts of geography.

**Required Courses:**

	<b>Units</b>
BIOLOGY 3 Introduction to Biology .....	4
CHEM 101 General Chemistry I .....	5
GEOG 1 Physical Geography .....	3
GEOG 2 Cultural Elements of Geography .....	3
MATH 227 Statistics .....	4
<b>TOTAL UNITS</b> .....	<b>19</b>

**ASSOCIATE IN SCIENCE**

**Geology**

PLO 1 - Demonstrate understanding of the basic concepts in subject areas.

PLO 2 - Demonstrate technical skills in the collection and analysis of geologic data, Critical-Thinking skills, plus written and verbal Communication skills.

PLO 3 - Apply geologic knowledge and skills to a range of problems faced by business, industry, government.

**Required Courses:**

	<b>Units</b>
BIOLOGY 3 Introduction to Biology .....	4
CHEM 101 General Chemistry I .....	5
GEOLOGY 1 Physical Geology .....	3
GEOLOGY 6 Physical Geology Laboratory .....	2
PHYSICS 37 Physics for Engineers and Scientists I .....	5
<b>TOTAL UNITS</b> .....	<b>19</b>

**Recommended Electives Units**

CHEM 102 General Chemistry II .....	5
CO SCI 608 Beginning BASIC Programming .....	3
MATH 227 Introductory Statistics .....	4

MATH 265	Calculus with Analytic Geometry I .....	5
MATH 266	Calculus with Analytic Geometry II .....	5
PHYSICS 38	Physics for Engineers and Scientists II .....	5
PHYSICS 39	Physics for Engineers and Scientists III .....	5

**ASSOCIATE IN ARTS**

**LIBERAL ARTS: Natural Sciences**

PLO 1 - Students will apply the scientific method to solve a problem.

PLO 2 - Students will comprehend and evaluate content relating to human body structure, function, and disease.

**Core Courses (Choose and complete 18 units):**

BIOLOGY 3	Introduction to Biology .....	4
BIOLOGY 5	Introduction to Human Biology .....	4
BIOLOGY 6	General Biology I .....	5
BIOLOGY 7	General Biology II .....	5
ANATOMY 1	Introduction to Human Anatomy .....	4
AND		
PHYSIOL 1	Introduction to Human Physiology .....	4
OR		
BIOLOGY 20	Human Anatomy and Physiology .....	8
CHEM 51	Fundamentals of Chemistry I .....	5
CHEM 101	General Chemistry I .....	5
CHEM 102	General Chemistry II .....	5
GEOLOGY 1	Physical Geology .....	3
GEOLOGY 6	Physical Geology Laboratory .....	2
MICRO 1	Introductory Microbiology .....	5
PHYSICS 6	General Physics I .....	4
PHYSICS 7	General Physics II .....	4
PHYS SC 1	Physical Science I .....	3
PHYS SC 14	Physical Science Laboratory .....	1

**ASSOCIATE IN SCIENCE**

**Physics**

PLO 1 - Students are able to solve kine-matic problems (mechanical and electrical) (90%) using equations of dynamics, work-energy relation, electromagnetism, and Newton's laws.

PLO 2 - Students are able to explain apparently obvious real-life (physical) phenomena (90%) using basic laws of Physics.

PLO 3 - Students understand the technologies (80%) based on Physics and employed in specified fields like medicine, dentistry, architecture etc.

PLO 4 - Students develop logical thinking together with scientific approaches to problem solving.

**Required Courses:**

		<b>Units</b>
CHEM 101	General Chemistry I .....	5
CHEM 102	General Chemistry II .....	5
MATH 260	Pre-Calculus .....	5
MATH 265	Calculus with Analytic Geometry I .....	5
MATH 266	Calculus with Analytic Geometry II .....	5
MATH 267	Calculus with Analytic Geometry III .....	5
MATH 270	Linear Algebra .....	3
MATH 275	Ordinary Differential Equations .....	3
PHYSICS 37	Physics for Engineers and Scientists I .....	5
PHYSICS 38	Physics for Engineers and Scientists II .....	5





PHYSICS 39	Physics for Engineers and Scientists III .....	5
<b>TOTAL UNITS</b> .....		<b>51</b>

### ASSOCIATE IN SCIENCE in Physics for Transfer

The Associate in Science in Physics for Transfer Degree is intended for students who are planning to transfer to a California State University (CSU) institution into the Physics Bachelors program. The Student is guaranteed admission to a CSU upon completion of this program. The Associate in Science in Physics for Transfer Degree is designed to provide students with a Transfer Model Curriculum in all aspects of the physical universe are of interest to the physicist, who seeks to understand not only the smallest forms of matter and the rich phenomena present in our everyday lives but also the universe itself. The tools of the physicist include observation, imagination, model building, prediction, and deduction. The Associate in Science in Physics for Transfer degree is designed to provide the skills, understanding, and outlook required for participation in the discovery of new knowledge about nature.

The intent of the Associate in Science in Physics for Transfer Degree is to assist students in seamlessly transferring to CSU. Senate Bill (SB) 1440 and the California Education Code (CEC) section 66746 require students seeking the Associate in Science in Physics for Transfer Degree to:

- (1) Complete 60 semester units of 90-quarter units that are eligible for transfer to the California State University, including both of the following?
    - a. The Intersegmental General Education Transfer curriculum (IGETC) or the California State University General Education-Breadth Requirements
    - b. A minimum of 18 semester units or 27 quarter units in a major or area of emphasis, as determined by the community college district.
    - c. Minimum 24 units in the major
  - (2) Obtainment of a minimum grade point average of 2.0.
- ADTs also require that students must earn a C or better in all courses required for the major area of emphasis. A "P" (Pass) grade is not an acceptable grade for courses in the major.

Students should meet with a counselor to determine the necessary course work to complete the general education requirements.

<b>Required Courses:</b>		<b>Units</b>
PHYSICS 37	Physics for Engineers and Scientists I.....	5
PHYSICS 38	Physics for Engineers and Scientists II .....	5
PHYSICS 39	Physics for Engineers and Scientists III .....	5
MATH 265	Calculus with Analytic Geometry I .....	5
MATH 266	Calculus with Analytic Geometry II .....	5
<b>TOTAL UNITS</b> .....		<b>25</b>

# NURSING

Academic Village, Room 104

(322) 241- 5461

[www.lasc.edu/faculty\\_staff/nursing/nursing\\_prog\\_info.html](http://www.lasc.edu/faculty_staff/nursing/nursing_prog_info.html)

Dr. Catherine Azubuike, Nursing and Allied Healthcare Program Director/  
Department Chair

## About Nursing at LASC

Our nursing program has a history of excellence in the preparation of competent Registered Nurses. The Associate Degree Registered Nursing program is approved by the California Board of Registered Nursing (BRN). In 2012, the BRN granted continuing approval for the maximum length of time allowed. LASC School of Nursing offers quality education with an emphasis on critical thinking skills needed to apply theoretical concepts to clinical nursing practice. LASC offers extensive support services.



## Faculty

### Catherine Ugo Azubuike (1998)

Department Chair, Nursing & Allied Health, Professor of Nursing  
(Medical/Surgical Nursing)  
A.D.N., Cerritos College  
B.S., Texas Southern University, BSN, University of Phoenix  
M.S.N., University of Phoenix  
DNP, Western University of Health Sciences  
[AzubuiCU@lasc.edu](mailto:AzubuiCU@lasc.edu)

### Nkonye Ezeobah (2000)

Associate Professor, Nursing  
B.S.N., University of Ibadan, Nigeria  
M.S.N., Azusa Pacific University  
PHN., California State University, Dominguez Hills, FNP, University  
of Southern California, PH.D., International University for Graduate  
Studies  
[EzeobaNP@lasc.edu](mailto:EzeobaNP@lasc.edu)

### Indiana McClellan (2008)

Instructor, Nursing  
A.D.N., Los Angeles Harbor College  
B.S.N., California State University, Dominguez Hills  
M.S.N., California State University, Dominguez Hills  
[gabbidim@lasc.edu](mailto:gabbidim@lasc.edu)

### Rosa Song (2010)

Instructor, Nursing  
A.D.N., College of the Canyons  
B.A., University of Texas, Austin  
M.S.N., Mount Saint Mary's College  
[songre@lasc.edu](mailto:songre@lasc.edu)

### Lorna Thompson (2010)

Instructor, Medical/Surgical Nursing  
A.A., Los Angeles Southwest College  
B.S.N., Holy Names University  
M.S.N., Walden University  
[thompsli2@lasc.edu](mailto:thompsli2@lasc.edu)

### Victoria Omuson (2012)

Nursing Instructor  
B.S.N., University Of Phoenix  
M.S.N., California State University, Dominguez Hills  
PMHNP, California State University, Long Beach,  
DNP, Walden University  
[omusonv@lasc.edu](mailto:omusonv@lasc.edu)

### Elizabeth Wider (2016)

Instructor, Nursing  
A.D.N., East Los Angeles College  
B.A. Anthropology California State University, Los Angeles  
M.A. California State University, Northridge, M.S.N., California State  
University, Dominguez Hills  
EDD, University of Phoenix  
[widerej@lasc.edu](mailto:widerej@lasc.edu)



## ADJUNCT PROFESSORS

Lydia Ajao.....	RN, M.S.N., CNS
Maureen Akpofure-Ojose .....	RN, MSN, FNP
Chona, Biteng.....	R.N., B.S.N
Charity Chibueze.....	RN, MSN
Nancy De La Cruz.....	R.N., B.S.N
Norma Haye .....	R. N., M.S.N
Bridgette Holt-Carter .....	R.N.M.S.N
Sheila Joshway .....	RN, MSN
Dr. Gerald, Tcheumani.....	RN, MSN, DNP
Georgina Walker .....	R.N, B.S.N, RRT, PA
Marion White .....	R.N., B.S.N.
Dr. Eric Williams.....	RN, M.S.N, DNP, CNE

## STAFF

Quentina Banks .....	Program Assistant
Aracely Martinez .....	Senior Office Assistant
Norma Torres .....	Nursing Counselor
Dr. Elma Tulloch- Reid, EdD .....	Instructional Assistant

## ASSOCIATE DEGREE

- Nursing

## CERTIFICATES OF ACHIEVEMENT

- Certified Nursing Assistant/Home Health Aide

## Educational Program

The Associate Degree Nursing Program at Los Angeles Southwest College is one that demands high levels of performance and proficiency. It effectively integrates general education with the basics of Nursing theory and practice. The curriculum provides two options: 1) the “Generic Option” which requires students to earn an Associate in Science degree; and 2) the “30-Unit Option,” mandated by the Board of Registered Nursing, which does not require the students to earn a degree. Upon completion of either option, the student is eligible to take the NCLEX-RN (National Council Licensure Examination for Registered Nurses). Once passed, the student becomes a Registered Nurse (R.N.) in the state of California.

Information regarding program cost is available in the office of the Nursing Department, which is located in Academic Village #104. Financial aid is available to help most students with their expenses. Aid includes tuition waivers, grants and college work-study. Additional information and assistance regarding finances is available in the Financial Aid Office in SSB 104. After successful completion of the first semester of the Nursing Program, students are eligible to take the Certified Nursing Assistant Examination and seek employment in a health care agency.

Students seeking admission to the Nursing program are required to see the Nursing Counselor in AV 104 to review and complete an Educational Plan. Enrollment in the Associate Degree Nursing Program requires acceptance as a fully matriculated student at Los Angeles Southwest College.

If a student has a prior record of conviction of a serious offense, the student is urged to contact the Board of Registered Nursing before applying to the Nursing Program. It is the responsibility of the Board to protect the public against unsafe practitioners by limiting licensure. Even if a student has successfully completed a course of study, the Board may still refuse to grant a license. Further clarification may be obtained by contacting the Board of Registered Nursing; 1625 N. Market Boulevard; Suite N-217; Sacramento, CA 95834; [www.rn.ca.gov](http://www.rn.ca.gov) (916) 322-3350.

Each student enrolled in a Nursing Program in the Los Angeles Community College District must complete and have on file with the Nursing Program office a clear criminal background check in order to participate in placement(s) in clinical facilities. **The background check is not a requirement for admission to the Nursing Program. It is a clinical facility requirement made to comply with Joint Commission on Accreditation of Healthcare Organizations.** It is to be completed once the student receives the acceptance for admission.

Communication with the Nursing Department is primarily done by mail and email. It is the responsibility of each applicant to make sure the department has his/her current address and phone number on file.

## Program Standards

In order to apply to the Nursing Program, a student must have achieved a cumulative grade point average (GPA) of 2.5 or higher for all college coursework taken. In addition, a grade of “C” or higher is required in all Nursing Prerequisite courses. These standards are required for application to both the “Generic Option” and the “30-Unit Option” programs. Once admitted, a student may enroll in a class in the Nursing Program only two times. For this purpose, enrollment is defined as attending at least one class meeting. Note that a “W” is considered a fail in all Nursing courses. As per E-10 guideline, **only one class** in the Nursing Program may generally be repeated. Continuing students must maintain a 2.0 cumulative grade point average.

## Transfer Students

- Transfer students from other nursing programs will be evaluated on an individual basis. This process requires a completed application, college catalog, letter from the former program director and course syllabi for all successfully completed nursing courses.
- Transfer students must meet the admission requirements for LASC Nursing Program's Generic Nursing Students. **Transfer students must also follow the same application procedure as general students in order to apply to the program.** Space for transfer students is very limited.
- Please contact the Nursing Department to see if transfer students are being accepted at this time.

## Challenging Coursework through Credit by Examination

A maximum of 15 units may be earned through Credit by Examination and applied toward an Associate Degree. A student wishing to take the first or any other Nursing course must be officially admitted to the Generic Nursing Program and have completed at least 12 units within the Los Angeles Community College District. Application for Credit by Examination must be made in writing and exams taken in sequential order. Evaluation is done individually of each application and accompanying documentation of past education and experience. If the application to take an exam is approved, a study guide will be provided prior to the test. The student will then be registered in the course and tuition must be paid. If the student passes the exam, credit will be issued.

A Licensed Vocational Nurse who wishes to receive selected Nursing credits through examination must possess a current California Vocational Nursing License. A career ladder option, however, is not offered.

## Challenge - Advanced Placement into the Nursing Education Program for Military Personnel

### Challenge/Advanced Placement for Military-Trained Health Care Personnel Policy:

Individuals who have documented military education and experience in health care occupations may be eligible for advanced placement. Please review and follow the policies below.

- Individuals who have documented military education and experience in health care occupations may be eligible for advanced placement into the LACCD nursing programs.
- Documentation of education and clinical experience for military health care occupations must demonstrate satisfactory completion of education and experience. Official transcript(s) **and** documentation of experience (on official letterhead) must be submitted.
- Applicants must meet all general entrance requirements of the Associate Degree Nursing program, including completion of designated prerequisites and achievement of required cut score on nursing readiness entrance examination (Test of Academic Skills (**TEAS**)).
- Acceptance of military challenge/advanced placement students into the Associate Degree Nursing Program is contingent upon space availability.
- Applicants must adhere to the challenge policy and procedure, as stated in the Student Handbook and College Catalog (Petition for Credit by Examination) and as stated below:

### LASC POLICY – Petition for Credit by Examination

1. A maximum of 15 units may be earned through Credit by Examination and applied toward an Associate Degree.
2. A student wishing to take the first semester or any other Nursing Course must be officially admitted to the generic Nursing Program and have completed at least 12 units within the Los Angeles Community College District
3. Application for Credit by Examination must be made in writing and exams taken in sequential order.
4. The student must be enrolled and pay all fees.
5. The current established theory and clinical course outlines, objectives, learning activities and recommended readings in the course/s being challenged will be used.
6. The examination criteria, theory and clinical, will be the same criteria currently established for the specific course/s being challenged.
7. The theory challenge examination must be passed at **75%** or higher before the clinical portion can be challenged.
8. The clinical portion must be passed as "Satisfactory." If the clinical portion results in "failure," the whole course being **challenged must be taken.**

Theory, clinical and skills lab must be passed to receive a grade for the course.

- F. Applicants must follow the required steps to apply to the LASC nursing program (see below).

### **Required Steps to Apply to the Nursing Program**



The Los Angeles Southwest College Nursing Program accepts applications **twice a year: July 15- September 15, for the Spring filing period and January 15-March 15, for the Fall filing period.**

In order to obtain a Program Application, the following steps **MUST** be completed **well in advance** of the application filing period:

1. All students who have never applied to Southwest College need to submit a college application to the LASC Admissions Office. International students must first apply to the International Student Program.
2. All U.S. transcripts outside of the Los Angeles Community College District (LACCD) must be mailed directly from the college attended to the LASC Admissions Office. Hand-carried U.S. transcripts of any kind are **NOT** acceptable. Students must confirm with the Nursing Counseling that transcripts have arrived prior to making a counseling appointment.
3. All transcripts outside of the U.S. must be evaluated according to the following procedures:
  - Must complete 12 units with a “C” average within the LACCD **prior** to submitting any petition for credit.
  - Submit foreign transcripts to an LASC-approved foreign transcripts evaluation service to obtain credit recommendations.
  - LASC will not accept foreign transcript credit conferred by another college toward program pre-requisites.
  - Submit to the college’s Petitions Committee a sealed copy of the evaluation service’s credit recommendations along with a petition for approval of credit. Credit approval by the Petitions Committee is **NOT** automatic (see a counselor for details).
4. Schedule an appointment with the nursing counselor to evaluate your transcripts **well in advance of the application deadline and only after completion of Steps 1 through 3.** The counselor will provide students with a signed “Evaluation of Transcripts for Nursing Program Prerequisites” form verifying that all Nursing Program prerequisites are completed with a “C” or better, before applying to the nursing program during the application period.

**LASC Challenge/Advanced Placement for Military-Trained Health Care Personnel Procedure:**

1. The petitioner must:
  - Satisfy the rules and regulations established in the LASC policy for petitioning for credit for examination (refer to current LASC catalog for the established criteria)
  - Have satisfactorily completed the pre-requisites of the nursing course/s being challenged
  - Submit to the Department Chairperson documentation of all previous course work and /or experience/s that the petitioner believes qualifies him/her for course credit by examination
2. The petition, document and recommendations of the Chair will be presented and discussed with the Nursing Program’s Policy/Admission committee at the next regularly scheduled meeting.
3. The Nursing Policy/Admission committee will determine eligibility.
4. Qualified applicants will be contacted by the examiner following the decision of the Policy/Admission committee advising:
  - The date the course materials will be available
  - Suggested dates and location of the examination
  - Dates of scheduled clinical experiences that include development of nursing care plans;(nursing care plans will be grades as Pass/Fail)
5. A letter grade will be given upon completion of the theory and clinical examination. The student will be notified of the grade achieved for the course. If the student passes the exam, credit will be issued.
6. The petitioner will be informed of his /her grade and the grade will be submitted to the Admission and Records Office.

**Approved by the LACCD Nursing District Discipline Committee: 04/13/16**

**Schedule**

The Nursing Program requires clinical experience that will be observed at local hospitals and other health care settings in the community. All clinical experience is coordinated with classroom instruction. Lecture hours will be assigned.

**ASSOCIATE IN SCIENCE  
Nursing**

Student Learning Outcome: Upon completion of this program, students should be able to:

1. Pass the National Council Licensure Examination for licensed registered nursing (NCLEX-RN).
2. Be prepared for employment as an entry level licensed registered nurse.
3. Use critical thinking and nursing standards to plan and deliver effective nursing care to clients with stable health conditions within structured health care settings.
4. Use effective written and oral communications with clients, family members and the health care team.
5. Provide culturally centered care that respects the clients' health beliefs, values and practices.
6. Demonstrate the ability to function in a collaborative manner as a member of a multidisciplinary health care team.
7. Demonstrate professional behaviors and practices within the legal and ethical framework of a licensed registered nurse.
8. Assume responsibility for ongoing learning and professional growth.

<b>Prerequisite Courses and Requirements:</b>		<b>Units</b>
BIOLOGY 3	Introduction to Biology .....	4
	OR	
BIOLOGY 5	Introduction to Human Biology ....	4
ANATOMY 1	Introduction to Human Anatomy .	4
	AND	
PHYSIOL 1	Introduction to Human Physiology .....	4
	OR	
BIOLOGY 20	Human Anatomy and Physiology	8
	AND all the following:	
Chemistry 51	Fundamentals of Chemistry .....	5
*Micro 1	Introductory Microbiology .....	5
English 101	College Reading & Composition I .....	3
COMM 101	Oral Communication 1 .....	3
PSYCH 1	General Psychology 1 .....	3
PSYCH 41	Life-Span Psychology From Infancy to Old Age .....	3
SOC 1	Introduction to Sociology .....	3
MATH 115	Elementary Algebra .....	5
(or higher) or Successful completion of Math Competency Test. Completion of appropriate Chemistry prerequisite is required for R.N. Candidates (Chemistry 51 or higher)		

**First Year Courses:**

<b>First Semester</b> .....		<b>Units</b>
NURS 501A	Fundamentals of Nursing A.....	4.5
NURS 501B	Fundamentals of Nursing B.....	4.5
NURS 526	Communication in Nursing .....	1
NURS 527	Nursing Process .....	1

**Second Semester**

NURS 502A	Medical-Surgical Nursing A .....	4.5
NURS 503B	Psychiatric Nursing .....	4.5
NURS 185	Directed Studies .....	1

**Second Year Courses:**

<b>First Semester</b>		<b>Units</b>
NURS 506B	Maternal and Child Health Nursing (Obstetrics) .....	4.5

NURS 506A	Maternal and Child Health Nursing (Pediatrics) .....	4.5
NURS 285	Directed Studies.....	2

**Second Semester**

NURS 502B	Medical-Surgical Nursing B.....	4.5
NURS 503A	Advanced Medical-Surgical Nursing .....	4.5
NURS 507	Senior Seminar .....	1
NURS 385	Directed Studies.....	3
<b>TOTAL UNITS</b> .....		<b>45</b>

*\*Note: Consult the Nursing Department for the sequence of nursing courses.*

<b>LACCD GE Requirements:</b> .....		<b>Units</b>
Humanities	.....	3
American Institution	.....	3
Kinesiology	.....	1
Math 125	.....	5

*Graduates of this Nursing Program are exempt from the college general education requirement in Health.*

**CERTIFICATE OF ACHIEVEMENT  
Certified Nursing Assistant/Home Health Aide**

Courses in Health Occupations are designed for students who wish to enter one of the many health career programs in the Los Angeles Community College District and/ or prepare for a job in a related health care position in the Los Angeles area. These courses serve as the foundational knowledge base to enter the Certified Nursing Assistant (CNA) and Certified Home Health Aide (HHA) courses and to achieve Certificates of Achievement in each. The Certified Nursing Assistant (CNA) certificate prepares students for a career in an area with a high demand for employment. The CNA provides basic nursing care for patients in hospitals, assisted living, or long-term care. The CNA course consists of both classroom and clinical experiences. The course covers basic theory and skills such as patient rights, interpersonal skills, infection control, emergencies, body mechanics, patient care skills and procedures, vital signs, nutrition, observation and charting, long-term care, and rehabilitation. The program is approved by the California Department of Public Health. Upon successful completion of the course, students are eligible to apply to take the state of California certification examination for CNA.

<b>Required Courses:</b>		<b>Units</b>
HLTHOCC 62	Skill Set for the Health Care Professional .....	2
HLTHOCC 63	Basic Medical Terminology, Pathophysiology and Pharmacology .....	2
HLTHOCC 64	Cultural and Legal Topics for Health Care Professionals.....	1
HLTHOCC 65	Fundamentals for the Health Care Professional.....	2.5
NURS 399A	Nurse Assistant Training Program .....	5
NURS 399B	Home Health Aide Training Program .....	2
<b>TOTAL UNITS</b> .....		<b>14.5</b>



## Admission Requirements – Generic Option

A United States high school diploma or its equivalent is required. The G.E.D. test or the California High School Proficiency Examination may meet equivalency. A degree from a college or university in the United States may also meet this requirement., as well as an evaluated foreign transcript. **An overall grade point average of 2.5 for the Human Anatomy, Human Physiology, and Microbiology prerequisite courses with no grade less than “C” for each course and no more than one repetition of any of these courses is required.**

Candidates must complete all of the Nursing prerequisites with a grade of “C” or better. Candidates must be in good standing academically and not on academic or progress probation.

Students must be free from communicable diseases, infection, psychological disorders, and other conditions that present a threat to, or negatively impact, the wellbeing of faculty, other students, and consumers and/or would prevent the successful performance of responsibilities and tasks required in the Nursing Education Program.

Each student is required to have a completed physical exam prior to admission and the exam must be completed yearly. Students are also required to have the following tests: complete blood count, VDRL or RPR, urinalysis, evidence of polio vaccination, and annual TB skin test and/or x-ray.

Additionally, students must demonstrate, by titers, the immunity from rubella, rubella, varicella, hepatitis B and mumps. Students may choose to waive immunization for hepatitis B by completing a signed disclaimer provided by the Nursing Department. Students must satisfy any additional requirement of affiliating facilities.

Copies of all laboratory and immunization results must be submitted with the completed Health Record Card prior to admission to the first required Nursing course. Students must bear cost of all tests, immunizations, and the physical examination.

Students must present a current Health Care Provider Cardiopulmonary Resuscitation (CPR) Certificate. The certifying course must include adult, child, and infant CPR, and airway management information and competencies.

Student liability insurance is required prior to participation in the clinical component of all Clinical Nursing courses. Application for the insurance is provided during the orientation session for officially admitted students.

Nursing students are asked to join the national and local chapters of the National Student Nurses’ Association. Application for this organization is also provided during the orientation session for officially admitted students.

Program costs and transportation to off-campus clinical sites is the responsibility of the student. In addition, enrolled students are required to take a series of mandatory content mastery examinations after the completion of each semester of the nursing program. The approximate cost is \$3,800.00 over the entire program.

Candidates must take the ATI TEAS tests to demonstrate math computation proficiency and reading speed, proficiency and comprehension. Assistance is available to help students achieve the required skill levels prior to enrolling in the first Nursing course. Testing date, time, and

location is mailed to eligible students. Completion of college-level Chemistry courses is a prerequisite to Microbiology courses.

Officially admitted Nursing students may be suspended from the Nursing Program on a case-by-case basis for health and safety reasons or for violations of the Los Angeles Community College District’s Standards of Conduct. Students may also be expelled from an affiliating clinical agency when the student is felt by the agency to have violated his/her contractual health and safety and professional standards.

## Nursing Admission and Selection Process Policy

Completion of all the required prerequisites for the nursing program as stipulated in the E-10 Guideline and maintains a minimum of 2.5 GPA in all the Science courses and 2.5 in the overall nursing prerequisite courses.

Attend one of the nursing information session, the dates are posted on the nursing website at: [www.lasc.edu/nursing](http://www.lasc.edu/nursing)

Obtain and complete the application and return it to the Nursing Office along with: (1) Verification of U.S. High School Graduation, G.E.D., California Proficiency Examination or U.S. College or University Degree, or an evaluated foreign transcript; and (2) Official Transcripts from all previous Colleges and Universities, including Los Angeles Southwest College. Please check the Nursing website for application deadlines.

Applications are screened by the nursing counselor and the senior office assistant for: (1) Completion of prerequisite courses, (2) GPA verification, (3) Repeat Policy, and other necessary requirements and deadlines.

Candidates who meet the entire admission requirement are scheduled to take the TEAS (Test of Essential Academic Skills) Examination. Dr. Elma Tulloch-Reid proctors the TEAS Test in the Computer lab located in the LASC Tech Building.

All candidates are required to take the “Test of Essential Academic Skills” (TEAS) version 5 (V) or the most current version at the time of application period. **The LASC College Benchmark score is 62%.** Candidates who have taken the TEAS previously, **MUST** see the nursing department for directions on providing scores along with the application.

Students who have taken TEAS before but did not score a 62% in the overall score, must re-take the TEAS within one year period, but **must** score a 62% in all the sub areas (English, Reading, Math, and Sciences). Candidates who have taken the TEAS previously **must** request an official transcript to be sent to the nursing department directly.

Upon completion of the TEAS Test, the Nursing Counselor and the senior office assistant will compile the qualified candidates who are eligible to be admitted into the nursing program.

The compiled list will be delivered to the Nursing Program Director for final checks and balances, the Nursing Program Director will then send the eligible candidates to the nursing faculty admission



committee with the nursing counselor for the lottery selection.

Each semester, following the application deadline, the most qualified candidates are admitted to the Nursing Program. In the event the Nursing program has received applications for more than the allotted seats, the selection process is done by **lottery process** by the admission committee members.

#### **AFTER ADMISSION:**

All candidates accepted into the Nursing Program **MUST** attend a **mandatory all day** Nursing orientation meeting. If a student does not attend the mandatory orientation meeting his/her position will immediately be given to an alternate candidate. Also, there will be a six-week orientation to Nursing class (Nursing 520) and Nursing Boot Camp (Nursing 540). Both are offered during the winter Intercession for spring, summer and fall terms. These courses are highly recommended.

All classes in the Nursing Program must be completed with a "C" or better grade in order to advance to the next course within the program and to earn the degree of Associate Degree in Science in Nursing. As per E-10 guideline, only one class- in the Nursing Program may generally be repeated. In addition, enrolled students are required to take a series of mandatory Kaplan content mastery examinations after the completion of each course in the Nursing Program.

After a student is admitted into the Nursing Program, a full time load is considered a minimum of 9 units per semester. A drug dosage and calculation test is given the last week of each nursing course, in preparation for the next level course.

### **Nursing Curriculum - 30-Unit Option**

The California Board of Registered Nursing mandates this option, and candidates completing it are eligible to take the National Council of State Boards of Nursing Examination (NCLEX) to acquire licensure as a Registered Nurse in the State of California. Other states may not recognize this option as valid preparation for R.N. licensure and, therefore, not grant interstate licensure.

Individuals completing this option are not graduates of Los Angeles Southwest College's Nursing Program and are not eligible to wear the program's cap or pin. The Associate Degree in Science with a specialization in Nursing is not awarded upon completion of the 30-Unit Option.

A grade of "C" or better is mandatory for all courses required in the 30-Unit Option. Applicants are admitted on a space available basis.

<b>Required Prerequisite Courses:</b>	<b>Units</b>
PHYSIOL 1 Introduction to Human Physiology	4
MICRO 1 Introductory Microbiology	5
<b>Required Nursing Courses:</b>	<b>Units</b>
NURS 518 Patient Care Seminar for Transfer Students	2
NURS 526 Communication in Nursing	1
NURS 527 Nursing Process	1
NURS 503A Advanced Medical-Surgical Nursing	4.5
NURS 503B Psychiatric Nursing	4.5
NURS 507 Senior Seminar	1

NURS 502B Medical-Surgical Nursing

4.5

### **Application Process**

Students selecting this option should obtain an application from the Nursing Department Office, complete the application and write on the front of the form in the upper right corner, "30 Unit Option." Return the application to the Nursing Department Office along with: 1) verification of a current California LVN license; 2) verification of U.S. high school graduation, G.E.D., or California Proficiency Examination; 3) official college transcripts listing the required prerequisite courses; 4) Education Plan completed by a college counselor at Los Angeles Southwest College.

Candidates selecting this option are also required to take the Nursing Department's tests to demonstrate math computation and reading speed, proficiency and comprehension. Assistance is available to help students achieve the required skill levels prior to enrolling in the first Nursing course.

### **Admission Requirements**

1. Completion of all health, immunization and laboratory tests required for students enrolled in the generic Nursing Program.
2. Professional liability insurance.
3. CPR certification for health care providers, which includes adult, child, and infant airway management information and competencies





## FACULTY AND ADMINISTRATION

Abdullah, Kaaran (1997)  
Professor, Child Development Center  
B.S., California State University, Northridge

Alfred, Tangelia M. (2005)  
Dean, Curriculum, Natural Sciences,  
Health, Kinesiology, and Mathematics  
B.A., California State University Bakersfield  
M.A., San Diego State University  
Ed.D., California State University Long Beach

Apenahier, Leonard E. (1996)  
Associate Professor, Psychology  
B.S., University of Oregon  
M.A., Pepperdine University  
M.S., Vanderbilt University  
Ph.D., Howard University

Amos, Gail (2016)  
Assistant Professor  
B.A., Christian Leadership University,  
B.A., Pacific Oaks College  
M.A., Pacific Oaks College  
Ed.D., Walden University

Arms-Gradinton, Stephanie (2016)  
Assistant Professor, English  
B. A., Clark Atlanta University,  
M. A., California State University, Dominguez  
Hills

Auria, Debra R. (2000)  
Associate Professor, Child Development  
Center  
A.A., Los Angeles Harbor College  
B.A., California State University, Dominguez  
Hills

Azubuikwe, Catherine Ugo (1998)  
Department Chair, Nursing & Allied  
Health, Professor of Nursing (Medical/  
Surgical Nursing)  
A.D.N., Cerritos College  
B.S., Texas Southern University  
BSN, University of Phoenix  
M.S.N., University of Phoenix  
DNP, Western University of Health Sciences,  
Pomona California

Blanks, Misty K. (2002)  
Instructor, Child Development Center  
B.A., California State University, Long Beach

Bohn, Jeffrey (2012)  
Instructor, English  
B.A., California State University, Los Angeles  
M.S., California State University, Los Angeles  
Ed.D., University of Southern California

Bradford, Lawrence L. (2014)  
Vice President, Academic Affairs  
B.A., California State University, Northridge  
M.A., University of Southern California  
Ph.D., University of Southern California

Brady, Linda (2005)  
Librarian  
Double B.A., California Baptist University,  
Riverside, CA  
M.L.I.S., San Jose State University

Bremen, Jonathan (2009)  
Instructor, Music  
B.A., Sonoma State University  
M.M., Indiana University  
D.M.A., University of Southern California

Brinson, LaShawn L (2002)  
Department Chair, Child Development  
and Family and Consumer Studies  
B.A., California State University, Northridge  
M.A., Pacific Oaks College

Burrus, Stephanie (2011)  
Instructor, Reading  
B.A., University of California, Los Angeles  
M.A., California State University, Dominguez  
Hills

Calderon, Rose (1999)  
Director EOPS/CARE Programs,  
Counselor  
B.S., Loyola Marymount University  
M.S., University of La Verne

Cifarelli, Darren (2008)  
Department Chair, English and Foreign  
Languages, Instructor, English  
B.A., University of California, Los Angeles  
M.A., California State University, Northridge

Collins-Heads, Sharon (1997)  
Professor, Dance, Health & Physical  
Education  
A.A., El Camino College  
B.A., California State University, Dominguez  
Hills  
M.A., California State University, Long Beach

Dammena, Dimetros W. (2016)  
Associate Professor, Mathematics  
B.S., California State University, Long Beach  
M.S., California State University, Long Beach

Dammena, Zekarias W. (1999)  
Associate Professor, Mathematics  
B.S., Technical University of Dresden,  
Germany  
M.A., California State University, Long Beach

Davis, Ralph (2012)  
Counselor  
B.A., Stanford University  
M.S.Ed., University of Pennsylvania

Dillon, Sioban V., (2001)  
Professor, English  
B.A., State University of New York, Albany  
M.A., Binghamton University (SUNY)

Doose, Paul R., (2000)  
Professor, Earth Sciences  
B.S., University of California, Los Angeles  
M.S., University of California, Los Angeles  
Ph.D., University of California, Los Angeles

Drawbond, Jessica (2012)  
Instructor, English  
B.A., California State University, Long Beach  
M.A., California State University, Long Beach

DuBry, Travis A. (2016)  
Assistant Professor, Anthropology  
B.S. University of California, Riverside  
M.A. University of California, Riverside  
Ph.D. University of California, Riverside

Duncan, Yancy (2016)  
Assistant Professor, Communication  
Studies  
B.A., California State University, Los Angeles  
M.A., California State University, Los Angeles

El-Khoury, Naja (2009)  
Instructor, Computer Science and  
Information Technology  
B.S., National University, San Diego  
M.B.A., National University, Los Angeles  
M.S., National University, Los Angeles

Elias, Deyanira (2012)  
Instructor, Math  
A.A., East Los Angeles College  
B.A., California State University, Los Angeles  
M.S., California State University, Los Angeles

Estrada, Robert E. (2015)  
Associate Professor, Kinesiology  
B.S., Johnson C. Smith University  
M.S., University of Central Missouri

Evans, Lauren (2016)  
Instructor, Fine Arts  
B.F.A., University of Southern California  
M.F.A., University of Southern California

Evans, Max (2016)  
Assistant Professor, English  
B.A., California State University, Long Beach  
M.F.A., California State University, Long  
Beach

Ezeobah, Nkonye (2000)  
Associate Professor, Nursing  
B.S.N., University of Ibadan, Nigeria  
M.S.N., Azusa Pacific University  
PHN., California State University, Dominguez  
Hills  
FNP, University of Southern California  
PH.D., International University for Graduate  
Studies  
Certified Chemical Dependency Counselor

Farber, Deborah (2016)  
Assistant Professor  
B.A., California Lutheran University  
M.A., San Jose State University

Ford, Lisa D. (2004)  
Counselor, Instructor, Personal  
Development  
B.A., California State University, Long Beach  
M.S., California State University, Los Angeles

Gallegos, Jose A. (2016)  
Dean, Institutional Advancement  
B.A., California State University Los Angeles  
M.A., California State University Los Angeles

Gamble, Brian (2015)  
Instructor, Physics  
B.S., The Citadel: The Military College of  
South Carolina  
MS., North Carolina State University  
PhD., Clemson University

Garcia, Monica Monge (2014)  
Director, Child Development  
Title IX Coordinator  
B.A., Pacific Oaks College,  
M.A., Pacific Oaks College

Garcia-Oliva, Claudia E. (2015)  
Assistant Professor, Child Development  
A.A. Child Development Los Angeles City  
College  
B.A., California State University, Los Angeles  
M.A., California State University, Los Angeles

Greene, Voiza (2012)  
Associate Professor, Speech  
Communication  
B.A., *California State University, Los Angeles*  
M.A., *California State University, Los Angeles*

Gonzalez, Christina I. (2016)  
Counselor  
B.A., *California State University, Los Angeles*  
M.S., *California State University, Los Angeles*

Gromova, Irina (2012)  
Instructor, Mathematics  
M.S. *The Novosibirsk Institute of Electrical  
Engineering*

Haghoo, Majid (1999)  
Professor, Computer Science  
and Information Technology  
M.S., *University of Southern California*  
Ph.D., *University of Southern California*

Hall, Daniel B. (2016)  
Vice President, Administrative Services  
B.S., *Willamette University, Salem, Oregon*  
M.B.A., *University of Oregon, Eugene*

Haynes, Ronald (1976)  
Counselor, Professor  
B.S., *University of Missouri*  
M.Ed., *University of Missouri*

Hector, Edward (1997)  
Associate Professor, Mathematics  
A.A., *Los Angeles Southwest College*  
B.A., *University of California, Los Angeles*  
M.S., *Howard University*  
Ph.D., *Capella University, Minneapolis*

Hicks, James E. (1998)  
Professor, Computer Science and  
Information Technology  
B.S., *Morgan State University*  
M.S., *University of Wisconsin*  
M.S., *University of California, Los Angeles*

Hodge, Rick (2014),  
Dean, Career & Technical Education  
(Workforce)  
B.S., *University of Oregon*  
B.A., *Walla Walla College*  
M.Div., *Andrews University*

Howard, Tamura (2008)  
Department Chair, Behavioral & Social  
Sciences, Instructor, Political Science  
B.A., *California State University, Long Beach*  
M.A., *University of California, Los Angeles*  
Ph.D., *University of California, Los Angeles*

Irvin, Howard (2016)  
Vice President, Student Services  
A.A. - *San Diego Mesa College*  
B.S. - *San Diego State University*  
M.S. - *San Diego State University*  
M.A. - *Fielding Graduate University*  
Ph.D. - *Fielding Graduate University*

Iwamzu, Kalunda (2016)  
Assistant Professor, English  
B.A., *University of Southern California, Los  
Angeles*,  
M.P.W., *University of Southern California,  
Los Angeles*

Jones, Maisha (2015)  
Associate Professor, Sociology  
M.A., *California State University at  
Dominguez Hills*

Jones-Thomas, Phillip (1979)  
Professor, English & American Sign  
Language  
B.A., *University of Kansas*  
M.A., *University of Illinois*

Juarez, Monica M. (2013)  
Assistant Professor, Child Development  
B.A., *University of Redlands*  
M.A., *Pacific Oaks College*

Kim, Kang (1996)  
Professor Natural Sciences  
B.S., *University of California, Los Angeles*  
M.S., *California State University, Los Angeles*

Lee, Janice E. (1978)  
Professor, Counselor  
B.A., *California State University, Los Angeles*  
M.S., *California State University, Los Angeles*

Lee, Sandra (1999)  
AFT Chapter President  
Associate Professor, Psychology  
B.A., *University of California, Los Angeles*  
M.Ed., *University of Louisville*  
M.A., *University of Louisville*  
Ph.D., *University of Louisville*

Magee, Carolyn (1989)  
Professor, Computer Applications &  
Office Technology  
B.S., *University of Southern Mississippi*  
M.A., *California State University, Los Angeles*

Mantena, Niladri R. (1996)  
Professor, Electronics & Computer  
Technology  
B.S., *Andhra University, Waltair, AP, India*  
B.S.E.E., *Madras Institute of Technology,  
Chromepet, India*  
M.S., *Indian Institute of Technology,  
Kharagpur, WB, India*  
Ph.D., *University of California, Berkeley*

Martirossian, Martin (2016)  
Instructor, Mathematics  
M.S. 1978 *Yerevan State University*

Maselli, Sharon (2000)  
Professor, English  
B.A., *California State University*  
M.A., *University of Arizona*  
Ph.D., *University of Arizona*

McBride, Kimberly (2008)  
Instructor, Developmental  
Communications  
B.S., *Howard University*  
M.A., *Pepperdine University*  
M.S., *University of LaVerne*

McClellan, Indiana (2008)  
Instructor, Nursing  
A.D.N., *Los Angeles Harbor College*  
B.S.N., *California State University,  
Dominguez Hills*  
M.S.N., *California State University,  
Dominguez Hills*

Miller-Washington, Erika L. (2005)  
Director/Counselor, TRIO Scholars  
B.S., *Howard University*  
M.A., *Pepperdine University*

Moore, Allison P. (2001)  
Dean ,Arts & Humanities, Behavioral &  
Social Science, Distance Education,  
English & Foreign Language, and Li-  
brary  
B.S., *University of Southern California*  
M.Acc., *University of Southern California*  
D.P.A., *University of LaVerne*

Morris, Reginald (2016)  
Dean, Student Services  
A.A., *Los Angeles, Harbor College*  
B.S., *San Jose State University*  
M.A., *California Lutheran College*

Mrava, Joanne (1974)  
Professor, Business Administration  
*Business Education, Administration of Justice*  
B.S., *University of Southern California*  
M.S., *University of Southern California*  
A.A., *Long Beach City College*

Noldon, Denise (2016)  
Interim President  
B.A. *California State University, Long Beach*  
M.S. *California State University, Long Beach*  
Ph.D. *University of Maryland at College Park*

Omuson, Victoria (2012)  
Nursing Instructor  
B.S.N, *University Of Phoenix*  
M.S.N, *California State University,  
Dominguez Hills*  
PMHNP, *California State University, Long  
Beach*,  
DNP, *Walden University*

Ortega, Daniel (2008)  
Counselor, Instructor, Personal Devel-  
opment, Co-Coordinator, Puente Pro-  
gram  
B.A., *University of California, Los Angeles*  
M.S., *California State University, Long Beach*  
Ph.D., *Claremont Graduate University*

Persaud, Arabella C. (1990)  
Professor, Spanish  
B.A., *University of the West Indies, Jamaica*  
M.A., *State University of New York, Buffalo*  
Ph.D., *State University of New York, Buffalo*

Pope-Evans, Jonathon (2016)  
Assistant Professor, Theater Arts  
B.F.A., *William Carey College*  
M.F.A., *California Institute of the Arts*

Powell, Wonda (1979)  
Professor, History, Business  
B.S., *University of Michigan*  
M.A., *University of California, Los Angeles*

Ramos, Guadalupe (2008)  
Instructor, Mathematics  
A.A., *East Los Angeles College*  
B.A., *California State University, Los Angeles*  
M.S., *California State University, Los Angeles*

Ream, Timothy (2015)  
Librarian  
B.A., *University of California, Los Angeles*  
M.L.I.S., *San Jose State University*



Robert, Lance A. (2015)  
Instructor, Political Science  
*B.A., University of California, Santa Barbara*  
*MPA, California State University, Long Beach*  
*DPA, Capella University*

Roberts, Todd J. (2000)  
Department Chair, Professor, Biology & Physiology  
*B.S., University of California, Davis*  
*M.S., University of Georgia*  
*Ph.D., University of Georgia*

Robinson, Dawn (2015)  
Assistant Professor, Child Development  
*B.A., Sonoma State University*  
*M.A., Mills College*

Rodriguez, Blanca (2010)  
Counselor  
*B.A., California State University, Northridge*  
*M.A., California State University, Dominguez Hills*

Ruane, Marian (1990)  
Noncredit Program Coordinator  
*B.A., San Diego State University*  
*M.A., Loyola Marymount University*

Saakian, Lernik (1999)  
Chair, Mathematics  
Instructor, Mathematics, Physics  
*M.S., Academy of Science of USSR*  
*Ph.D., Academy of Science of USSR*

Saafir, Rasheed (2014)  
Instructor, Administration of Justice  
*B.A., California State University of Fresno*  
*M.P.A., California State University of Dominguez Hills*

Salas, Angelita Figueroa (2011)  
TRIO STEM Coordinator/Counselor  
*A.A., Santa Ana College*  
*B.A., University of California, Berkeley*  
*M.S., San Francisco State University*  
*Ed.D., California State University, Long Beach*

Sanchez, Roxanna (2012)  
Counselor, DSPS program  
*B.A., California State University, Los Angeles*  
*M.A., California State University, Los Angeles*  
*M.S., California State University, Los Angeles*

Samaie, Parisa (2016)  
Assistant Professor  
*B. A. California State University, Long Beach*  
*M.L.I.S., University of California, Los Angeles*

Song, Rosa (2010)  
Instructor, Nursing  
*A.D.N., College of the Canyons*  
*B.A., University of Texas, Austin*  
*M.S.N., Mount Saint Mary's College*

Stewart, Robert (2008)  
Assistant Professor, Anatomy, Biology  
*B.S., California State University, Dominguez Hills*  
*M.S., California State University, Los Angeles*

Syed, Erum (2012)  
Associate Professor, Microbiology  
*B.S., Baqai Medical University*  
*M.S., Clemson University, SC*

Tadele, Gizaw, T. (2001)  
Instructor, Mathematics  
*B.S., Addis Ababa University*  
*M.S., Addis Ababa University*

Tatum, Heidi (2015)  
Assistant Professor Health Science  
*AA, Los Angeles Southwest College,*  
*B.S., Cal State Dominguez Hills*  
*M.S., Cal State Dominguez Hills*

Taylor, Katrina (2016)  
Assistant Professor, Communication Studies  
*B.S., Bradley University*  
*M.F.A., University of Washington*

Thompson, Lorna (2010)  
Instructor, Medical/Surgical Nursing  
*A.A., Los Angeles Southwest College*  
*B.S.N., Holy Names University*  
*M.S.N., Walden University*

Toure, Nouha (2000)  
Associate Professor, Business & Economics  
*A.A., Los Angeles Southwest College*  
*B.S., Woodbury University*  
*M.B.A., National University*

Toure, Pogban (2009)  
Instructor, Chemistry  
*B.S., University of Abidjan, Ivory Coast*  
*M.A., University of Abidjan, Ivory Coast*  
*M.S., Florida Institute of Technology*  
*Ph.D., University of California, Santa Barbara*

Tucker, Alexis J. (2005)  
Counselor, Instructor, Personal Development  
*A.A., Los Angeles Southwest College*  
*B.A., California State University, Dominguez Hills*  
*M.A., California State University, Dominguez Hills*

Turner-Odom, Sabrena (2005)  
Associate Professor, English  
*A.A., Los Angeles Southwest College*  
*B.A., University of Southern California*  
*M.A., University of California, Irvine*

Washington, Henry (1982)  
Head Football Coach, Physical Education  
*B.A., University of Redlands*  
*M.A., Brigham Young University, Utah*

Wider, Elizabeth (2016)  
Instructor, Nursing  
*A.D.N., East Los Angeles College*  
*B.A. Anthropology California State University, Los Angeles*  
*M.A. California State University, Northridge,*  
*M.S.N., California State University, Dominguez Hills*  
*EDD, University of Phoenix*

Williams, Michelle R. (2013)  
Counselor, EOPS/CARE Director, Assistant Professor  
*B.A. CSU Dominguez Hills*  
*M.S. University of LaVerne*

Wilson, Katrin R. (2015)  
Counselor, Articulation Officer  
*B.A., California State University, Long Beach*  
*M.S., Springfield College, M.A., California State University, Long Beach*  
*Ed.D., University of Southern California*

Wright, Kristine M. (2008)  
Instructor, Sociology  
*B.A., University of California, Los Angeles*  
*Ph.D., University of California, Irvine*

## CLASSIFIED STAFF

Akins, Shireen  
Admissions & Records Assistant

Barnes, Brian  
Custodian

Baquir-Streator, Ivey  
Senior Secretary

Barajas, Blanca  
SFP Director

Barron, Johnel  
Student Recruiter

Bell, Felicia  
Library Technician

Bebelle, Lynn  
Administrative Analyst, S.P.O.C.

Bell, Lorraine  
Senior Personnel Assistant

Berger, Rodnette  
Senior Secretary, (SFP)

Berry, James  
Custodian

Bingham, Wilda A.  
Athletic Trainer

Blevins, C'Artis  
Custodian

Bradley, James  
Custodian

Bradshaw, Brian  
Office Assistant

Buggage, C. Rhune'  
Student Services Aide

Burch, Vanessa  
Piano Accompanist

Campuzano, Ismael V.  
Carpenter

Carpenter, Kimberly  
Registrar

Carrilo, Julio  
Financial Aid Technician

Carter, Shauna  
Student Services Assistant

Casey, Kevin P.  
Library Technician

Chilin, Melvin  
SFP Specialist

Christopher, Damien  
Custodian Supervisor, A-Shift

Chu, Jackson  
Locksmith

Ciffuentes, Karen  
SFP Office Assistant

Collins, Joni  
Community Services Manager

Comegys, Darlene  
Administrative Secretary

Cortez, Maria  
Administrative Aide

Cosby, Sidney  
Program Specialist

Craig, Lisa  
Financial Aid Technician

Crown, Nicolas  
HVAC Technician

Dace, Stella  
Secretary

Daniel, Martha  
Custodian

Domio, Kenneth  
Custodian

Drake, Rochelle  
Custodian

Elfarissi, Kamal  
Life Science Lab Tech

Ferrer, James  
Computer Network Support  
Specialist

Flagg, James  
Reprographics Equipment  
Operator

Fox, Linda  
Senior Office Assistant

Francis, Edward  
Payroll Assistant

Franklin, Mickey  
Chemistry Lab Tech.

Garcia, Charles  
Library Technician

Gilmore, Dreshawn  
Senior Office Assistant

Go, Catherine  
Accounting Technician

Gomez, Domingo  
Library Technician

Gordon, Janet  
SFP Technician

Grayr, Karchikyan,  
Maintenance Assistant

Gupta, Vibha  
Manager College Information  
Systems

Guzman, Cholan Roxana  
SFP Technician

Hamilton, Keon  
Custodian

Hamilton, La Vonne  
Research Analyst

Harris, Michael  
Program Specialist

Hawes, Richards  
Custodian

Harvey, Howard  
Custodian

Hatley, John  
Custodian

Havlac, Frank  
Maintenance Assistant

Hollier, Blanche  
Facilities Assistant

Hunter, Mona  
Custodian

Ignant, Ronnie  
Custodian

Jones, Linda  
SFP Office Assistant

Jones, Philip  
Gardner

Jordan, Debbie  
SFP Technician

Kuzmink, Lubov  
Supervisor

Le, Frank  
Gardener

Livingston, Kim  
Custodian

Madriz, Martha C.  
SFP Program Technician

Mah, Allison  
Director

Manyweather, Laura  
Learning Outcomes Coordinator



Martinez, Aracely  
Senior Office Assistant

Mayo, Gary  
Plumber

Mayorga, Erica  
SFP Director

Mithitryan, Nune  
Accounting Assistant

Mix, Robert  
Custodian Supervisor, B-Shift

Morgado, Osmin  
Instructional Asst. Info. Tech.

Neal, Jamaal  
Custodian

Nelson, Sinchell  
Senior Secretary

Olvera, Victor  
Gardener

Owens, Yvonne  
Instructional Assistant

Ozan, Christzann  
Custodian

Paniagua, Oscar  
Admissions & Records Assistant

Parker, Christin  
Community Services Assistant III

Peralta, Luciana  
Admissions & Records Technician

Piernas, Leilani  
Admissions & Records Assistant

Phillips, Gary  
Custodian

Prompongsatorn, Voragit  
Maintenance Assistant

Quach, John  
Instructional Assistant Info. Tech

Reed, Stanley  
Maintenance Assistant

Rice, Maria  
Financial Aid Technician

Roberts, Ronald  
Custodian

Robertson, Jerome  
SFP Technician

Robinson, Brian  
Stock Control Assistant

Romero, Mario  
SFP Technician

Rodriguez, Ernesto  
Financial Aid Technician

Rosario, Bessie  
Cashier

Silva, Ricardo  
Electrician

Smith, Robert  
Custodian

Stewart, Chauncine  
Executive Assistant

Solval, Emilia  
Special Services Assistant

Tatum, Ronald  
Stock Control Aide

Taubr, Alex  
Instructional Media Assistant

Tello, Jose L.  
Painter

Tippens, Traci  
Senior Secretary

Toussant-Jackson, Anika  
Learning Outcomes Coordinator

Torres, Angela  
Admissions & Records Assistant

Tucker, Yvette  
Veterans Representative

Turner, Rickey  
Custodian

Vasquez, Ray  
Custodian

Venable, Aynjellia  
Secretary

Walker, Cassaundra  
Academic Scheduling Specialist

Ward, Deborah  
Administrative Assistant

Ward, Nicholas  
Accounting Technician

Warren, Shakeeba  
SFP Technician

Williams, Charles  
Custodian

Williams, John  
Pool Tech

Williams, Mark  
Custodian

Williams, Sheryl  
Financial Aid Technician

Xie, Aubrey  
Instructional Assistant

Zamora, Genaro  
Gardener

Zamora, Robert  
General Foreman

Zhang, Jessica  
Accountant

Zhu, Jason  
Senior Accountant

## FACULTY EMERITI

Adler, A. Jay 1994-2013 Professor, English	Frisby, James R.; 1977-1995; Professor of English	Love, Clara; 1989-1999; Professor of Registered Nursing
Arnold, Margaret L.; 1976-1995; Professor of English	Gabriel, Doris H.; 1968-1976; Associate Professor of Business	McAfee, Margaret B.; 1969-1989; Professor of Art
Avins, Alfred; 1968-1983; Professor of Business	Geoghagen, Augustine; 1973-1992; Professor of Counseling	McClelland, Evelyn; 1981-1991; Professor of Nursing
Blechman, Marcella; 1971-1980; Professor of Office Administration	Green, Gaston; 1998-2003; Director of Upward Bound	Mackey, Ralph T., Sr.; 1983-1989; Instructor of Engineering
Bost, Joyce C.; 1980-2007; Professor of Nursing	Griffith, Hortensia; 1991-2004; Director of CARE Program, Associate Professor, Counselor	Maddox, Kerman; 1990-2005; Professor of Political Science
Butler, Ella; 1976-1995; Professor of Office Administration	Gustafson, Adelle; 1968-1983; Professor of Office Administration	Maddox, Marion; 1969-1983; Professor of English
Carlan, Audrey M.; 1968-1989; Professor of Mathematics	Harris, Lola Hanson; 1980-1995; Professor of Developmental Communications	Marsh, L. Benson; 1969-1985; Professor of Prosthetics and Orthotics, Instructor in Health Education
Chilk, Tillie; 1971-1980; Associate Professor of Nursing	Herwig, Margaret; 1968-1983; Professor of Physical Education	Matthews, Jacquelyn Y.; 1978-2004; Professor of Computer Applications and Office Technology
Cliff, Kathi 1978-2014 Director, Child Development Center, Professor, Child Development	Huber, Charlotte; 1969-1975; Professor of English and Journalism	McCollum, Patricia; 1977-2004; Professor of Library Sciences
Cobbs, Herbert; 1989-2003; Instructor, Library Science	Itow, Pauline; 1980-2010); Professor of Child Development	Moore, Bessie; 1969-1983; Professor of Nursing
Colbert, Toni; 1971 -2004; Professor of Sociology	Jackson, Roland; 1976-1995; Professor of Music	Morton, Katherine; 1969-1979; Associate Professor of Speech
Cook, Robert; 1967-1982; Coordinator of Institutional Research	Jacobson, Marvin; 1968-2000; Professor, Geology	Mulholland, William; 1967-1977; Mathematics Instructor
Cooper, Granville	Johnson, Avery; 1998-2003; Counselor	Nolcox, Noble; 1990-2007; Professor of English
Davis, Donovan; 1970-2003; Professor of Psychology and Anthropology	Jordan, Walter; 1980-2003; Professor of Physics	Palmer, Earnestine; Counselor
Doyle, William; 1969-1991; Professor of History	Keeney, Phyllis I.; 1967-1995; Professor of Physical Education	Pang, Henry I.; 1976-1995; Associate Professor of Mathematics
Dright, Lloyce; 1968-1983; Professor of Nursing, Counselor	Kier, Ralph; 1969-2000 Professor of Accounting and Business	Panjabi, Hari P.; 1976-1995; Professor of Engineering
Eckersley, Darrell; 1971-2004; Professor of English	Landesman, Herbert; 1969-1995; Professor of Chemistry	Pape, Geraldine; 1969-1976; Associate Professor of English
Engberg, Charles J.; 1971-1989; Professor of Mathematics	Landsdowne, Noblesse A.; 1969-1978; Associate Professor of Zoology	Perez, Rose; 1969-1982; Professor of Library Media
Fischer, Donald; 1969-1978; Professor of English	Lewis, Pat; 1977-2012 Professor Communication Studies	Perkins, Helen E.; 1968-1984; Professor of Nursing
Fobi, Charlene; 1976-; Professor of Nursing	Levine, Ettabelle N; 1968-1983; Professor of Business	Phifer, Elaine E.; 1976-; Professor of Nursing
Forge, Liz; 1976-1995; Director of Child Care Center	Lopez, Ronald W.; 1990-2007; Professor of History	Rhodes, Anthonetta (Toni); 1978-2011; Professor of Child Development
Frank, Lee; 1968-1989; Professor of English	Lott, Vivian; 1998-2006; Professor of Learning Skills and Developmental Communications	Riggs, Jan; 1976-2007; Associate Professor, Physical Education
Friedland, Lila; 1971-2000; Professor of Registered Nursing		



Robinson, Alyce; 1969-1989; Professor of Library Science

Rubenstein, Arthur; 1970-1985; Professor of History

Ryner, Margaret; 1969-1985; Professor of Nursing

Sapin, Dan P.; 1969-1995; Professor of Psychology

Schauer, David; 1971-1998; Professor of Mathematics

Scott, Roselyn; 1968-1989; Professor of Family and Consumer Studies

Seeman, Helene; 1996-2005; Associate Professor of Nursing

Strain, Sibyl M.; 1967-1984; Professor of Psychology

(Studer) Stafford, Merrilee; 1967-1983; Professor of Speech

Sweeney, Cecily P.; 1991-2005; Professor of Humanities and Music

Tarr, Betty R.; 1968-1983; Professor of Chemistry

Thomas-Robertson, Earnestine

Thompson, James C.; 1971-1980; Instructor Physical Education

Twine, Everett; 1972-1983; Professor of History

Verity, Suebelle S.; 1968-1995; Professor of Biology

Wallace, Don; Humanities

Wallace, Ruby; 1977-2004; Professor, Developmental Communications & English

Ward, Ulysses V.; 1968-1989; Professor of Mathematics

Ware, Mary; 1969-2000; Professor of English

Way, Lee; 1989-2007; Professor of Mathematics

Williams, Elizabeth; 1970-1983; Professor of Music

Williams, Jo Ann; 1998-2006; Professor of Nursing

Williams, Russell B.; 1968-1999; Professor of Biology

Winters, Manque; 1975-1999; Counseling

Yoshida, Glenn; 1977-2011

Zager, Evelyn L.; 1968-1978; Professor of Family and Consumer

## COURSE DESCRIPTIONS

Courses that meet the major requirements of the educational programs listed in this catalog may be applied towards graduation requirements for the Associate Degree. All transfer courses may be applied to the Associate Degree. One of the following designations may appear after the noted units, indicating that the course is transferable and will be accepted towards meeting the 60 unit admission requirement at either the University of California or the California State Colleges and Universities.

- UC = Transferable to the University of California
- CSU = Transferable to the California State College and Universities

Most Southwest classes are for-credit courses. Some courses which are offered for college credit, but which cannot be applied toward graduation requirements for the Associate Degree, are designated:

- NDA = Non-degree applicable
- NC = Non-credit

The student should examine carefully the course descriptions, prerequisites, and number of units required, before enrolling in a given subject.

Most courses offered at LASC are web-enhanced courses, and students taking courses at LASC will be expected to utilize online resources/computer technology. Course classifications and definitions currently are:

**Web-Enhanced:** Is a regular class that utilizes online content for course content and/or activities. Classes must meet as scheduled on campus.

**Hybrid:** If one or more class sessions (up to 50%) is replaced with online content and/or activities, it is considered a Hybrid course. A Hybrid course can utilize features of the Learning Management System, such as Course Documents, Discussion Boards, Virtual Classrooms, Groups, Assignments, External Links, Digital Drop Boxes and Grade Books, etc. The course can be offered during regularly scheduled class times or with Online components that replace some of the regularly scheduled class meetings. Notice of face-to-face class sessions will be given by instructors in their syllabus.

**Online:** An Online course is offered 100% online. Students cannot be required to attend a physical classroom when participating in an online course. An online course shall utilize features of the Learning Management System, such as Course Documents, Discussion Boards, Virtual Classrooms, Groups, Assignments, External Links, Digital Drop Boxes and Grade Books, etc. All course instruction, materials, assignments, and discussions are posted and done online. Online courses require the student and instructor the same amount of course work and hours outside of the classroom as traditional courses; they are offered in a more flexible and independent environment.

In the parentheses adjacent to each course title is a number indicating the number of units of credit offered.

Where this is followed by the symbol RPT and a number, the course may be REPEATED FOR CREDIT as many times as indicated by the number.





## ACADEMIC PREPARATION (NONCREDIT)

### 05CE Language Arts: Reading Non-Fiction (0) NC

Lecture: 3 hours

This course reviews the most common writing patterns that are generally found in college textbooks. The organization of ideas is studied in conjunction with the strategies with which the reader can improve reading comprehension in various subject areas using college textbooks.

## ACCOUNTING

### 1 Introductory Accounting I (5) UC:CSU

Recommended: Business 38, English 101, Math 115

Lecture: 5 hours

This is the study of accounting as an information system, examining why it is important and how it is used by investors, creditors, and others to make decisions. The course covers the accounting information system, including recording and reporting of business transactions with a focus on the accounting cycle, the application of generally accepted accounting principles, the financial statements, and statement analysis. Includes issues relating to asset, liability, and equity valuation, revenue and expense recognition, cash flow, internal controls, and ethics.

Note: Accounting 21 (3) and Accounting 22 (3), when taken together, are equivalent to Accounting 1 (5).

### 2 Introductory Accounting II (5) UC:CSU

Prerequisite: Accounting 1 or 22

Lecture: 5 hours

This is the study of how managers use accounting information in decision-making, planning, directing operations and controlling. Focuses on cost terms and concepts, cost behavior, cost structure and cost-volume-profit analysis. Includes issues relating to cost systems, cost control, profit planning, and performance analysis in manufacturing and service environments.

### 15 Tax Accounting I (3) CSU

Prerequisite: Accounting 1

Lecture: 3 hours

This course offers a study of Federal and California State Income Taxes as they apply to individuals and sole proprietorships and an analysis of laws, consideration of appropriate accounting procedures, and preparation of federal and state tax returns.

### 17 Payroll Accounting (2)

Prerequisite: Accounting 1 or Accounting 21 and Accounting 22

This course includes methods and procedures of compiling the payroll records and preparation of payroll tax returns as required by State and Federal laws. Included are State and Federal unemployment reports, Federal Social Security, and Workers Compensation reports.

### 21 Bookkeeping and Accounting I (3) UC:CSU

Recommended: Business 38

Lecture: 3 hours

This course introduces the fundamentals of double-entry bookkeeping, preparation of the trial balance, adjusting journal entries, worksheets and simple financial statements, use of controlling accounts, and an introduction to merchandising. This course is for the student who wishes a slower pace than Introductory Accounting or needs only a basic understanding of the accounting cycle.

Note: Accounting 21 (3), when taken with Accounting 22 (3), is equivalent to Accounting 1 (5).

### 22 Bookkeeping and Accounting II (3) UC:CSU

Prerequisite: Accounting 21

Lecture: 3 hours

This course is a continuation of Accounting 21 and includes the control of cash and preparation of bank reconciliation statements, accounting for receivables and payables, bad debts, inventories, fixed assets, depreciation, and an introduction to accounting for partnerships.

Note: Accounting 22 (3), when taken with Accounting 21 (3), is equivalent to Accounting 1 (5).

### 25 Automated Accounting Methods and Procedures (3) CSU

Prerequisite: Accounting 1 or 22

Lecture: 3 hours

This course uses computer software to prepare accounting transactions and financial statements. Spreadsheet software will be used as well. Instruction is provided in the following areas: general ledger, depreciation, accounts receivable, accounts payable, and payroll. Real world applications will be stressed throughout the course. This course uses QuickBooks Pro and Excel software. At the end of the course students will be prepared for and be offered the opportunity to become a Certified QuickBooks user.

## ADMINISTRATION OF JUSTICE

### 1 Introduction to Administration of Justice (3) UC:CSU

CSUGE Area D8

Lecture: 3 hours

This course discusses the philosophy and history of law enforcement; provides an overview of crime and police problems; organization and jurisdiction of local, state, and federal law enforcement agencies; and surveys professional career opportunities and qualifications required for entry into a career in Administration of Justice.

### 2 Concepts of Criminal Law (3) UC:CSU

CSUGE Area D8

Recommended: Administration of Justice 1

Lecture: 3 hours

This course provides an overview of the historical and philosophical foundations of law, and covers the classifications, structure, definitions, and the most frequently cited sections of penal codes and other criminal statutes.

### 3 Legal Aspects of Evidence (3) CSU

Prerequisite: Administration of Justice 1

Lecture: 3 hours

This course covers the origin, development, philosophy and constitutional basis of evidence; constitutional and procedural considerations affecting arrest, search and seizure; kinds and degrees of evidence and rules governing admissibility; and judicial decisions interpreting individual rights and case studies.

### 4 Principles and Procedures of the Justice System (3) CSU

Prerequisite: Administration of Justice 1

Lecture: 3 hours

This course covers a review of court systems; procedures

from incident to final disposition including policing, prosecution, court proceedings; the correctional process; and principles of constitutional, federal, state and civil laws as they apply to and affect law enforcement.

### **5 Criminal Investigation (3) CSU**

*Prerequisite: Administration of Justice 1*

*Recommended: Administration of Justice 3*

*Lecture: 3 hours*

This course covers the fundamentals of investigation, crime scene search and recording, collection and preservation of physical evidence, scientific aids, modus operandi, sources of information, interviews and interrogation, follow-up and case preparation.

### **6 Patrol Procedures (3) CSU**

*Recommended: Administration of Justice 1*

*Lecture: 3 hours*

This course is a study of requirements, techniques and methods of conducting vehicle patrol. Basic tactics as well as procedures will be analyzed. Deployment formulas will be discussed along with research studies on the handling of civil domestic disturbances and other community crime incidents.

### **7 Traffic Control (3) CSU**

*Lecture: 3 hours*

The student in this course will study traffic law enforcement, regulation and control, fundamentals of traffic accident investigation, and the California Vehicle Code.

### **8 Juvenile Procedures (3) CSU**

*Lecture: 3 hours*

This course covers the nature and extent of juvenile delinquency, juvenile court philosophy and law, the role of law enforcement in the investigation, prevention and control of delinquency, theoretical approaches to delinquency causation, and prevention programs.

### **14 Report Writing for Peace Officers (3) CSU**

*Recommended: Administration of Justice 1*

*Lecture: 3 hours*

This course presents various types of technical writing commonly used in police reports, the appropriateness of different styles in different contexts, the conceptualizations of the material, and the use of these reports by analytical officers in police agencies. Aspects of standard report writing are included.

### **16 Recruitment Selection Process (3) CSU**

*Lecture: 3 hours*

This course provides an in-depth coverage of the legal selection process designed to assist students with employment in a law enforcement agency. Written exam techniques, oral exam techniques and the agility exam are covered. The background investigation, psychology test and medical exam are explained. Practical ways to assist the candidate through the Academy are also included.

### **41 Officer Safety (3) CSU**

*Lecture: 3 hours*

The study of techniques of protection against persons armed with dangerous and deadly weapons. Students examine the moral aspects, legal provisions, safety precautions and restrictions covering the use of firearms and other weapons.

### **49 Narcotics and Vice Control (3) CSU**

*Lecture: 3 hours*

This course presents the covert criminal activities of organized crime within the community and the impact that these activities have on the social structure. This course discusses the history of illegal drugs and analyzes how law enforcement has attempted to control the widespread use of illegal drugs and the criminal enterprises that dominate the narcotics trade. Vice operations and the criminal enterprises that control these activities are also examined in depth.

### **62 Fingerprint Classification (3) CSU**

*Recommended: Administration of Justice 1*

*Lecture: 3 hours*

This is a practical course which covers the technical terminology of fingerprinting, pattern interpretation, classification of fingerprints, the taking of fingerprints, searching and filing procedures, and laboratory work in the classroom.

### **63 Introduction to Criminology (3) UC:CSU**

*IGETC Area 4J*

*CSUGE Area D0*

*Recommended: Administration of Justice 1*

*Lecture: 3 hours*

This course is an introduction to the theoretical and philosophical concept of criminology; the nature and extent of crime in America; the roles of the organization in the Administration of Justice; prevailing theories of crime causation; and the judicial, correction, and rehabilitation processes.

### **67 Community Relations I (3) UC:CSU**

*Lecture: 3 hours*

This course explores the interrelationships and role expectations among the various Administration of Justice practitioners, agencies, and the public. Principal emphasis will be placed upon the professional image of the system of Justice Administration and the development of positive relationships between members of the system and the public.

### **73 Law and Minority Groups (3) CSU**

*Lecture: 3 hours*

This course examines the growing crises of race, ethnicity, gender and discrimination within the American Justice System. Myths and realities about crime and minorities are analyzed. Racism and inequities within the legal structures including court trials, corrections and the death penalty are discussed. Changes in criminal justice administration advocated by minority groups are reviewed.

### **75 Introduction to Corrections (3) CSU**

*Recommended: Administration of Justice 1*

*Lecture: 3 hours*

This is a basic course dealing with the nature of correctional work; aims and objectives of correctional administration; probation and correctional practices; skills, knowledge and attitudes required for employment in this field; and types of institutions, services and career opportunities.

### **83 Introduction to Security (3) CSU**

*Prerequisite: Administration of Justice 3*

*Recommended: Administration of Justice 1*

*Lecture: 3 hours*

This course is a basic course dealing with the historical, philosophical, and legal background of the security services function; interrelationships with allied agencies and individuals; the role of security in contemporary society; and provides a survey of career opportunities and required qualifications.

**180 Introduction to Forensics (3) CSU***Prerequisite: Administration of Justice 1**Lecture: 3 hours*

This course concentrates on crime scene evidence processing; to include: detection, inspection, collection, preservation, and interpretation. The basics of Forensic Science will be covered also, including: serology (DNA), trace evidence, crime scene photography, firearms analysis, and fingerprint analysis. Insight into crime lab procedures will be provided through 'hands-on' applications

**310 Field Work I (3) CSU***Lecture: 3 hours*

This is a service learning class. Students will participate, under supervision, in a law enforcement or correctional facility such as a probation/parole field office, jail, detention center, juvenile camp, juvenile institution, or a similar agency. Students must meet the minimum entry-level requirements of the sponsoring agency and will be livescanned, take an oath, and TB test. The class meets once per week for one hour, and then the students will have volunteer assignments for a minimum of five hours per week with a sponsoring agency

**AFRICAN AMERICAN STUDIES****2 The African American in Contemporary Urban Society (3) UC:CSU***CSUGE Area D3, D8**Lecture: 3 hours*

A survey of the urbanization of the African American with emphasis on contemporary issues, public policy solutions, civil rights, and equality of opportunity. Issues include education, housing, economics (welfare, poverty, and employment), politics, justice and law enforcement, urban and community development, and family.

**7 Black Americans and the Political System (3) UC:CSU***CSUGE Area D3, D8**Lecture: 3 hours*

Students analyze the relationship of minority groups to American Politics with emphasis on African Americans in the political system. This course gives an in-depth study of the distribution of political power at the Federal and State levels, African American political thought, ranging from early 18th and 19th emigrationist sentiments to the nationalist exhortations of contemporary African American culture, including African American feminist and socialist thought.

**AMERICAN SIGN LANGUAGE****1 American Sign Language I (4) UC:CSU***IGETC Area 6A**CSUGE Area C2**Lecture: 4 hours*

This is an introductory course designed to develop basic conversational skills using the manual alphabet and American Sign Language. It is planned to assist in communicating with deaf individuals and have a better understanding of Deaf Culture. This course develops basic vocabulary and grammar of American Sign Language. Its emphasis is placed on comprehension skills and vital aspects of the Deaf Culture and community.

*Note: Corresponds to the first two years of high school study.*

**2 American Sign Language II (4) UC:CSU***IGETC Area 6A**CSUGE Area C2**Prerequisite: American Sign Language I**Recommended: English 21**Lecture: 4 hours*

This is an intermediate course designed to develop conversational skills using the manual alphabet and American Sign Language. It is planned to assist in communicating with deaf individuals and have a better understanding of Deaf Culture. This course continues to develop vocabulary and grammar of American Sign Language. Its emphasis is placed on comprehension skills and vital aspects of the Deaf Culture and community.

**3 Advanced American Sign Language III (4) UC:CSU***IGETC Area 3B; 6A**Prerequisite: American Sign Language 2**Lecture: 4 hours*

This course provides in-depth training in receptive and expressive sign language skills with emphasis upon fluency, precision, and vocabulary building.

**ANATOMY****1 Introduction to Human Anatomy (4)****UC:CSU***IGETC Area 5B; 5C**CSUGE Area B2, B3**Lecture: 3 hours; Lab: 3 hours*

Upon completion of this course, the student will be able to identify and describe the major structural characteristics of the cells, tissues, and organs comprising the following systems of the human body: integumentary, skeletal, muscular, nervous, cardiovascular, lymphatic, respiratory, digestive, urinary, reproductive, and endocrine systems. Using anatomical terminology, the student will also be able to describe the major locations of the major tissues and organs of these systems.

*Note: This course, when taken with Physiology 1, is equivalent to Biology 20.*

**ANTHROPOLOGY****101 Human Biological Evolution (3)****UC:CSU***IGETC Area 5B**CSUGE Area B2**Lecture: 3 hours*

This course is an introduction to the field of biological anthropology. Topics covered include genetic inheritance, the mechanisms of evolution, the biology and behavior of living primates, the history of human evolution as seen in the fossil record, and modern human biological variation.

**102 Human Ways of Life: Cultural Anthropology (3) UC:CSU***IGETC Area 4A**CSUGE Area D1**Lecture: 3 hours*

This course is an introduction to the field of sociocultural anthropology and examines the diversity of human life around the world. Topics covered include the "culture" concept and ethnography; language, family, gender, and religion; social stratification and inequality; economic and political systems; cultural change and contemporary globalization.

### 103 Archeology: Reconstructing the Human Past (3) UC:CSU

IGETC Area 4A  
 CSUGE Area D1  
 Lecture: 3 Hours

This course is an introduction to the concepts, theories, and methods of anthropological archaeology as well as a review of significant data and models that contribute to our knowledge of the human past. Topics covered include the history and interdisciplinary nature of archaeological research; dating techniques; methods of survey, excavation, analysis, and interpretation; cultural resource management; professional ethics; and selected cultural sequences.

### 104 Human Language and Communication (3) UC:CSU

IGETC Area 3B, 4A  
 CSUGE Area C2, D1  
 Lecture: 3 hours

This course is an introduction to the anthropological study of language. It surveys three core areas of linguistic anthropology: structural linguistics (phonetics, phonology, morphology, syntax, and the biological basis of language); historical linguistics (origins of language, language change, and dialect diversity); and sociocultural linguistics (the role of the cultural context in language acquisition, language and power, and language conservation and loss).

### 111 Laboratory in Human Biological Evolution (2) CSU

CSUGE Area B3  
 Corequisite: Anthropology 101  
 Lecture: 1 hour, Lab: 2 hours

This laboratory course introduces students to the scientific method and to the techniques and procedures used in biological anthropology. Hands-on laboratory exercises explore selected topics in human evolution that may include: genetics; taxonomy and classification; geological time and fossilization; human and non-human primate anatomy and behavior; the hominin fossil record; and human variation. Students must complete Anthropology 101 or be currently enrolled.

### 121 Religion, Magic & Witchcraft (3) CSU

Recommended: English 28  
 Lecture: 3 hours

This course is an introduction to the anthropological study of religion and examines the way religion is lived and practiced in diverse cultures. Topics covered include mythology, symbolism, ritual, magic, and witchcraft; the course examines the role of religion in human experiences of sickness and death and explores contemporary issues of religious change, conflict, and violence.

### 132 Native People of North America (3) UC:CSU

Lecture: 3 hours

This course examines the indigenous inhabitants of North America from prehistoric times until the present. Archaeology, cultural ecology, linguistics, ethno-history, and ethnography provide evidence for the unique cultures which have flourished in this region of the continent since the end of the Pleistocene. Contemporary issues in Native American studies, such as the ownership and repatriation of archaeological remains and Indian gaming, will also be explored.

### 133 Peoples and Cultures of Africa (3) UC:CSU

IGETC Area 4A  
 CSUGE Area D1  
 Lecture: 3 hours

This course is an ethnographic survey of the peoples and cultures of the African continent. It will examine classic anthropological topics such as gender, religion, economic and political systems. In addition, the course will focus on pre-colonial African societies, the causes and consequences of the trans-Atlantic slave trade, European colonialism, and post-colonial development efforts. Central contemporary issues such as globalization, urbanization, conflict, and health will be examined.

## ART

### 101 Survey of Art History I (3) UC:CSU

IGETC Area 3A  
 CSUGE Area C1  
 Recommended: English 28  
 Lecture: 3 hours

A study is made of the historical development of Western art from the prehistoric through the Gothic periods as well as from selected Non-Western cultures. Attention is given to an analysis of the work of each period and culture.

### 102 Survey of Art History II (3) UC:CSU

IGETC Area 3A  
 CSUGE Area C1  
 Recommended: English 28  
 Lecture: 3 hours

A study is made of the historical development of Western art from the Renaissance through the 21st Century with attention given to an analysis of the works of each period.

### 103 Art Appreciation I (3) UC:CSU

IGETC Area 3A  
 CSUGE Area C1  
 Recommended: English 28  
 Lecture: 3 hours.

This is a cultural course designed to acquaint the general student with the art products of our civilization and to provide a basis and an understanding of the fundamental art principles expressed in both the useful and the fine arts. Emphasis is placed on understanding the creative process and developing a basis for critical judgment (prehistoric through Gothic works).

### 104 Art Appreciation II (3) UC:CSU

IGETC Area 3A  
 CSUGE Area C1  
 Recommended: English 28  
 Lecture: 3 hours.

This is a basic course in art appreciation in which the student will experience visual art through the study of selected artists and artwork. Exercises in visual perception are stressed; individual research on the art of selected cultures is conducted. (Renaissance through 21st Century)

### 201 Drawing I (3) UC:CSU

CSUGE Area C1  
 Lecture: 2 hours; Lab: 2 hours

This course provides an introduction to drawing theory and practice. Great works of the human imagination will be explored and studied in relation to drawing techniques. Uses of line and space systems (including linear perspective and light logic) are developed and employed to define three dimensional space.

**202 Drawing II (3) UC:CSU***Prerequisite: Art 201**Lecture: 2 hours; Lab: 2 hours*

This course is a continuation of Art 201. Emphasis will be placed on the application and refinement of space systems (i.e., light logic and linear perspective) and mastery of advanced compositional solutions. Approaches to subject matter, including Cubism and Surrealism, will be examined. Media, including pen and ink, and pastels, will be explored.

**204 Life Drawing I (3) UC:CSU***Prerequisite: Art 201*

Introduction to drawing the human figure from observation using a wide variety of drawing media and techniques. Topics include an introduction to human anatomy and the historical and contemporary roles of figure drawing in the visual arts. Students in this course will learn both descriptive and interpretive approaches to drawing the figure.

**213 Color Theory (3) UC:CSU***Prerequisite: Art 501**Lecture: 2 hours; Lab: 2 hours*

This course examines Color Dynamics. The topics considered include form and value, harmony and spatial effects. The major theorists introduced include Goethe, Itten and Albers. In addition to the traditional 12-part color wheel, digital color principles are also examined.

**300 Introduction to Painting (3) UC:CSU***CSUGE Area C1**Lecture: 2 hours; Lab: 2 hours*

This is an introductory course in painting covering the basic skills and techniques in oil, acrylic, and watercolor. Emphasis is on principles relating to composition and color.

**307 Oil Painting I (3) UC:CSU***Lecture: 1 hour; Lab: 5 hours*

This is an introductory course in oil painting and covers the basic skills and techniques. Problems are presented which are important to the understanding of painting as a means of expressing formal concepts.

**308 Oil Painting II (3) UC:CSU***Prerequisite: Art 307**Lecture: 1 hour; Lab: 5 hours*

This course is a continuation of Art 307, Oil Painting I. Emphasis will be on individually conceived projects in oil painting.

**309 Oil Painting III (3) UC:CSU***Prerequisite: Art 308**Lecture: 1 hour; Lab: 5 hours*

This course is a continuation of Art 308, Oil Painting II. Emphasis will be on individually conceived projects in oil painting and the preparation of a portfolio.

**501 Beginning Two-Dimensional Design (3) UC:CSU***CSUGE Area C1**Lecture: 2 hours; Lab: 2 hours*

This course introduces the fundamentals of two-dimensional composition. A study is made of line, shape, value, texture, color, and the pictorial organization of these and other elements and principles of Art.

**502 Beginning Three-Dimensional Design****(3) UC:CSU***Lecture: 2 Hours; Lab: 2 Hours*

This class introduces the principles of three-dimensional design utilizing a variety of techniques and materials. Exercises will be given in geometric and biomorphic shapes. Various mediums and fabrication techniques will be explored, including foam board, wood, found objects, wire, modeling clay and plaster. Design theory is integrated with historical and cultural foundation. Students develop analytical visual skills and critical awareness.

**ART HISTORY****126 Introduction to Modern Art (3) UC:CSU***CSUGE Area C1**Recommended: English 101**Lecture: 3 hours*

This course provides an overview of art and architecture from the Western modern period of the 19th and 20th centuries.

**130 Survey of Asian Art History (3) CSU***CSUGE Area C1**Recommended: English 101**Lecture: 3 hours*

This course provides a select overview of art and architecture from India, Southeast Asia, China, Korea, and Japan from pre-history to modern times.

**140 Survey of Arts of Africa, Oceania, and Ancient America (3) CSU***CSUGE Area C1**Recommended: English 101**Lecture: 3 hours*

Survey of visual culture within select regions in Africa, Oceania, and indigenous North America.

**ASTRONOMY****1 Elementary Astronomy (3) UC:CSU***CSUGE Area B1**Lecture: 3 hours*

A fascinating look into the general principles and the fundamental facts of astronomy. This introductory course is designed for the non-technical student. Topics covered include the history and science of astronomy, the solar system, our sun, stars, galaxies and cosmology. No college math preparation is needed. If a student wishes to transfer this as a lab science course, the student must also complete Astronomy 5.

**5 Fundamentals of Astronomy Laboratory (1) UC:CSU***CSUGE Area B3**Lab: 3 hours*

This course provides the laboratory work to accompany or follow Astronomy 1. Astronomy 5 laboratory course offers an introductory presentation of the methods and techniques used by astronomers to determine the nature of the universe. This course uses some very basic mathematics, and can be taken by non-science and/or science majors. When taken together with either Astronomy 001, a student's 'science with a lab' transfer and graduation requirement is met. Topics include, work with celestial sphere, sky charts, optical bench, telescopes, spectrometers, and photometer. The course requires field trips for evening observations.

## BASIC SKILLS (BSICSKL) (NONCREDIT)

### 002CE Basic English Skills (0)

Lecture: 3 hours

This course is for students with limited knowledge of standard English structure. Emphasis is on basic grammatical forms and functions. Vocabulary development is included for increased expression, especially in speaking and writing.

### 023CE College and Scholastic Assessment Preparation (0)

Lecture: 4 hours

This course is designed to prepare students to be assessed and/or to take standardized or proficiency exams in the content areas of Math and English. This course provides an overview and review of these areas and is not intended to provide in-depth instruction.

### 028CE Basic Skills Pre-Algebra (0)

Lecture: 3 hours

This noncredit course is designed to prepare students for transition from arithmetic to algebra. Concepts, computational skills and problem solving skills are introduced and practiced to build mastery and proficiency.

### 35CE Basic Math Skills (0)

Lecture: 3 hours

This course is designed to strengthen basic math skills. Topics include properties, rounding, estimating, comparing, converting, and computing whole numbers, fractions and decimals.

### 83CE GED Preparation: Literature and the Arts (0)

Lecture: 3 hours

This course is designed to prepare students for the General Educational Development (GED): Literature and the Arts Test or other high school equivalency exams or other high school equivalency exams (HiSET, TASC). Course content includes critical thinking skills- reading comprehension skills, interpreting graphs, analyzing literature and the arts including tone and style/prose fiction, interpreting poetry, drama, plays, non-fiction and commentaries.

### 84CE GED Preparation: Mathematics (0)

Lecture: 3 hours

This course is designed to prepare students for the General Educational Development (GED): Mathematics Test or other high school equivalency exams (HiSET, TASC). Course content includes arithmetic, the metric system, algebra, geometry, statistics, and probability problems. Depending upon the diagnostic assessment, students will be directed to an appropriate plan of study.

### 85CE GED Preparation: Science (0)

Lecture: 3 hours

This course is designed to prepare students to pass the General Educational Development (GED): Science Test or other high school equivalency exams (HiSET, TASC). Course content includes biology, earth science, astronomy, geology, meteorology, chemistry, and physics.

### 86CE GED Preparation: Social Studies (0)

Lecture: 3 hours

This course is designed to assist students prepare for the Social Studies component of the General Education

Development (GED) examination or other high school equivalency exams (HiSET, TASC). Course content includes the five basic social studies content areas: United States history, civics and government, economics, and geography.

### 87CE GED Preparation: Writing Skills (0)

Lecture: 3 hours

This course is designed to prepare students for the Language, Writing Skills component of the General Educational Development (GED) examination or other high school equivalency exams (HiSET, TASC). Course content includes sentence structure, English usage, mechanics, and writing 5-paragraph essays.

## BIOLOGY

### 3 Introduction to Biology (4) UC:CSU

IGETC Area 5B, 5C

CSUGE Area B2, B3

Lecture: 3 hours; Lab: 3 hours

In this course the student will identify and describe the basic characteristics of life through the concepts of cell structure and function, energy interrelationships, information transfer and duplication, reproduction and development, evolution, ecology, and adaptation. The student will also be able to apply the concepts to related laboratory exercises, current and historical literature, and discussions of the effect of humans on the environment.

### 5 Introduction to Human Biology (4)

UC:CSU

IGETC Area 5B, 5C

CSUGE Area B2, B3

Lecture: 3 hours; Lab: 3 hours

The course includes basic biological principles as they apply to humans. The course will provide a foundation for advanced courses in Human Anatomy, Physiology and Microbiology. Topics will include human structure, function, heredity, development, evolution, ecology, disease, and bio-ethics.

### 6 General Biology I (5) UC:CSU

IGETC Area 5B, 5C

CSUGE Area B2, B3

Prerequisite: Math 125

Lecture: 3 hours; Lab: 6 hours

In this course the student learns to identify and describe basic physiological processes of living things, basic cellular and subcellular organization, and morphology and diversity of major plant phyla. The student will also learn to apply the principles of genetics to the analysis of natural selection, population studies, and speciation.

### 7 General Biology II (5) UC:CSU

IGETC Area 5B, 5C

CSUGE Area B2, B3

Prerequisite: Math 125

Lecture: 3 hours; Lab: 6 hours

In this course the student learns to identify and describe the comparative morphology of the major animal phyla; morphology and physiology of the major organ systems; and the reproduction, growth, and development of organisms. The student will also learn to apply the principles of ecology, behavior, and adaptation to the analysis of plant and animal ecosystems.

### 9 Man and His Environment: Biological Processes (3) CSU



*Lecture: 3 hours*

This course utilizes basic biological concepts in an interdisciplinary approach to address environmental challenges. Topics addressed may include ecosystem characteristics and functions, population dynamics, energy and material resource use, and pollution and alternative energy sources.

## 20 Human Anatomy and Physiology (8)

**UC:CSU**

*IGETC Area 5B, 5C*

*CSUGE Area B2, B3*

*Prerequisite: Biology 3 or Biology 5*

*Lecture: 6 hours; Lab: 6 hours*

This course systematically integrates the fundamentals of human anatomy with the fundamentals of cellular as well as organ system physiology. Instruction and laboratory procedures (observation, experimentation, and dissection) are designed to provide a solid foundation in the anatomy, histology, and physiology of the eleven organ systems of the human body.

*Note: This single course is equivalent to both Anatomy 1 and Physiology 1 taken together.*

## 33 Medical Terminology (3) CSU

*Lecture: 3 Hours*

As a result of this survey course, students will be able to use the vocabulary appropriate to typical medical practice and medical specialties. Emphasis is placed on fundamental structure, pronunciation and spelling, as well as the use of standard medical dictionaries and references.

## BUSINESS

### 1 Introduction to Business (3) UC:CSU

*Lecture: 3 hours*

Introduction to the various forms of business. The student will study business management, organization, financing and marketing and will also become acquainted with the risks involved in business and with government's role in business.

### 5 Business Law I (3) UC:CSU

*Lecture: 3 hours*

This course covers the essentials of the law of contracts: agency, employment, personal property, bailment, sales, and real property in their application to everyday problems pertaining to business and to the individual. Elementary safeguards regarding sales and sales contracts are covered.

### 6 Business Law II (3) UC:CSU

*Prerequisite: Business 5*

*Lecture: 3 hours*

The course covers commercial paper -drafts, trade acceptances, checks, promissory notes; business organizations-partnerships, limited partnerships, corporations, and private franchises; agency, bankruptcy, contracts, and government regulation of business.

### 38 Business Computations (3) CSU

*Lecture: 3 hours*

This course provides the principles of mathematics, financial accounting and general business problems that include the following: Bank services including checking account and credit card account activity, payroll calculations, cash and trade discounts merchandise mark-up and inventory valuation, simple and compound interest, annuities, stock and bond transactions, business consumer loans, taxes and insurance, depreciation, financial

statements, ratios, and business statistics.

## CHEMISTRY

### 51 Fundamentals of Chemistry I (5)

**UC:CSU**

*IGETC Area 5A, 5C*

*CSUGE Area B1, B3*

*Corequisite: Math 115*

*Lecture: 4 hours; Lab: 3 hours*

This introductory course, which emphasizes the principles of inorganic chemistry, is an introduction to elementary organic and biological chemistry. It is planned primarily for non-science majors.

### 101 General Chemistry I (5) UC:CSU

*IGETC Area 5A, 5C*

*CSUGE Area B1, B3*

*Prerequisite: Chemistry 51 and Math 125*

*Lecture: 3 hours; Lab: 6 hours*

This course covers atomic theory and stoichiometry, states of matter, thermochemistry, and equilibrium. The study of gases, liquids and solutions, equilibria in gases and solutions, solubility and chemical bonding are also included in this course of study.

*Note: This course may not be offered each semester.*

*Consult the current class schedule.*

### 102 General Chemistry II (5) UC:CSU

*IGETC Area 5A, 5C*

*CSUGE Area B1, B3*

*Prerequisite: Chemistry 101*

*Lecture: 3 hours; Lab: 6 hours*

This course offers a study of principles related to properties of liquids, solids, and mixtures. Also covered are kinetics, chemical equilibrium and thermodynamics, acids and bases, and electrochemistry. The laboratory provides experience in inorganic qualitative analysis based upon content from lecture.

*Note: This course may not be offered each semester.*

*Consult the current class schedule.*

### 211 Organic Chemistry for Science Majors I (5) UC:CSU

*IGETC Area 5A, 5C*

*CSUGE Area B1, B3*

*Prerequisite: Chemistry 102*

*Lecture: 3 hours; Lab: 6 hours*

This course is a systematic introduction to the chemistry of carbon-containing compounds. It encompasses theory and chemistry of hydrocarbons and functional group derivatives. Topics included are bonding and structure, nomenclature, stereochemistry, synthesis, and reaction mechanisms. The laboratory work focuses on techniques of synthesis, isolation, purification and instrument analysis of organic compounds.

*Note: This course may not be offered each semester.*

*Consult the current class schedule.*

### 212 Organic Chemistry for Science Majors II (5) UC:CSU

*IGETC Area 5A, 5C*

*CSUGE Area B1, B3*

*Prerequisite: Chemistry 211*

*Lecture: 3 hours; Lab: 6 hours*

This course is a continuation of the study of organic compounds that started with Chemistry 211. Emphasis is placed on the synthesis of organic compounds and mechanisms of organic reactions. Topics on organic

molecules of biological importance such as amino acids, peptides and carbohydrates are also covered. The laboratory work focuses on the synthesis, isolation, purification, and instrumental analysis of organic compounds.

*Note: This course may not be offered each semester. Consult the current class schedule.*

## CHICANO STUDIES

### 2 The Mexican American in Contemporary Society (3) UC:CSU

CSUGE Area D3, D7

Lecture: 3 hours

This course investigates the most relevant issues facing the Chicano community today. Special attention will be given to the growth and impact of political behavior and under-representation, public health concerns, educational inequities, and immigration policies affecting Mexicans, Chicanos, and other Latinos.

### 4 Introduction to Chicana/o Studies (3) UC:CSU

CSUGE Area D3, D7

Lecture: 3 hours

This course is an introductory study of the discipline of Chicana/o Studies. This course examines race, ethnicity and culture in the Chicano/Latino community. It considers the movements for social change which created ethnic studies programs in the United States.

## CHILD DEVELOPMENT

### 1 Child Growth and Development (3) UC:CSU

CSUGE Area D7

Prerequisite: English 21

Limitation on Enrollment: TB Test Verification required

Lecture: 3 hours

An introductory Child Development course that examines the major physical, psychosocial, and cognitive/language developmental milestones for children, both typical and atypical, from conception through adolescence. There is an emphasis on interactions between maturational processes and environmental factors. While studying developmental theory and investigative research methodologies, students will observe children, evaluate individual differences and analyze characteristics of development at various stages.

### 2 Early Childhood: Principles and Practices (3) CSU

Corequisites: Child Development 1 and English 28

Limitation on Enrollment: TB Test Verification required

Lecture: 3 hours

A survey course which compares and analyzes historical as well as current models of early childhood programs. Students examine the underlying theoretical principles of developmentally appropriate practices applied to programs and environments. Emphasis is placed on the key role of relationships, constructive adult-child interactions and teaching strategies that support physical, social, creative and intellectual development of children and lead to desired learning outcomes. Professional development and career paths based upon CA Child Developmental Permit Matrix will be discussed.

### 7 Introduction to Curriculum in Early Childhood Education (3) CSU

Prerequisites: Child Development 2

Lecture: 3 hours

Students learn and develop the knowledge and skills to provide appropriate curriculum and environments for young children from birth to age 6. Students examine a teacher's role in supporting development and fostering the joy of learning for all young children using observation and assessment strategies emphasizing the essential role of play. Planning, implementation and evaluation of curriculum includes but not be limited to: language and literacy, social and emotional learning, sensory learning, art and creativity, math, natural and physical sciences.

### 8 Curriculum in Early Childhood Education (3) CSU

Prerequisite: Child Development 7

Lecture: 3 hours

Students design and evaluate developmentally appropriate curriculum and environments for young children from birth to age 8. Based on the value of play, students demonstrate the teacher's role in applying theory to practice in supporting children's concept development. Preparing and assessing the implementation of curriculum will include but not be limited to: language and literacy, social studies, art and creativity, music and rhythm, physical and motor mastery, mathematics, and physical sciences.

### 9 Advanced Curriculum: Art in Early Childhood (3)

Prerequisites: Child Development 1 and 2, English 28

Lecture: 3 hours

This course is an advanced exploration of visual art and creative curriculum in early childhood. Students are introduced to contemporary philosophies of art education and basic art concepts as they relate to early childhood education (birth - 8 years old). This course will emphasize the development of basic artistic and pedagogical skills, techniques, and strategies for working with young children to develop aesthetic perception and to promote creative expression. Further, this course provides a study of the importance of integrating art into the educational experience and examines the impact on overall child development for both typically and atypically developing children.

### 10 Health, Safety and Nutrition (3) CSU

Lecture: 3 hours

This course introduces the student to current information of laws, regulations, standards, concepts, policies and procedures in the field of health, safety, and nutrition and their relationship to young children. Special emphasis is placed on the key components that ensure physical health, mental health and safety for children will be identified along with the importance of collaboration with families and health professionals. This course is also intended for students to learn how teachers guide a child's development of habits and behaviors that influence life-long health.

### 11 Child, Family and Community (3) CSU

Lecture: 3 hours

This course is an examination of the developing child in a societal context focusing on the interrelationship of family, school and community and emphasizes historical and socio-cultural factors. The processes of socialization and identity development will be highlighted, showing the importance of respectful, reciprocal relationships that support and empower families.

### 12 Parent-Teacher-Child Interaction (3) CSU





*Lecture: 3 hours*

This course provides the student with a general overview of parental involvement and parents as partners in early childhood education. Special emphasis is placed on the integration and configuration of parent-child relationships, as well as on parent-teacher communication. The developmental context of socialization and its influence on families will be explored.

## **22 Practicum in Child Development I (4) CSU**

*Prerequisites: Child Development 1, 2, 3 and 4 or 7 and 8 and 34; English 28*

*Limitation on Enrollment: TB Test Verification required*

*Lecture: 2 hours; Lab: 8 hours*

This course is a supervised practicum experience in an early childhood educational setting. Students are assigned to the LASC Lab School or approved local Child Development programs to demonstrate developmentally appropriate early childhood teaching competencies under guided supervision of the college instructor and preschool classroom Master/Mentor teacher. Students utilize practical classroom experiences to make connections between theory and practice, develop professional behaviors, and build a comprehensive understanding of children and families. Child centered, play-oriented approaches to teaching, learning, assessment and knowledge of curriculum content areas is emphasized as student teachers design, implement and evaluate experiences that promote positive development, learning and social-emotional competence. CD 1, 2, 7, 8 and Eng. 28(or higher) are all prerequisites for this course. TB test clearance is also prior to placement at a practicum site.

## **23 Practicum in Child Development II (4) CSU**

*Prerequisites: Child Development 22 and 42*

*Limitation on Enrollment: TB Test Verification required*

*Lecture: 2 hours; Lab: 6 hours*

This course provides an advanced practicum experience. Students apply assessment strategies to plan, implement, and evaluate developmentally appropriate activities. Techniques that promote partnerships between teachers and families are developed. An educational philosophy statement, a resume and a professional portfolio are created. Students assigned to directed practicum teaching in a child development center demonstrate professional and ethical behaviors. Students will chose an area of specialization from the following areas: all-inclusive pre-school program, infants and toddlers, early intervention, special needs or school-age programs to do their internship during this specialization practicum course. The prerequisites for this course are CD 1,2,7,8,22,34,42, English 28 or higher and specialization courses (if applicable). This course builds on CD 22 foundational curriculum. State law requires a TB test (Mantoux Test) or chest x-ray. Please bring proof of your TB clearance to the first class. NOTE: In addition to the seminar class, students are required to complete a minimum of 108 hours, two days a week TBA, at an APPROVED field site.

## **30 Infant & Toddler Studies I (3) CSU**

*Recommended: English 21*

*Lecture: 3 hours*

This course provides an in-depth study of the physical, cognitive, social/emotional development of infants from birth to toddlerhood. Respectful care giving principles and practices, developmentally appropriate environment, adult relations, health and safety skills, and responsive curriculum designs for infants and toddlers are emphasized.

Students will learn strategies for observing infants in care giving settings.

## **31 Infant & Toddler Studies II (3) CSU**

*Recommended: English 21*

*Limitation on Enrollment: TB Test Verification required*

*Lecture: 3 hours*

This course provides principles of inclusive, respectful caregiving for infants and toddlers with a variety of program designs. Topics cover typical and atypical development appropriate environments, curriculum, health, safety, and licensing issues as well as observations, assessments, Family communications, home visiting, resources, and current research on brain development.

## **34 Observing and Recording Children's Behavior (3) CSU**

*Prerequisites: Child Development 1 and English 21*

*Recommended: English 21*

*Limitation on Enrollment: TB Test Verification required*

*Lecture: 3 hours*

This course examines strategies for observing and recording children's behavior. The student explores forms of documentation such as anecdotal records, running records, portfolios, checklists, rating scales, and other forms that help to guide curriculum, to document learning, and to communicate children's progress.

## **35 Fostering Literacy Development in Young Children (3) CSU**

*Limitation on Enrollment: TB Test Verification required*

*Lecture: 3 hours*

This course is designed for students interested in, or currently working in the field of, early childhood education. Students will build skills in promoting literacy in children from birth through age five. Students will also develop a strong foundation in early reading and writing within a developmentally appropriate approach.

## **36 Literature for Early Childhood (1) CSU**

*Lecture: 1 hour*

A survey of literature suited for children up to 8 years old with emphasis on techniques for selection and presentation. Storytelling, acquaintance with literature particularly suited for young children, and the early development of desirable attitudes toward reading will be stressed. Recommended for early childhood and primary grade teachers and parents

## **37 Literature for School Age Childhood (2) CSU**

*Lecture: 2 hours*

Survey of literature suitable for children in school settings, beginning with Pre-Kindergarten. Emphasis given to selection, preparation and presentation of literature utilizing a variety of genres and as well as methods of presentation. Recommended for early childhood and primary school teachers and parents.

## **38 Administration and Supervision of Early Childhood Programs I (3) CSU**

*Prerequisites: Child Development 1 and 2*

*Lecture: 3 hours*

This course prepares the student to establish and administer an early childhood program. Financial aspects of administration, regulations pertaining to administration, and the tools, philosophies, and techniques needed to operate an early childhood program are emphasized. The course partially fulfills the licensing requirements for the director.

### **39 Administration and Supervision of Early Childhood Programs II (3) CSU**

*Prerequisite: Child Development 1, 2 and 38*

*Lecture: 3 hours*

This course provides training for administrators of early childhood programs on a variety of topics pertaining to administering an early childhood program. Topics include: leadership principles and practices, decision making processes, supervision and staff development, conflict resolution strategies and building family partnerships.

### **42 Teaching in a Diverse Society (3) CSU**

*Lecture: 3 hours*

This course introduces the student to the social foundations and theory of multicultural and anti-bias education and instruction. The philosophy, principles, and methods related to teaching young children from diverse backgrounds are explored. Multicultural materials, media, activities, and curriculum plans are examined. A critical component of this course is the development of positive attitudes regarding gender equity and children with special needs.

### **44 Early Intervention for Children with Special Needs (3) CSU**

*Limitation on Enrollment: TB Test Verification required*

*Lecture: 3 hours*

This course is designed for students interested in specializing in or working with children with special needs. Instruction focuses on accommodating and adapting the physical environment, instructional strategies and curriculum to meet the needs of differently-abled children and their families.

### **45 Programs for Children with Special Needs (3) CSU**

*Recommended: English 21*

*Limitation on Enrollment: TB Test Verification required*

*Lecture: 3 hours*

This course is an introduction to the study of exceptional children including classification and special characteristics. The focus is on general program planning as well as adapting daily activities in inclusive early childhood settings.

### **46 School Age Programs I (3) CSU**

*Recommended: English 21*

*Limitation on Enrollment: TB Test Verification required*

*Lecture: 3 hours*

This course is an introduction to strategies used in child development programs for school age children. It includes understanding the growth and developmental skills and needs of school age children and the teacher's role in children's development. Characteristics of an effective school age teacher will be explored.

### **47 School Age Programs II (3) CSU**

*Prerequisite: Child Development 46*

*Limitation on Enrollment: TB Test Verification required*

*Lecture: 3 hours*

This course explores developmentally appropriate program planning in child development programs for school age children. It includes guidelines for practices that are most effective in promoting children's learning and development. Emphasis is placed on curriculum development, planning for cultural and linguistic diversity and understanding environment and its impact on development. Quality and standards for school age programs as well as assessing children's progress will be explored.

### **48 Positive Guidance in Early Childhood Settings (3) CSU**

*Recommended: English 21*

*Limitation on Enrollment: TB Test Verification required*

*Lecture: 3 hours*

This course provides exploration of developmentally appropriate management techniques for children in early childhood settings. Emphasis is on developing culturally sensitive individualized plans for behavior management of children including children with special needs.

### **65 Adult Supervision/Early Childhood Mentoring (2)**

*Prerequisite: Child Development 2*

*Recommended: English 21*

*Lecture: 2 hours*

This course is a study of the methods and principles of supervising student teachers in early childhood classrooms. The course will emphasize the role of classroom teachers who function as mentors to new teachers while simultaneously addressing the needs of children, parents and other staff.

## COMMUNICATION STUDIES

### **101 Public Speaking (3) UC:CSU**

*IGETC Area 1C*

*CSUGE Area A1*

*Lecture: 3 hours*

Students study the theory and techniques of public speaking in a democratic society. They learn discovery, development, and criticism of ideas in public discourse through research, reasoning, organization, composition, presentation, and evaluation of various types of speeches including informative and persuasive extemporaneous public speeches utilizing effective outlines, structure and style.

### **104 Argumentation and Debate (3) CSU**

*Lecture: 3 hours*

Methods of critical inquiry and advocacy. Identifying fallacies in reasoning and language, testing evidence and evidence sources, advancing a reasoned position, and defending and refuting arguments. Analysis, presentation, and evaluation of oral and written arguments.

### **106 Forensics (2) CSU**

*Activity: 7 hours*

This course provides advanced training in public speaking, oral interpretation, argumentation skills and intercollegiate competition in public debate.

### **121 Interpersonal Communication (3) CSU**

*Lecture: 3 hours*

Principles of verbal and nonverbal transactions that occur in relationships. Study of theory and research findings and their application to communication in interpersonal relationships in personal and professional contexts.

### **122 Intercultural Communication (3) CSU**

*Recommended: English 28 or English 363*

*Lecture: 3 hours*

This course examines communication in the context of intercultural interactions, explores verbal and nonverbal communication similarities and differences in communication across cultures, and provides strategies to enhance interpersonal communication skills within the context of intercultural communication.

**130 Introduction to Oral Interpretation of Literature (3) UC:CSU**

CSUGE Area C2

*Lecture: 3 hours*

Students will develop the ability to understand, appreciate, relate to, and perform various forms of literary art. Emphasis is placed on the selection and adaptation of worthwhile literary material, as well as on artistic and effective vocal and gestural presentation.

**151 Small Group Communication (3) CSU***Lecture: 3 hours*

This course provides an analysis of the purposes, principles, and types of small group processes. Development of individual skills in leadership, problem solving, is achieved by responsible small group participation.

**190 Communication and New Media (3) CSU***Lecture: 3 hours*

This course introduces computer-mediated communication. Students examine how the Internet, specifically popular culture, social media, websites, blogs, podcasts, YouTube, and social networks, have reshaped communication practices. The course offers an overview of relevant theories and critical issues while providing students with the opportunity to apply communication skills using new media.

## COMPUTER APPLICATIONS AND OFFICE TECHNOLOGIES (CAOT)

**1 Computer Keyboarding I (3) CSU***Lecture: 2 hours; Lab: 3 hours*

This course instructs students in proper keyboarding techniques to accomplish mastery of the computer keyboard by touch. Students will develop speed and accuracy and produce basic business documents such as business letters, reports, and tables using word processing software.

**1A Computer Keyboarding IA (1) CSU***Lab: 2 hours*

This course instructs students in proper keyboarding techniques to accomplish mastery of the computer keyboard by touch. Students will develop speed and accuracy.

**2 Computer Keyboarding II (3) CSU***Lecture: 2 hours; Lab: 3 hours*

Mastery of the keyboard and basic operations of typing are developed. Emphasis is placed on formatting and producing letters and tables using Microsoft Word.

**3 Computer Keyboarding III (3) CSU***Prerequisite: CAOT 2**Lecture: 2 hours; Lab: 3 hours*

Develops speed and accuracy between 50-55 net words per minute. The student learns more of producing specialized forms and reports, such as business reports, legal and accounting papers. The course specifically emphasizes shortcuts in handling of materials, statistical input and development of 'thinking at the computer keyboard;' develops production skills in using advanced features of the Word processing program being used to

create properly formatted business documents which includes composition at the keyboard, decision making, and timed production of letters, tables, and reports. Develops minimum speed of 50 net wpm.

**5 Introduction to Computerized Medical Records Management (1)***Prerequisite: CAOT 33**Lecture: 1 hour*

This course is designed to prepare students to work with commercial software used in hospitals, doctor's offices, health clinics, insurance companies, and other health-related organizations.

**8 Computerized Office Records Management (1)***Prerequisite: CAOT 33**Lecture: 1 hour*

This course is designed to prepare students to work with commercial software used in various business organizations today.

**31 Business English (3) CSU***Lecture: 3 hours*

This course offers the student a review of, and training in, the fundamentals of English grammar as applied to current Business English. Emphasis is placed on reference skills, parts of speech, sentence structure, word usage, business vocabulary, and current business writing conventions.

**33 Records Management and Filing (2)***Lecture: 1 hour; Lab: 2 hours*

This course covers the standard rules and principles of indexing and filing as well as information management principles, operations, and organization. The student will receive training in filing methods used most frequently, including alphabetic, subject, numeric and geographic procedures as well as record systems and control.

**34 Business Terminology (2) CSU***Lecture: 2 hours*

This course is designed to develop word command by increasing vocabularies, enabling students to use relevant words in both written and oral communications and become acquainted with specialized business-related terminologies that help prepare students not only for a business career but also for consumer transactions in today's world.

**35 Concepts In Information Systems (3) CSU***Lecture: 3 hours*

This course is intended to provide students with the basis for understanding the concepts necessary for success in the Information Age. It provides an introduction to the basic concepts of personal computer literacy, including operating systems software, internet browsers (MS Internet Explorer), (MS Windows), word processing, (MS Word,) spreadsheets (MS Excel), and presentation software (MS PowerPoint).

**64 Computer Applications and Office Technologies Laboratory (1) CSU Pass/No Pass RPT 3***Lab: 2 hours*

Develops competency in the subject areas taught in the Computer Applications and Office Technologies Department. Designed as an aid to students who need additional time and practice to increase their knowledge

and skills in any computer applications and office technologies course.

## 82 Microcomputer Software Survey in the Office (3) CSU

*Lecture: 2 hour; Lab: 3 hours*

This course provides hands-on experience using the Microsoft Office Suite including Word, (word processing), Excel (spreadsheet), Access (database), PowerPoint (presentation graphics) and Outlook (personal information manager). Student gain core level skills necessary to design, create, and edit word processing documents, spreadsheets, databases, and presentations. Students develop proficiency in basic computer skills including Outlook and using Windows GUI interface.

## 84 Microcomputer Office Applications: Word Processing (3) CSU

*Prerequisite: CAOT 1 and 1D*

*Lecture: 2 hour; Lab: 3 hours.*

This course provides information and hands-on training on the use of Microsoft Word. Students will learn how to create, edit, and manipulate various types of documents. Students will create, format, edit, save, and print documents including letters, memoranda, tables and reports. Shared documents and mail-merge are also presented.

## 85 Microcomputer Office Applications: Spreadsheet (3) CSU

*Lecture: 1 hour; Lab: 4 hours*

This course provides a detailed study of business applications using Microsoft Excel or a similar software. Topics include the commands, formats, and functions of spreadsheet software with an emphasis on its use as a problem solving and financial analysis tool. Students will learn formulas, conditional formatting, charts, macros, editing, formatting and linking of worksheets. Emphasizes preparing computerized worksheets, using advanced formulas and functions to analyze data, prepare charts, and simplify office accounting procedures.

## 97 Internet for Business (3)

*Lecture: 2 hours; Lab: 3 hours*

Introduction to the Internet for Office Administration (3) Lecture 3 hour; Laboratory 2 hours. Acceptable for credit, California State University This course provides hands-on experience with the Internet and World Wide Web using web browser software like Microsoft Internet Explorer and Netscape Navigator to find, access and use information from the Internet. Students will develop the skills to create, send and receive E-mail and Instant Messages using web based software. Students will learn how to find, evaluate, and select Internet Service Providers, E-commerce sites, and research resources. Skill will be developed to explore business, career, government, news, reference databases, travel, and other internet services and utilities. Students will learn the fundamentals of web page design and how to design and create basic web page using HTML.

## 107 Microcomputer Office Applications: Web Design for the Office (3) CSU

*Prerequisite: CAOT 112*

*Lecture: 2 hours; Lab: 3 hours.*

This course provides skills to utilize advanced web design tools. Students design, build, and publish web sites using Adobe Dream Weaver, advanced HTML, the basic concepts of Java script and Java applets. Students will use graphics, style sheets, hyperlinks, tables, forms, and

multimedia

capabilities to create advanced web sites for the high-tech office environment.

## 108 Presentation Design for the Office (2) CSU

*Recommended: CAOT 82*

*Lecture: 1 hour; Lab: 2 hours*

This course provides the skills to use presentation authoring software like Microsoft PowerPoint to design, modify, and create professional-looking multi-media presentations. Students will develop presentations that include dynamic and static links, graphic elements, tables, charts, diagrams, sound, animation and other enhancement features. Students will also learn how to convert their presentations into dynamic web site elements.

## 109 Web Multimedia for the Office (3) CSU

*Prerequisite: CAOT 82*

*Recommended: CAOT 113*

*Lecture: 2 hours; Lab: 3 hours*

This course provides hands-on design and implementation skills using multimedia Web design tools. Students will incorporate video, sound, graphics, animation, and other multimedia capabilities related to website production in the high-tech office environment.

## 112 Microcomputer Office Applications: Web Page Design (3) CSU

*Prerequisite: CAOT 82*

*Lecture: 2 hours; Lab: 3 hours*

This course will provide the skills to design, modify, create, and publish web pages using HTML/XHTML. Students will develop multipage web sites using HTML/XHTML that include links, graphic elements, tables, style sheets, templates, forms and other enhancement features. An understanding of HTML/XHTML will be developed, along with the ability to troubleshoot and improve website design.

## 113 Introduction to Adobe Photoshop for the Office (3) CSU

*Prerequisite: CAOT 82*

*Lecture: 1 hour; Lab: 4 hours*

This course is an introduction to graphics design using Adobe Photoshop. The class will focus on the basic elements of computer graphic arts software for business, digital layout, rendering and manipulation of computer and still imagery. Among the skills covered will be: selection tools, layers, channels, masks, painting tools, image editing, applications of filters, integration of text, and the combining of images.

## 127 Introduction to Digital Video (3) CSU

*Prerequisite: CAOT 82*

*Recommended: CAOT 113*

*Lecture: 1 hour; Lab: 4 hours*

This course prepares students to use digital video for multimedia presentations and will cover basics of shooting and editing digital video, as well as provide a basic comprehension of concepts for shooting digital video. Students will produce 2-3 minute video presentations, edit and market their videos for uploading to video sharing websites.

## 133 How to Succeed in an Online Course

**(1)***Lecture: 1 hour; Lab: 0.5 hours*

This course is intended for students wishing to enroll for the first time in an online class. It covers the basic navigation of the online environment including how to post to forums, take quizzes, submit assignments, etc. as well as the soft skills needed to be successful in an online environment.

**134 How to Teach an Online Course (1.5)***Lecture: 1 hour; Lab: 1 hour*

This is a class that prepares instructors to use online components in both traditional classes and online classes and to use a common Course Management System to facilitate their courses. This class will give instructors actual online class experience as students, expose them to pedagogy of online classes, and to help them prepare their own course material.

**150 Social Media for Business (3) CSU***Prerequisite: CAOT 82**Lecture: 1 hour; Lab: 4 hours*

Students will learn how to promote their business on the popular social networking websites. Topics include web marketing, video sharing, blogging, RSS feeds, creating a fan base, and building traffic to your website and business. Students will learn how social media websites can be a tool to promote and expand their online presence.

**255 Electronic Commerce (E-Commerce) (3) CSU***Prerequisite: CAOT 82**Lecture: 1 hour; Lab: 4 hours*

Students will learn to identify and understand fundamental terms and concepts related to E-Commerce, recognize the evolution of e-commerce, and have an understanding of aspects pertinent to selling and marketing on the Internet. Students will research current e-commerce trends and topics such as b2b and b2c. Successful e-commerce case studies will be analyzed in the class.

**941 Cooperative Education-CAOT (4) CSU***Lecture: 4 hours*

Computer Applications Office Technology is approved for Cooperative Education, Work Experience, and Internships. See listing under Cooperative Education.

## COMPUTER SCIENCE AND INFORMATION TECHNOLOGY

**600 Practical PC and Career Technologies****(1)***Lecture: 0.5 hours; Lab: 1.5 hours*

This is a basic course in computer literacy concepts. It provides an overview of Windows-based PCs. Basic Microsoft Windows, installing software; naming and saving files, compressing and decompressing files, downloading files, organizing files in folders, as well as protecting files will be introduced. The class will also cover how to connect to and search the Internet, and how to send e-mail with attachments. The students will assess implications of computer technology on society. Students will be introduced to college resources that assist them in entering the computer field and complete their programs successfully. In-demand careers in technologies will be discussed to boost student interest in Science, Technology, Engineering, Math, and increase their employability in the field of Computer Science.

**601 Introduction to Computers and Their Uses (3) UC:CSU***Lecture: 2 hours; Lab: 2 hours*

This is a basic course in computer literacy concepts. It provides an overview of computer networking, hardware and software (including operating systems and file management). The students will assess implications of computer technology on society.

**602 Introduction to Computer Science (3) UC:CSU***Prerequisite: Computer Science 630**Lecture: 2 hours; Lab: 2 hours*

This is a breadth-first course covering basic concepts and principles of computer science. Specifically, it covers the behavior of gates and circuits using Boolean expressions, truth tables, logic diagrams as well as the von Neumann machine. Students apply top-down methodology to develop algorithms for problem solving.

**607 Programming Logic and Design (3) CSU***Prerequisite: Computer Science 601**Lecture: 2 hours; Lab: 2 hours*

This course covers essentials of programming logic, algorithm design and development including: constants, variables, expressions, arrays, files, and control structures for sequential, iterative, and decision processing. File handling, propositional logic, predicate logic, object-oriented programming and event-driven GUI programming, animation, and exception handling will be introduced. Students develop program design skills and general problem solving skills by applying structured programming techniques to program specifications using tools such as flowcharts and pseudocode. Validation through desk-checking and walk-through techniques are also covered. This course covers lab exercises which allow the students to demonstrate the concepts discussed and learned.

**608 Beginning BASIC Programming (3) UC:CSU***Prerequisite: Computer Science 630**Lecture: 2 hours; Lab: 2 hours*

This course provides an introduction to Visual Basic, a modern and very powerful, yet easy-to-learn programming language. It covers the integrated development environment (IDE), traditional and event-driven programming concepts, visual programming features, and a brief introduction to object-oriented programming (OOP).

**609 Beginning Java Programming (3) UC:CSU***Prerequisite: Computer Science 630**Lecture: 2 hours; Lab: 2 hours*

This course teaches the fundamental principles of object-oriented programming design and concepts, using the Java programming language. It teaches the basics of the Java programming language using the latest version of the Java Standard Edition Development Kit. Students learn to design and develop programs using the following programming constructs and techniques: Data representation using variable and constant objects; sequential, selection and repetition control structures; designing classes, methods and functions; use of arrays to sort and search data lists; and designing graphics applications and Applets.

**611 Cyber Security I (3) CSU**

*Recommended: Computer Science 630*

*Lecture: 2 hours; Lab: 2 hours*

This course is the first in the series of two that present the theory and practice of information systems security. It covers the basics of Windows architecture, the differences in the versions, the installation, and configuration of both stand-alone and networked systems. It explains and explores the main network communications protocols, such as TCP/IP, their proper configurations, network management utilities and tools. Network administration tools such as Windows User accounts, User Account Permissions and Privileges are covered. It also covers the features of servers and their unique security considerations. This course includes coverage of threats, vulnerabilities and the techniques, tools, and best practices used to discover, prevent and/or mitigate these threats and vulnerabilities.

**616 Introduction to Computer Architecture and Organization (3) UC:CSU**

*Prerequisite: Computer Science 602*

*Lecture: 2 hours; Lab: 2 hours*

This course covers computer architecture. Topics include information representation and storage organization in computer systems, computer hardware components, typical computer architectures, instruction formats, addressing modes, subprograms, parameter passing, system and user stacks, the instruction execution cycle, assembly language instruction formats, compiler translation to assembly language, optimizing compilers, disassemblers, loaders and simulators, system interrupts, memory allocation process with virtual memory, Boolean algebra and logic gates, and combinational and sequential devices.

**617 Beginning Micro Assembly Language (3) CSU**

*Prerequisite: Computer Science 602*

This is an introductory course designed to teach students the basic concepts behind the classic von Neumann machine architecture. This course covers fundamental concepts in information representation, computer organization, assembly language programming, and computer architecture. The course emphasizes computer science topics that are related to the foundation of computer hardware and its associated software.

**621 Certified Internet Webmaster Associate (CIWA): Internet Fundamentals (3) CSU**

*Prerequisite: Computer Science 601*

*Lecture: 2 hours; Lab: 2 hours*

This is the first in a series of three courses for the CIW (Certified Internet Webmaster) Internet skills certification program. It is designed to guide students through the use of key internet, Intranet, and Extranet technologies. Students will gain experience configuring both Netscape Navigator and Microsoft Internet Explorer to access rich multimedia content. Students will use Plug-ins to enhance the functionality of Navigator and Internet Explorer. Additionally, they will be introduced to a variety of search engines and the basics of electronic commerce and email, and they will investigate security issues.

*Note: This course is endorsed by the International Webmasters Association (IWA) and the Association of Internet Professionals (AIP).*

**622 Certified Internet Webmaster Associate (CIWA): Web Page Authoring Fundamentals****(3) CSU**

*Prerequisite: Computer Science 621*

*Lecture 2 hours; Lab: 2 hours*

This is the second in a series of three courses for the CIW (Certified Internet Webmaster) Internet skills certification program covering Web page creation and other aspects of Web authoring. Students are introduced to the development of Web pages in a text editor and graphical user interface (GUI) editor. Students will create Web pages containing text, graphics, hyperlinks, tables, forms and frames. They also will use Cascading Style Sheets (CSS) and study the basics of Extensible Hypertext Markup Language (XHTML), JavaScript, Dynamic HTML (DHTML) and the Document Object Model (DOM).

*Note: This course is endorsed by the International Webmasters Association (IWA) and the Association of*

**623 Certified Internet Webmaster Associate (CIWA): Networking Fundamentals (3) CSU**

*Prerequisite: Computer Science 622*

*Lecture 2 hours; Lab: 2 hours*

This is the third in a series of three courses for the CIW (Certified Internet Webmaster) Internet skills certification program. This course presents fundamental networking concepts and practices. Topics include network architecture and standards, network types, protocols, Internet servers, TCP/IP, and security.

*Note: This course is endorsed by the International Webmasters Association (IWA) and the Association of Internet Professionals (AIP).*

**630 Microcomputer Application Software (3) CSU**

*Prerequisite: Computer Science 601*

*Lecture 2 hours; Lab: 2 hours*

This course covers applications and development software for microcomputers. Topics covered include basic operating systems, file management, wired and wireless networks, Network Applications Providers (NAP), Network Service Providers (NSP), and Internet Service Providers (ISP). The course also covers the relationship between HTML, XHTML, HTTP, URLs, browsers, and Web servers and application processing of digital video and 3-D animation. It provides an overview of enterprise-wide information systems, basic database concepts and object oriented programming.

**632 Introduction to Databases (3) CSU**

*Prerequisite: Computer Science 630*

*Lecture: 3 hours*

This course covers the concepts of database structures and design involving the physical and logical structures and the environments in which they can be applied. Students will gain a comprehensive coverage of the database features including creating and maintaining a database, creating simple and advanced queries, creating standard and custom forms and reports, enhancing table design, automating tasks with macros, working with layout view, interactive form and report design capabilities, and changes to security features. This course provides students with a solid understanding of important database concepts, including database design, field properties, table relationships, join types, splitting a database, object dependencies, normalization, and naming conventions. The three major approaches to the application of databases are included: relational, hierarchical, and network. Students will have a variety of hands-on and case project assignments that reinforce the database concepts. This course meets the requirements for the Microsoft Certified Application Specialist exam for Microsoft Office Access 2007.



### 636 Introduction to Data Structures (3)

#### UC:CSU

*Prerequisite:* Computer Science 639

*Lecture:* 2 hours; *Lab:* 2 hours

Introduction to the study of data structures formed from primitive data types; the role of abstract data types (including stacks, queues, lists, trees, and graphs) and their definitions, implementation and application in program design and algorithms that use them; recursion; use of complexity analysis in evaluating algorithms.

*NOTE:* This course conforms to the ACM Freshman-Sophomore level Data Structures (CS2) course.

### 639 Programming in C (3) UC:CSU

*Prerequisites:* Computer Science 601 and Computer Science 607

Coverage includes data types, operators and expressions, control flow, functions and program structure, pointers, arrays, arrays of pointers, structures, I/O, and text files. Examples illustrate programming techniques, algorithms, and the use of library routines.

### 641 Computer Forensics I (3) CSU

*Prerequisite:* Computer Science 630

*Lecture:* 2 hours; *Lab:* 2 hours

This course covers computer forensics fundamentals, providing an overview of computer forensic types, techniques, their electronic evidence and capture. Students learn a systematic approach to conducting a computer forensics investigation, both a law enforcement and a corporate investigation. They also investigate the requirements of a computer forensics lab including data recovery workstations, hardware and software and what is required to certify a computer forensics lab. They will learn how to collect evidence at private-sector incident scenes as well as at a crime scene using state-of-art data acquisition tools. The course also covers the purpose and structure of file systems such as New Technology File System (NTFS) as well as methods for validating and testing computer forensics tools.

### 642 Computer Forensics II- Investigating Hard Disk, File and Operating Systems (3) CSU

*Prerequisite:* Computer Science 641

*Lecture:* 2 hours; *Lab:* 2 hours

Computer Forensics is the science of identifying, recovering, extracting, preserving, and documenting ESI (Electronically Stored Information). This course is the 2nd in a series of 5 courses leading to the nationally recognized EC Council certification in Computer Hacking Forensic Investigator (CHFI). The course provides a basic understanding of file systems, computer storage devices and other digital media devices. It covers the hardware Boot processes for Windows, Linux and the Macintosh operating systems. The process of collecting volatile and nonvolatile information and performing analysis of operating systems memory, registry and files are covered. The course also covers forensic analysis of event log, audit events and password issues including the applications of password crackers.

### 644 Computer Forensics IV (3) CSU

*Prerequisite:* Computer Science 641

*Lecture:* 2 hours; *Lab:* 2 hours

Computer Forensics is the science of identifying, recovering, extracting, preserving, and documenting ESI (Electronically Stored Information). This course is the 4th in a series of 4 courses leading to the nationally recognized

EC Council certification in Computer Hacking Forensic Investigator (CHFI). This course covers investigating computer network forensics, network traffic, Web attacks, router forensics, Denial of Service (DoS) attacks, Internet crimes, tracking e-mail, corporate espionage, trademark and copyright infringement. It also discusses investigative procedures for social issues such as sexual harassment forensic, child pornography and the role of the Internet in promoting these inappropriate usage of technology.

### 646 Discrete Structures for Computer Science (3) CSU

*Prerequisite:* Computer Science 602

*Lecture:* 2 hours; *Lab:* 2 hours

This course is an introduction to the discrete structures used in Computer Science with an emphasis on their applications. Topics covered include: Number Systems & Systems for Basics of Counting; Regular Expressions; Functions, Relations and Sets; Combinational Circuits & Digital Logic; Basic Formal Logic; Proof Techniques; Basics of Counting; Recursive Programming & Algorithms; Graphs and Trees; Discrete Probability and Finite State Automata. This course is compliant with the standards of the Association for Computing Machinery (ACM).

### 660 Business Systems Design (3) CSU

*Prerequisite:* Computer Science 630

*Lecture:* 3 hours.

This course is subtitled 'Systems Analysis, Design & Documentation.' It covers the five phases of the System Development Life Cycle (SDLC). Specifically, it deals with the process of analyzing, designing, and implementing business information system. Emphasis are placed on the role of the systems analyst. The student learns to apply the tools and techniques of the analyst to study, design, update, implement, document and transfer modern day information systems. The case study approach is used throughout the course.

### 680 Network Security Fundamentals (3) CSU

*Prerequisite:* Computer Science 601

*Lecture:* 3 hours; *Lab:* 3 hours

This course provides students with a complete introduction to practical network and the fundamentals of computer security and maps to the CompTIA Security+ SY0-301 Certification Exam. Students will learn a full range of security concepts and techniques and how to apply them to the most popular operating systems and application used today. This course covers the fundamentals of network security, including compliance and operational security; threats and vulnerabilities; application, data, and host security; access control and identity management; cryptography and public key infrastructure; and auditing and intrusion detection. New topics such as psychological approaches to social engineering attacks, Web application attacks, penetration testing, data loss prevention, cloud computing security, and application programming development security will be introduced. This course features lab simulation, involves security settings on client and server operating systems and activities that link to the Information Security Community Site, which offers video lectures, pod casts, discussion boards, additional hands-on activities and more to provide a wealth of resources and up-to-the minute information.

### 681 Introduction to Computer Networking (4) CSU

*Prerequisite:* Computer Science 601

*Lecture:* 3 hours; *Lab:* 2 hours

This course presents the theory and practice of computer networking. It covers the principles and techniques used in designing data networks. Topics include networking theory and concepts, network design and implementation including topologies, networking media & interface, Open System Interconnection (OSI), network communications and protocols, network architecture, simple and complex network operations, modeling and performance analysis of various type of networks including (LANs, WANs, and WiFi), maintenance and troubleshooting, and network security. This course has a comprehensive coverage of fundamental networking technologies, with a focus on major operating systems.

### **682 Computer Networking II (4) CSU**

*Prerequisite: Computer Science 681*

*Lecture: 3 hours; Lab: 3 hours*

This course prepares students to administer and support contemporary network operating systems (NOS) server environments. Topics include planning for server deployment, installation, configuration, Active Directory and accounts management, preparation for server management, monitoring and maintaining servers security and policies, planning for business continuity and high availability. Students will be prepared to pass the MCITP 70-646 certification exam. Focusing on updates to the software and in-depth coverage of the administration aspects of the deployed server will be introduced in this course. Hands-on labs will be conducted in this course to emphasize the covered topics.

### **683 Principles of Information Security (2) CSU**

*Prerequisite: Computer Science 601*

*Lecture: 2 hours*

*Lab: 2 hours*

This course explores the field of information security and assurance with content including new innovations in technology and methodologies. Students will revel in the comprehensive coverage that includes a historical overview of information security, discussions on risk management and security technology (Firewalls and VPNs), current certification information, legal, ethical, and professional issues in information security. Cryptography, physical security, and implementing information security will be covered. This course builds on internationally-recognized standards and bodies of knowledge to provide the knowledge and skills students need for their future roles as business decision makers. Students can feel confident that they are using a standards-based, content-driven resource to prepare for their work in the field. This course features lab exercises which allow the students to apply the basics of their introductory security knowledge in a hands-on environment.

### **688 Computer Project (2) CSU**

*Prerequisite: Computer Science 639*

*Lab: 4 hours with homework*

The student, after consultation with the instructor, is to design, develop, and evaluate a project involving the application of the computer. Emphasis in this course is placed on a maximum of independent study and research.

### **691 Computer Programming Laboratory (1) CSU**

*Lab: 3 hours*

This course provides the opportunity for students to work in a laboratory setting to review, develop and complete computer related project(s) using the hardware, software, and related laboratory resources.

## COMPUTER TECHNOLOGY

### **1 Introduction to Computers for Technicians (4) CSU**

*Lecture: 3 hours; Lab 3: hours*

In this first course for the computer technology majors, students will learn about the architecture, layout of motherboards, and the physical aspects of computer hardware including the peripherals, and key elements of Microsoft office and low-level programming.

## COUNSELING

### **6 Career Planning for Students with Disabilities (1) CSU**

*Lecture: 1 hour*

This course is designed to assist students with disabilities in the exploration and development of career goals. Topics include; goal setting, career assessments/exploration, job seeking strategies (internships & informational interviews), resume writing, interview skills, dressing for success and the impact of the Americans with Disabilities Act in the workplace.

### **17 College Survival Skills Development (1) CSU**

*Lecture: 1 hour*

This course provides students with a variety of survival skills necessary to be a successful college student. Topics include the matriculation process, library resources and usage, study skills strategies, self-esteem, time and stress management and goal setting.

### **20 Post-Secondary Education: The Scope of Career Planning (3) UC:CSU**

*Lecture: 3 hours*

This course provides the student with in depth career and life planning. Course content includes extensive exploration on one's values, interests and abilities; life problem-solving and self-management skills; adult development theory and the transitional changes that happen over the life span; self-assessment including one's skills and matching personality with work environment. An intensive career investigation; decision-making, goal setting, networking and job search strategies, as well as resume writing and interviewing skills will also be addressed.

### **40 College Success Seminar (3) CSU**

*Lecture: 3 hours*

This course introduces students to the study of the educational, psychological, intellectual, social, and health-related factors that impact lifelong learning, well-being, and success. Topics include factors affecting internal and external motivation, critical thinking, effective learning strategies, interpersonal and cross-cultural communication, health and wellness issues, effective written and oral communication strategies, life management strategies, career exploration and educational planning.

## DANCE

### **022 Jazz Dance (1) UC:CSU RPT 3**

*IGETC Area*

*CSUGE Area*

*Activity: 2 hours*

This course offers instruction and preparation in the skill of jazz dance.





## DANCE STUDIES

### 301 Choreography I (1) CSU

*Prerequisite:* DANCETQ141, or 111 or 121

*Lab:* 2 hours

Students choreograph and perform dances with emphasis on energy space and time using basic steps and combinations, spacing, design, terminology, and music. Students learn an appreciation of dance as a performing art form.

### 814 Dance Production I (2) CSU

*Lecture:* 1 hours; *Lab:* 2 hours

Provides instruction and laboratory experience in methods and techniques involved in producing a dance concert, including publicity, lighting, costuming, audition and performance skills, and dance critique and assessment.

## DANCE TECHNIQUES

### 111 Ballet Techniques I (1) CSU

*Lab:* 2 hours

Students learn basic Ballet steps and combinations at an introductory level, terminology, music, and appreciation of dance as a performing art.

### 121 Jazz Dance Techniques I (1) CSU

*Lab:* 2 hours

Students learn beginning jazz dance technique with an emphasis on basic steps, combinations, terminology, music, and appreciation of dance as a performing art form.

### 141 Modern Dance Techniques I (1) CSU

*Lab:* 3 hours

Teaches technique, principles, terminology and the practice of modern contemporary dance at the introductory level. Students will undergo an in depth exploration of how the body is used in modern dance technique with a focus on alignment, body part initiation, body organization and sequencing. The course will also include the history of modern dance and an introduction to the elements of space, time, and energy through improvisational and choreographic exercises. Students will develop coordination, flexibility, and cardiovascular strength using various movement combinations.

## EARTH SCIENCE

### 2 Earth Science Laboratory (3) UC:CSU

*Corequisite:* Earth Science 1

*Lecture:* 1 hour; *Lab:* 2 hours

Earth Science Laboratory supplements Earth Science Lecture. Students are introduced to the study of Earth materials by learning to identify common minerals and rocks. Interpretations of processes acting on and within the Earth are approached through the study of information contained in maps, aerial photographs, and data sets collected from a variety of Earth-sensing instruments.

## ECONOMICS

### 1 Principles of Economics I (3) UC:CSU

*IGETC Area 4B*

*CSUGE Area D2*

*Prerequisite:* Math 115

*Lecture:* 3 hours

This course provides an introductory of microeconomic analysis and their application to business situation. Emphasis is on supply and demand, elasticities, consumer choice optimization, profits, economic rent, financial environment of business, market structure, economic and social regulations, antitrust policy in a globalized economy.

### 2 Principles of Economics II (3) UC:CSU

*IGETC Area 4B*

*CSUGE Area D2*

*Prerequisite:* Math 115

*Lecture:* 3 hours

This is an introductory course in the principles of macroeconomics theory. Measurements of aggregate economic performance including GNP and National Income, money and banking; business cycle, role of the government and the Federal Reserve System (fiscal and monetary policies), economic growth and stability, international trade, and economics of underdevelopment are covered in this course.

## EDUCATION

### 1 Introduction to Teaching (3) CSU

*Lecture:* 3 hours

This course explores effective teaching styles and strategies. Students learn about the history of our nation's education system and contemporary educational issues. Larger societal issues are also included as they pertain to the education system. Students will create and present a lesson plan.

### 6 Methods and Materials of Tutoring (1)

*Lecture:* 1 hour; *Lab:* 1 hours

This course trains students in individual and group tutoring and instructional techniques, group dynamics, interpersonal skills, and organizational skills related to academic success. Tutoring and instructional strategies that promote independent learning are discussed.

### 203 Education in American Society (3)

**UC:CSU**

*Lecture:* 3 hours

This course is designed to provide future teachers with the fundamental knowledge essential for understanding the American educational enterprise, especially issues in urban multicultural schools. Concepts and methods from the fields of sociology, philosophy, and the politics of education are used to analyze the current conditions of American schools and to evaluate selected proposals/models for reform.

### 204 Introduction to Teaching: Education For Global Citizenship (3) CSU

*Lecture:* 3 hours

This course will examine issues facing local, national, regional, and global communities. The workshop format of this course will allow for the investigative study of 'Global Citizenship,' encapsulating the social, environmental, cultural, political, economic, cross-border, international, and human rights issues that affect real people in countries and local communities, which surround us. Students will have the opportunity to experience, experiment and reflect on their role as global citizens.

### 205 Diversity in Teaching: Teaching for Diverse Populations (3) CSU

*Prerequisite:* English 28

*Lecture:* 3 Hours

This course is designed to examine the concepts, principles, theories, and practices for teaching diverse student populations. The end objective is to cultivate the knowledge and skills necessary to address the issues that present themselves in multicultural classrooms and classrooms containing students with specific academic needs, such as students with special needs, English Learners, and gifted and talented students. To accomplish this, we will use ourselves as a starting point—our individual thoughts, opinions, feelings

about multiculturalism, gender, racism, and prejudice so that we may shape our teaching philosophy to reflect the needs of a diverse classroom. Throughout the course we will explore strategies for creating classroom learning environments that value and integrate diversity as well as addressing the specific academic, social, and cultural needs of unique populations.

### 207 Literacy Instruction (3) CSU

*Prerequisites: Education 1 and English 28*

*Lecture: 3 hours*

This course is designed to examine current research-supported methods and materials used in developing reading and writing skills in children from kindergarten through high school. This course will also focus on the application of literacy strategies across multiple content areas and address the needs of diverse learners using alternative or adaptive methods. The course will take a balanced approach to literacy instruction: balancing research with practical classroom application, balancing explicit instruction with authentic application, and balancing assessment and instruction.

### 208 Effective K-12 Classroom Management (3) CSU

*Prerequisite: Education 1 and English 28*

*Lecture: 3 hours*

This course will survey instructional approaches, materials, and methods for classroom management. Emphasis will be placed on management styles and the various methods associated with those styles. This course offers a holistic view beginning with a variety of methods and activities for helping teachers build positive learning environments (a community of learners), improve relations in the classroom (and broader community), and cope with challenging behaviors and special abilities. Students will explore a plethora of activities and techniques that encourage prosocial behavior and promote collaboration, teamwork, and positive teacher-student and peer relationships in the classroom. You will practice strategies for managing students' work, teaching to students' strengths, and using technology in the classroom. This course will continually challenge students to examine and modify your current instructional practices to serve all your students successfully.

### 385 Directed Study—Education (3) CSU

*Lecture: 3 hours*

This course allows students to pursue directed study in Education under the direction of a supervising instructor. Emphasis is placed on providing the students with concept information and practical experience essential for working in the educational field. Students are assigned K-12 field work experience in public or private schools, after-school programs, and other educational agencies.

### 931 Cooperative Education—Education (3) CSU

*Lecture: 3 hours*

*Note: Requires 15 to 19 hours per week; paid employment related to the occupational major and enrollment in at least 7 units (which include Co-op Ed).*

This course offers advanced supervised training in an employment area that enhances the student's educational goals.

## ELECTRONICS

### 2 Introduction to Electronics (3) CSU

*Lecture: 3 hours*

An introductory electronics course for majors and non-majors, with emphasis on hands-on activities. In addition to exploring career opportunities in the world's largest industry, electronics, students will learn to solder, read schematic drawings, identify electronic components, gates, symbols, electrical laws, numbering systems, and construct numerous electronic circuits and projects.

### 8 Electron Devices (4) CSU

*Lecture: 3 hours; Lab: 3 hours*

This course imparts knowledge of semiconductor, electron devices including diodes, transistors, silicon-controlled rectifiers (SCR), solar cells, modules and photovoltaic panels, and their application in electronic circuits such as amplifiers, switches, power supplies, oscillators, IC chips, DC/AC power control, and conversion of sunlight to usable electric power.

### 15 Survey of Computer Electronics (3) CSU

*Lecture: 2 hours; Lab: 3 hours*

This is an entry-level course in computer electronics technology to develop basic concepts of electronics. Major topics include: electricity, electrons, voltage, resistance, and current flow defined by Ohm's law, electric and magnetic energy storage in capacitive and inductive circuits, electric motors, generators, measuring instruments, and electron devices like diodes, solar cells, transistors and amplifiers.

### 41 Measurement and Testing Laboratory I (1) RPT3

*Lab: 3 hours*

This first lab course provides essential knowledge of electronic instruments, such as a digital multimeter (DMM), and how they are used to test electronic components that include resistors, potentiometers, capacitors, junction- and light-emitting diodes, NPN and PNP transistors, 555 timers, and oscillators.

### 56 Computer Circuits (3) CSU

*Corequisite: Electronics 57*

*Lecture: 3 hours*

A detailed study of computer circuits is covered and their function in microcomputer systems. Input, output, and multimedia and mass storage devices including displays, laser printers, hard disk drives, motherboard, windows operating system and memory management will be introduced. This theory course covers installation and troubleshooting of hardware and software components. In addition, this course prepares the students for the A+ Core Hardware Exam and A+ Operating System Technologies Exam for A+ Certification. No experience in electronics is assumed.

### 57 Computer Circuits Laboratory (1) CSU

*Corequisite: Electronics 56*

*Lab: 3 hours*

This laboratory course involves troubleshooting techniques of a microcomputer system in a hands-on lab environment. It includes fault isolation of problems and general repair methods of various PC components and peripherals. It also includes hardware and software and installations. Students will take a system apart and assemble it back together again.

### 111 Introduction to Computer Servicing (4) CSU

*Lecture: 3 hours; Lab: 3 hours*

This first Course on COMPUTER SERVICING imparts knowledge of computer architecture including system box, Motherboard, Processor (CPU), Hard Disk, DVD/CD, Semiconductor Memory (RAM/ROM), Expansion Slots, USB/



Parallel/Serial ports used for connecting external (peripheral) devices like mouse, Keyboard and Printers. It provides a solid foundation for students to learn and practice the basics of configuring, maintaining, upgrading and servicing of computers.

### 112 Computer Operating Systems (4) CSU

*Lecture: 3 hours; Lab: 3 hours*

This course familiarizes students with the circuitry, installation, configuration, upgrade, and troubleshooting techniques for the microcomputer system, DOS, and Windows environments. It also acquaints students with command line operations, creation and organization of files and folders for Windows operating systems (Windows NT, 2000, XP). A brief introduction to Linux is covered. It will cover other topics including home networking with shared Internet connection.

### 113 Computer Networking (4) CSU

*Lecture: 3 hours; Lab: 3 hours*

This course is designed for students who want to gain a solid understanding of a broad range of networking technologies, especially for those who wish to pursue certifications in a variety of computer networking fields, including Network+, CCNA, MCSE, and Linux+. Covers networking hardware and software components. Student should have a background in basic computer concepts. No experience in electronics is assumed, or required.

### 116 Computer A+ and Network + Certificate Exam Prep (2) CSU

*Lecture: 1 hour; Lab: 3 hours*

One of two courses on the computer hardware and operation to prepare students for Comp TIA A+ certification exam. Includes technology of desktop and portable computers, printers, and an understanding of, installing and upgrading Microsoft Windows operating systems; It covers principles of working with the Window Command Line Interface, troubleshooting and maintenance of Windows, essentials of computer security, networking, and Internet connectivity.

## ENGINEERING, GENERAL

### 101 Introduction to Science, Engineering and Technology (3) UC:CSU

*Lecture: 1 hour; Lab: 2 hours*

This course provides students with an understanding of the academic and professional attitudes, behaviors and skills necessary to enhance their chances of success as a science, engineering or technology major, and ultimately as a professional. The job functions of various engineering disciplines as well as the general definition of engineering are examined. Working effectively in teams, goal setting, time management, self-improvement, methods of learning, and developing oral communication skills are practiced. Students are introduced to the campus resources available to science, engineering and technology majors and learn how to orient themselves to the science and engineering educational system. Students have an opportunity to work collaboratively with their classmates on most of the assignments and in-class projects.

### 122 PROGRAMMING and PROBLEM-SOLVING IN MATLAB (3) CSU

*Prerequisite: Math 265*

*Lecture: 2 hours; Lab: 3 hours*

This course utilizes the MATLAB environment to provide students with a working knowledge of computer-based

problem-solving methods relevant to science and engineering. It introduces the fundamentals of procedural and object-oriented programming, numerical analysis, and data structures. Examples and assignments in the course are drawn from practical applications in engineering, physics, and mathematics.

### 131 Statics (3) CSU

*Prerequisites: Physics 37 and Math 265*

*Lecture: 2 hours; Lab 3 hours*

This is a first course in engineering mechanics. The course considers two-dimensional and three-dimensional analyses of force systems on particles and rigid bodies in equilibrium. Topics also include static analysis of trusses, beams and cables, determination of center of gravity, centroids, friction, and moments of inertia of area and mass.

### 151 Materials of Engineering (3) CSU

*Prerequisites: Chemistry 101 and Math 265*

*Lecture: 3 hours*

This course is an introduction to materials science and engineering and different types of materials used in engineering design, emphasizing the relationships between structure, properties, and processing. Topics include: atomic structure and bonding, atomic and ionic arrangements and imperfections, crystalline structures, metals, polymers, ceramics, composites including diffusion or atom and ion movements in materials, and mechanical properties and fracture including strain hardening and annealing. Fundamental properties of materials and their applications in engineering are also covered.

### 220 Electrical Circuits I (4) UC:CSU

*Prerequisites: Physics 38 and Math 275*

*Recommended: ENG GEN 102 or ENG GEN 122*

*Lecture 3 hours; Lab 3 hours*

This course covers electric circuit analysis in time and frequency domains, transient, and steady state solutions. Topics include linear circuit analysis techniques, Kirchhoff's Laws, Network Theorems, mesh and nodal analysis, OP amps and amplifiers, Thevenin/Norton equivalents circuits, natural-forced-complete response of RLC circuits, AC circuits, phasors, three phase power, and frequency response and resonance. The laboratory includes experimental verification of the laws of AC and DC circuits, Kirchhoff's laws, and Thevenin's theorem using instruments such as multimeter, oscilloscopes, and signal generators.

### 241 Strength of Materials (3) UC:CSU

*Prerequisite: ENG GEN 131*

*Lecture 2 hours; Lab 3 hours*

In this course, students learn the application of mechanics to determine the effect of forces and torques on materials. Students apply this knowledge to the design of load bearing components. The course covers the following topics: Stress, strain, axial loading, torsion, flexural stresses, transverse shear stress, horizontal shear stresses, stress transformations, Mohr's circle, pressure vessels, shear and bending moment diagrams, stresses in a beam, methods of superposition, and elastic strain energy.

## ENGINEERING GRAPHICS & DESIGN

### 101 Engineering Graphics (3) UC:CSU

*Recommended: Math 240*

This introductory course covers the fundamentals of traditional board drafting, descriptive geometry, orthographic projection, graphical communication of

technical engineering information and Computer-Aided Drafting (CAD). Topics include freehand drawing, lettering, and theory of orthographic and multi-view projections. Basic drafting skills, industry standards and technical graphics practices, and engineering scales are presented. The theory of descriptive geometry is taught including the fundamentals of auxiliary views, coordinate systems, sectioning, dimensioning, lines, planes intersections, visibility, and development. Coordinate dimensioning and geometric dimensioning and tolerancing (GD&T) subjects are covered including location tolerance, datum reference, tolerance symbols and feature control frames. An introduction to both 2-D and 3-D CAD, in two separate software packages is given. CAD instruction includes drawing set up and settings, creating templates, title blocks, layers, drawing basic geometric objects, extrusion, dimensioning and creating basic engineering drawings such as part and assembly drawings as well as orthographic multi-view drawings.

### 111 2-D Computer-Aided Drafting(3)

#### UC:CSU

*Corequisite: EGD TEK 101*

*Lecture: 2 hours; Lab 2 hours*

This course is an introductory course in Two-Dimensional Computer-Aided Drafting using AutoCAD. Students learn the basic tools to create and edit a simple drawing. Topics include object construction, object properties, layers, orthographic projections, auxiliary views, parametric tools, basic dimensioning, template building, and plotting.

### 121 3-D Computer-Aided Design with Solidworks (3) UC:CSU

*Prerequisites: EGD TEK 101*

*Lecture: 2 hours*

This is an introductory course in Three-Dimensional Computer-Aided Design and solid modeling. Students learn extrusion, revolve, sweep and loft boss, base, and cut. Other topics covered include creating assemblies and making drawing files out of the solid model or the assembly, utilizing SolidWorks 3-D software extrusion, revolve, sweep and loft boss, base, and cut. Other topics covered include creating assemblies and making drawing files out of the solid model or the assembly, utilizing SolidWorks 3-D software

## ENGLISH

### 20A College Reading Skills (3) NDA (Pass/No Pass)

*Corequisite: Reading 22*

*Recommended: English 94*

*Lecture: 3 hours*

This reading/writing course enables students to develop basic college reading and writing skills that will help them to succeed in courses that require them to interpret and write about texts. However, students are encouraged to complete English 94, Intensive Grammar, English 21, English Fundamentals, and all core English courses before they enroll in courses in other disciplines that require them to write essays and term papers. Completion of English 94, English 21, and all core English courses will help students to develop the more advanced college reading and writing skills that they need to succeed academically. This course's primary objective is to prepare students for English 21.

### 21 English Fundamentals (3) NDA (Pass/No Pass)

*Prerequisites: Developmental Communications 21 and 23 or ESL 6A and B or English 20A*

*Lecture: 3 hours*

English 21 introduces the student to basic academic reading, writing, and thinking. Students develop reading comprehension by studying shorter published essays, which then provide models of and/or subjects for their compositions. Basic grammar is covered as an essential component of the writing process.

### 28 Intermediate Reading and Composition (3) NDA

*Prerequisite: English 21*

*Lecture: 3 hours*

In this course students plan, draft, revise, and edit compositions of increasing sophistication and complexity. All writing is based on readings that challenge the student's thinking and provide an intellectual background for writing assignments. The course also advances skills in paragraph structure, sentence variety, thesis development, organization, coherence, and language conventions as well as prepares them for English 101.

### 94 Intensive Grammar Review (3) NDA

*Lecture: 3 hours*

This course offers an intensive review of the principles of standard English grammar, sentence structure, and English usage and diction. The course will cover the parts of speech, verb forms and tenses, fragments, run-ons, and other issues in standard grammar usage. Students will learn to identify errors and correct them. This course is intended for students preparing for English 28, English 31 and English 101.

### 101 College Reading and Composition I (3) UC:CSU

*IGETC Area 1A*

*CSUGE Area A2*

*Prerequisite: English 28 or 31 or 145*

*Lecture: 3 hours*

English 101 teaches freshman-level college composition and reading. Students are provided with practice in college-level compositions and engage in critical analysis of reading at higher education level. The class focus is organization and composition of longer expository essays (500-1000 words), with one or more including researched secondary sources and MLA documentation.

### 102 College Reading and Composition II (3) UC:CSU

*IGETC Area 1B, 3B*

*CSUGE Area A3, C2*

*Prerequisite: English 101*

*Lecture: 3 hours*

This course teaches critical thinking, reading, and writing skills beyond the level achieved in English 101. Emphasis is placed on developing students' analytical and inferential reasoning skills, and on expanding their strategies for argumentation, using the various genres of literature and literary criticism as subject matter. Analytic, interpretative, argumentative, and researched papers of increasing length and depth are assigned.

### 103 Composition and Critical Thinking (3) UC:CSU

*IGETC Area 1B*

*CSUGE Area A3*

*Prerequisite: English 101*

*Lecture: 3 hours*

This course is designed to further expand critical thinking, reading, and writing abilities that students developed in



English 101. Students will learn to compose effective prose in essays and other written assignments, writing a minimum of 8,000 words. Students will read, analyze, evaluate discuss and write about assigned essays and literary works, both fiction and non-fiction. Skills in locating, interpreting, and organizing pertinent information to be used in research papers will be emphasized in the course.

### 111 New Media for Writers (3) UC:CSU

*Prerequisite: English 28*

*Lecture: 3 hours*

Students in this course learn how to effectively create a presence in the web-based communities of writers and develop distinctive voices by focusing on writing original stories from the local community, including their fictional and creative works. Topics covered will include the media professions, Web credibility, online sources, blogging and podcasting, and basic multimedia design. Students will both critique and create online materials. We will use computers and readings and discussions to learn about online publishing. The class will include lectures on emerging media themes, such as the ethical and legal implications of publishing online in a 24/7 environment; the characteristics that distinguish Web sites and their stories from print and broadcast counterparts; guidelines for doing research on the Internet; and the impact of blogs, wikis and other citizen generated information. They'll also participate in a class blog (using blogger.com), learn how to create their own blogs and RSS readers, and to tweet on Twitter.

### 127 Creative Writing (3) UC:CSU RPT3

*Prerequisite: English 28 or 31*

*Lecture: 3 hours*

This course is designed for those who want to practice writing and develop a portfolio of creative writing. Students will write poems, plays, stories, and/or multi-media works and present their writing in workshops for informal discussion and evaluation by the class and instructor, and for publication in the LASC online literary journal, *The Truth*. Instruction in creative writing as well as critical reading will be provided.

### 145 Accelerated Reading, Reasoning, and Writing (3)

*Prerequisite: Placement Exam or Basic Skills 2CE, ESL 06A, ESL 06B or English 20A*

*Lecture: 3 hours*

English 145 is an accelerated course that takes the place of English 21 and English 28 and prepares the student for English 101 by increasing his/her capability to think critically and work on an academic level. In this class students plan, draft, revise, and edit compositions of increasing sophistication and complexity. Unlike English 21 and English 28, all writing is based on academic readings that challenge the student's thinking and provide an intellectual background for writing assignments. The course also advances skills in paragraph structure, basic grammar, sentence variety, thesis development, organization and coherence, as well as language conventions.

### 207 American Literature I (3) UC:CSU

*CSUGE Area C2*

*Prerequisite: English 101 and English 102*

*Lecture: 3 hours*

This course introduces American writers and writings from colonial times to 1865. Besides working with major writers, students will become acquainted with writers who suggest the diversity of subject and opinion in American literature.

### 208 American Literature II (3) CSU

*CSUGE Area C2*

*Prerequisite: English 101*

*Lecture: 3 hours*

This course is a study of selected writers in the United States from the Civil War to the present.

### 211 Fiction (3) UC:CSU

*IGETC Area*

*CSUGE Area*

*Prerequisite: English 101*

*Lecture: 3 hours*

Students read, interpret, and discuss selected short stories and novels from diverse perspectives, using literary terms and applying contemporary approaches to understanding literature.

### 212 Poetry (3) UC:CSU

*IGETC Area 3B*

*CSUGE Area C2*

*Prerequisite: English 101*

*Lecture: 3 hours*

Reading, discussion, and analysis, oral and written, of selected poetry acquaint the student with this genre.

### 213 Dramatic Literature (3) UC:CSU

*IGETC Area 3B*

*CSUGE Area C2*

*Prerequisite: English 101*

*Lecture: 3 hours*

Reading, discussion, and analysis, oral and written, of selected dramatic works acquaint the student with this genre.

### 215 Shakespeare I (3) UC:CSU

*IGETC Area 3B*

*CSUGE Area C2*

*Prerequisite: English 101*

*Lecture: 3 hours*

This course introduces students to Shakespeare's writing through a study of selected plays and sonnets with some examination of Shakespeare's life and times. The course emphasizes reading, writing, class discussion, analysis of Shakespeare's texts, and student research.

### 223 Creative Nonfiction (3) CSU

*Lecture: 3 hours*

In this course, students will read and write different genres of Creative Nonfiction, specifically reportage (biography, profiles, editorials, cultural criticism, etc.) and personal narrative (autobiography, travel writing, diary, meditative, etc.). During the semester, students will learn to recognize and explore the features of creative nonfiction, and through the writing process, discover how to apply creative writing techniques to nonfiction subjects in both traditional and new media formats. At the end of the course, students will have produced a portfolio of work and submitted an article for publication.

### 234 African-American Literature I (3) UC:CSU

*IGETC Area 3B*

*CSUGE Area C2*

*Prerequisite: English 101*

*Lecture: 3 hours*

This course surveys African American literature, which documents and interprets the Black experience in the United States. The course offers both chronological and thematic coverage of literary content, and identifies significant authors and their work in the various literary genres, including autobiography and the essay. The examines the relationship of this literature to the individual struggles of Black Americans.

**240 Literature and the Motion Picture I (3)  
CSU**

*Prerequisite: English 101*  
*Recommended: English 102*

This course examines the comparative arts of literature and the motion picture. Includes readings of literary works, both classic and modern, screenings of film versions based upon these literary sources, discussion, and writing of critical papers, and analysis of film using the tools of literary analysis.

**ENGLISH AS A SECOND  
LANGUAGE (NONCREDIT)  
(ESL NC)****40CE Writing/Grammar/Reading/  
Listening and Speaking I (0)**

*Lecture: 10 hours*

This competency-based, open-entry ESL course teaches beginning English speaking, listening, reading, and writing skills to non-native speakers of English. The focus of instruction is on the speaking and understanding necessary to satisfy routine social demands and limited work requirements. Students learn to comprehend frequently used words in context, use learned phrases and sentences to communicate needs, understand basic grammar structures and read simplified material.

**41CE Writing/Grammar/Reading/  
Listening and Speaking II (0)**

*Lecture: 10 hours*

This competency-based, open-entry ESL course teaches high beginning English speaking, listening, comprehension, reading, and writing skills to non-native speakers of English. This course develops communicative competence in listening, speaking, reading and writing skills in English. To develop these skills, a sequence of grammatical structures is integrated in the context of everyday situations.

**42CE Writing/Grammar/Reading/  
Listening and Speaking III (0)**

*Lecture: 5 hours*

This open-entry, competency-based, course is designed to develop communicative competence in listening, speaking, reading, and writing for the immediate needs of adult non-native English learners at the intermediate low level.

**43CE Writing/Grammar/Reading/  
Listening and Speaking IV(0)**

*Lecture: 5 hours*

ESL 043CE prepares non-native speakers of English to enroll in credit academic and/or vocational courses. This course emphasizes fluency and communication by integrating language functions and forms with appropriate information sources, skills and topics. This course provides development of reading and writing skills through the writing process.

**ESL AND CIVICS  
(NONCREDIT) (ESLCVCS)****10CE ESL and Civics 1 (0)**

*Lecture: 1 hour*

This introductory open-entry course will provide the content and the oral/aural skills practice necessary to begin the

process of becoming a United States citizen. The major focus is on developing listening, speaking, reading and writing skills.

**11CE ESL and Civics 2 (0)**

*Lecture: 1 hour*

This open-entry course will provide the instruction and practice of the elements of English pronunciation which have the greatest impact on speaking clearly. The focus of this class is the oral Citizenship interview

**12CE ESL and Civics 3 (0)**

*Lecture: 1 hour*

This competency-based, open-entry citizenship course will provide the content and the oral/aural skills practice necessary to complete the process of becoming a United States citizen. Topics include United States history, government and civics information. Students will be introduced to the content necessary in order to have a functioning understanding of the English Language.

**13CE ESL and Civics 4 (0)**

*Lecture: 3 hours*

This class is designed to introduce the newly arrived immigrant students to the American educational system. Students will learn vocabulary and grammar forms and increase their knowledge of their rights and responsibilities and educational opportunities. They will also learn to dialogue effectively in the educational setting in order to advocate for themselves and their children.

**14CE ESL and Civics 5 (0)**

*Lecture: 3 hours*

This class is designed to introduce the newly arrived immigrant students to the American banking and financial systems in order to begin to develop financial literacy and complete necessary forms. Students will be introduced to consumer laws and protections. Students will also be introduced to vocabulary and grammar to begin dialoguing within the banking and financial settings.

**015CE ESL and Civics 6 (0)**

*Lecture: 3 hours*

This open-entry course will introduce the integrated topics of Civics and Citizenship preparation. Students will prepare for the Citizenship test and interview. They will also learn skills to assist them in their immersion into a predominantly English speaking society.

**ENGLISH AS A SECOND  
LANGUAGE (E.S.L.) (CREDIT)**

English as a Second Language classes are for students whose first language is not English

**ESL 3A College English as a Second  
Language III: Writing/Grammar (6) NDA**

*Prerequisite: Placement Exam*

*Lecture: 6 hours*

In this course for non-native speakers of English, emphasis is placed on vocabulary, grammar, and guided paragraph writing. Related reading activities provide models of writing and present new vocabulary in context.

**ESL 3B College English as a Second  
Language III: Reading/ Vocabulary (3)  
NDA**



*Prerequisite: ESL 2A and ESL 2B*

*Lecture: 3 hours*

In this course for non-native speakers of English, emphasis is placed on building reading comprehension skills by identifying the main idea and details, drawing conclusions, inferring, and sequencing. Students will build vocabulary using word attack skills and learning new sight words and idioms.

### **ESL 3C College English as a Second Language III: Listening/Speaking (3) NDA**

*Prerequisite: ESL 2A and ESL 2B*

*Lecture: 3 hours.*

In this course for non-native speakers of English, emphasis is placed on listening and speaking English at a normal rate of speech. Students will develop listening comprehension skills and will be able to orally respond with appropriate phrases, short answers, and simple sentences in structured communication situations.

### **ESL 4A College English as a Second Language IV: Writing/Grammar (3) NDA**

*Prerequisite: ESL 3A*

*Lecture: 6 hours.*

In this course for non-native speakers of English, emphasis is placed on development of paragraph writing using the writing process. Reading activities provide models of writing and present new vocabulary in context

### **ESL 4B College English as a Second Language IV: Reading/ Vocabulary (3) NDA**

*Prerequisite: ESL 3B*

*Lecture: 3 hours.*

In this course for non-native speakers of English, emphasis is placed on development of high intermediate reading and vocabulary building skills. Students will build reading comprehension using pre- reading techniques, skimming to identify the main idea of individual paragraphs,

### **ESL 4C College English as a Second Language IV: Listening/Speaking (3) NDA**

*Prerequisite: ESL 3C*

*Lecture: 3 hours.*

In this course for non-native speakers of English, emphasis is placed on development of intermediate listening and speaking of English skills. Students will be able to orally respond appropriately and with increasing fluency in structured communication situations.

### **ESL 5A College English as a Second Language V: Writing/Grammar (3) NDA UC:CSU**

*Prerequisite: ESL 4A or Placement Exam*

*Lecture: 6 hours.*

In this course for non-native speakers of English, emphasis is placed on development of high intermediate reading and vocabulary building skills.

### **ESL 5B College English as a Second Language V: Reading/ Vocabulary (3) NDA CSU**

*Prerequisite: ESL 4B or Placement Exam*

*Lecture: 3 hours.*

In this course for non-native speakers of English, emphasis is placed on development of high intermediate reading and

vocabulary building skills. Students will build reading comprehension using pre- reading techniques, skimming to identify the main idea of individual paragraphs,

### **ESL 5C College English as a Second Language V: Listening and Speaking (3) CSU**

*Prerequisite: ESL 4C*

*Lecture: 3 hours*

In this course for non-native speakers of English, emphasis is placed on further development of listening and speaking skills of English. Students will improve listening comprehension skills and will be able to orally respond with fluency in conversational situations, discussion, and oral presentations. They will become familiar with idiomatic expressions.

### **ESL 6A College English as a Second Language VI: Writing/Grammar (3) NDA UC:CSU**

*Prerequisite: ESL 5A or Placement Exam*

*Lecture: 6 hours.*

In this course for non-native speakers of English, emphasis is placed on high intermediate to advanced development of essay writing using the writing process. This course provides review of fundamental skills in grammar, sentence building and practice in critical thinking.

### **ESL 6B College English as a Second Language VI: Reading/ Vocabulary (3) NDA CSU**

*Prerequisite: ESL 5B or Placement Exam*

*Lecture: 3 hours.*

In this course for non-native speakers of English, emphasis is placed on development of high intermediate to advanced reading and vocabulary building skills.

### **ESL 6C College English as a Second Language VI: Listening and Speaking (3) CSU**

*Prerequisite: ESL 5C*

*Lecture: 3 hours*

In this course for non-native speakers of English, emphasis is placed on further advancement of skills based on listening to spoken and recorded presentations. Students will deliver both prepared and impromptu speeches, incorporating advanced grammar and sentence structure. They will analyze and evaluate oral presentations.

### **ESL 83 College Conversational English as a Second Language (3)**

*Lecture: 3 hours*

Intended for students whose mother tongue is not English, this course emphasizes basic language acquisition skills, including intonation patterns, American idioms, sentence patterns, grammar check for language correctness, guided writing, and conversation.

## **ENVIRONMENTAL SCIENCE**

### **1 The Human Environment: Physical Processes (3) UC:CSU**

*IGETC Area 5A*

*CSUGE Area B1*

*Lecture: 3 hours*

This course introduces students to the physical processes that govern our life support systems and the social, political

and economic factors that impact them. The basic science required to understand how our environmental systems work is presented. Topics discussed include the atmosphere, soils and agriculture, water resources and water pollution, sources of pollution and management of wastes, energy supply and usage, and alternative energy sources. Impacts of man's activities on environmental systems are presented and discussed. Finally, potential solutions to reduce or eliminate these impacts are described.

## 2 The Human Environment: Biological Processes (3) UC:CSU

IGETC Area 5B  
CSUGE Area B2, E  
Lecture: 3 hours

This course introduces students to the biological aspects of our environmental systems. Study will focus on our large-scale systems including populations and ecosystems and small-scale issues such as nutrition and toxicity. A portion of the course will be dedicated to examining the ability of species to adapt: leading to issues such as pesticide and antibiotic resistance. Global population will be examined through the lens of population dynamics. These topics will form a foundation for discussing the dynamic interplay between ecosystems, populations and economics. Upon completion of the course, students will develop an appreciation of the problems facing humans as we attempt to set environmentally meaningful standards for toxins and how important concepts such as nutrition, toxicity, birth defects and cancer rates relate to our environmental life support systems.

## 23 Pollution Prevention And Waste Minimization (3) CSU

Lecture: 3 hours

This course provides an introduction to the principles of pollution prevention and waste minimization. Students will be introduced to the federal and state of California laws, and concepts of sustainability and resources recovery. Quantities and types of wastes generated in the United States and methods of managing the wastes generated (advantages and disadvantages) will be covered, including landfill disposal, materials recovery and incineration. Federal, state and local programs to prevent, reduce and recycle wastes will be introduced and discussed. Students will apply the principles presented in class to develop a pollution prevention/waste minimization plan.

## 25 Principles of Wastewater Technology (3) CSU

Lecture: 3 hours

This course covers the basic principles of wastewater technology. Topics covered include: regulatory framework; wastewater collection systems; industrial and municipal wastewater characteristics; primary, secondary and tertiary treatment processes; solids management and disinfection processes; and wastewater reuse options.

## ENVIRONMENTAL STUDIES

### 101 Introduction to Environmental Studies (3) UC:CSU

IGETC Area 4G  
CSUGE Area D7  
Lecture: 3 hours

This course provides an introduction to the principles of sustainability. It provides an interdisciplinary overview of the local and global impacts of humans on the natural environment. Topics include the growth and geographic

expansion of human population, the transformation of earth's ecosystems by humans, exploitation of natural resources, and sustainable practices and policies. The course focuses on the critical analysis of current environmental problems and the evaluation of alternatives and solutions that contribute to a sustainable world.

## FAMILY AND COMSUMER STUDIES

### 21 Nutrition (3) CSU

CSUGE Area E  
Lecture: 3 hours

This course examines the basic principles of human nutrition and their relationships to optimum health. Food sources of nutrients, scientific concepts relating to the functions of nutrients, and current nutritional issues are emphasized. Nutritional needs during the various stages of the life cycle from prenatal to adult are studied. Student food intake is evaluated using a computerized diet analysis. Students learn the scientific concepts of Nutrition in a lecture interactive format evaluating how lifestyle, diet, food/nutrition/ nutrient excess and deficiencies; phytochemicals; food safety; food technology affect diseases and assessment of nutrition in human development from conception through maturity. Personal dietary assessment, synthesizing data from computerized dietary program and family tree, appraises nutritional disease risk factors. Students evaluate excesses and deficiencies and construct practices that establish and maintain a healthy lifestyle and result in a healthier mind, healthier nutritional eating practices, enhancing the spirit and nourishing the body.

## FINANCE

### 1 Principles of Finance (3) CSU

Lecture: 3 hours

This course is designed to cover the markets in which funds are traded, the financial institutions that participate in and aid the flow of funds, and the principles of financial management that guide the participants in making sound decisions.

## FRENCH

### 1 Elementary French I (5) UC:CSU

IGETC Area 6A  
CSUGE Area C2  
Lecture: 5 hours

This course stresses the mastery of fundamentals of French pronunciation and structure. Emphasis is placed upon developing the student's ability to speak, understand, read and write simple French, paying special attention to practical vocabulary and idiomatic expressions. In addition, the student is introduced to some important aspects of French civilization and culture through simple readings and visual aids. *Note: Corresponds to the first two years of high school study.*

### 2 Elementary French II (5) UC:CSU

IGETC Area 3B, 6A  
CSUGE Area C2  
Prerequisite: French 1  
Lecture: 5 hours

This course is a continuation of French I, with an increased emphasis on conversation. It includes the study of the past, and future verb tenses, of the passé composé, the imperfect, and the conditional, also of the subjunctive mood. Readings and vocabulary on daily life in France and Francophone nations are featured, also comparisons with





American culture.

## GEOGRAPHY

### 1 Physical Geography (3) UC:CSU

*IGETC Area 5A*

*CSUGE Area B1*

*Lecture: 3 hours*

This course explores the physical elements of geography. Topics include the basic characteristics of the physical environment, utilization of maps, elements of weather and climate, the interrelationship of climate, vegetation, and soils, the spatial distribution of landforms of the surface of the earth, plate tectonics, weathering, karst topography, mass wasting, and the impact of streams, wind, glaciers, and ocean processes on earth materials.

### 2 Cultural Elements of Geography (3) UC:CSU

*IGETC Area 4E*

*CSUGE Area D5*

*Lecture: 3 hours*

This course explores the cultural elements of geography and focuses on the basic characteristics of the cultural environment and how people impact planet earth. Topics include utilization of maps, spatial distribution of populations and migration patterns, cultural traditions, dispersion of language, religion, and ethnicity, political structure and urban patterns, development of agriculture, distribution of industry, and resource utilization and green technology.

### 7 World Regional Geography (3) CSU

*Lecture: 3 hours*

This course will survey the world's cultural regions and nations as interpreted by geographers, including physical, cultural, and economic features. The course will emphasize spatial and historical influences on population growth, transportation networks, natural environments, and significant features of regions.

### 14 Geography of California (3) CSU

*CSUGE Area D5*

*Lecture: 3 hours*

This course surveys the physical and cultural landscapes of California with emphasis on human-environment interaction and the natural, socio-political, economic and demographic forces that have shaped the state. The course deals with the history of the state, settlement and land-use patterns, economic activities, resource use, transportation and trade, as well as California's role in the new global economy. The political, economic, environmental and demographic challenges facing the state are also discussed. Optional field trips will be offered.

### 15 Physical Geography Laboratory (2) UC:CSU

*Prerequisite: Geography 1*

*Lecture: 1 hour; Lab: 2 hours*

Provides hands-on exercise in topics covered in the Physical Geography (Geog 1) course. This laboratory course deals with skills of collecting, analyzing, and displaying of geographic data, with a specific reference to Earth's energy balance, weather and climate, vegetation, tectonic processes, landforms, and natural hazards. Students use both analogue maps and digital media (GIS, GPS, satellite images, and Internet maps).

### 25 Introduction to Geographic Information Systems and Laboratory (4) CSU

*Lecture: 2 hours; Lab 4 hours*

Geographic Information Systems (GIS) describe the specific software and set of techniques designed to manipulate, interpret and display geographic data. This course examines the basic principles and methods of GIS, including: computer representation of geographic data, map projections, coordinate systems, vector and raster data models, spatial analysis, and effective map design. In the laboratory students acquire hands-on experience with geospatial concepts, GIS functionalities, and mapping techniques.

## GEOLOGY

### 1 Physical Geology (3) UC:CSU

*IGETC Area 5A*

*CSUGE Area B1*

*Lecture: 3 hours*

This course offers an introductory study of the earth, including discussion of minerals and rocks and how they form. Earth processes, such as volcanic activity, weathering, earthquakes, plate tectonics and mountain building are covered. The course examines features of the earth, such as rivers, deserts, glaciers, shorelines, and the ocean floor. Geologic time and earth history are also discussed.

### 2 Earth History (2) UC:CSU

*Lecture: 3 hours*

Students receive an introduction to the geological history of Earth and its inhabitants, with emphasis on the evolution of life and landforms of North America. Topics include how Earth processes produce and alter landforms, climate, and energy and water resources on which humans depend; significant tectonic events, such as mountain building episodes; and the evolutionary history of life on Earth, including plants, fish, dinosaurs, mammals, and humans. Multimedia presentations are used throughout the course. Field trips will be taken.

### 6 Physical Geology Laboratory (2) UC:CSU

*IGETC Area 5C*

*CSUGE Area B3*

*Corequisite: Geology 1*

*Lecture: 1 hour; Lab: 2 hours*

This course is the laboratory for Geology 1. It provides a hands-on investigation in greater depth of topics covered in Geology 1, such as topography, minerals, rocks, earthquakes, plate tectonics, and geologic time.

### 7 Earth History Laboratory (2) UC:CSU

*Corequisite: Geology 2*

*Lecture: 1 hour; Lab: 2 hours*

This is a supplemental laboratory course for Geology 2, intended to teach the scientific methods of reasoning and to give the student an acquaintance with the fundamental principles of historical geology. Laboratory exercises will examine the history of the earth from its origin to the present as interpreted from the fossil record and radiometric dating techniques. Also included will be the evolutionary study of fossils and study of rock types and ancient landforms. This course will include methods used to determine events in Earth history and reconstruct past environmental conditions. Field trips may be taken. Strongly recommended for the student who is enrolled in or has completed Geology 2.

## HEALTH

### 2 Health and Fitness (3) CSU

*CSUGE Area E*

*Lecture 3 hours*

This course promotes healthy physical and psychological lifestyles, with emphasis on disease prevention, including violence/abuse, nutrition, sexuality, reproduction, drugs,

alcohol, tobacco, aging, stress management, and weight control. The physical fitness segment emphasizes individual improvement utilizing aerobic, flexibility, and strengthening activities.

## 8 Women's Health (3) CSU

CSUGE Area E  
Lecture 3 hours

This course comprehensively reviews important issues related to women of all diverse backgrounds. This course designs practical approaches to understanding the health of women in relationship to physiological and psychological aspects of nutrition, mental health, exercise, hygiene, cardiovascular disease, cancer, sexuality, reproduction, drugs, and other diseases common to women.

## 11 Principles of Healthful Living (3)

UC:CSU  
CSUGE Area E  
Lecture 3 hours

This course offers concepts to use as guidelines for self-directed responsible living. Health topics cover emotional and mental health, nutrition and obesity, drug abuse, cardiovascular fitness, chronic and communicable diseases, reproduction, consumerism, environmental health, and death/dying.

## 12 Safety Education and First Aid (3)

UC:CSU  
Lecture: 3 hours

This course provides instruction in the Emergency Response System, creation of an emergency action plan, and assessment and immediate treatment given to a person who has been injured or has suddenly taken ill. Legal considerations and lifesaving procedures (e.g., use of automated external defibrillators and CPR for infants, children and adults) are covered. Upon successful completion of the course, students are eligible for certification in First Aid and CPR by the American Red Cross.

## 21 Human Sexuality (3) UC:CSU

CSUGE Area D0, D7,E  
Lecture: 3 hours

This course provides a comprehensive introduction to the cultural, behavioral, biological and psychosocial aspects of human sexuality. Topics presented include acquired immune deficiency syndrome and other sexually transmitted diseases, as well as sexual variance and dysfunction, and sexuality throughout the human life cycle.

## HEALTH OCCUPATIONS

### 62 Skill Set for the Health Care Professional (2)

Recommended: English 21 and Math 105  
Lecture: 1 hours; Lab: 3 hours

Health Occupations 62 is an introduction of the concepts and skills that serve as a foundation for the health care professions. Topics include hygiene and safety, infection control, basic client monitoring and basic first aid, therapeutic communication and basic health documentation.

### 63 Basic Medical Terminology, Pathophysiology and Pharmacology (2)

Recommended: English 21 and Math 105  
Lecture: 2 hours

This basic medical language course will discuss common diseases and injuries and their pharmacological treatment using medical terminology in English and Spanish, when appropriate.

### 64 Cultural and Legal Topics for Health Care Professionals (1)

Recommended: English 21 and Math 105  
Lecture: 1 hour

Health Occupations 64 provides an overview of the concepts of health and illness, cultural diversity and legal issues that affect the health care professional .

### 65 Fundamentals for the Health Care Professional (2.5)

Recommended: English 21 and Math 105  
Lecture: 2.5 hours

Health Occupations 65 explores career options in the health care industry, healthy behavior for health care workers, work ethics, professional resumes and interviewing skills and personality traits of a health care professional. There will be an externship during which area employers will introduce students to direct and indirect patient care opportunities.

## HISTORY

### 1 Introduction to Western Civilization I (3)

UC:CSU  
IGETC Area 3B, 4F  
CSUGE Area C2, D6  
Lecture: 3 hours

This course covers the political, economic, social, religious, and intellectual activities of Western civilization from early man through the great cultures of the Ancient Middle East, Egypt, Greece, Rome, Middle Ages, Renaissance, Reformation, and the emergence of the great modern nations of today. Emphasis is placed on changing structures in class, race, gender, and power relationships.

### 2 Introduction to Western Civilization II (3)

UC:CSU  
IGETC Area 3B, 4F  
CSUGE Area C2, D6  
Lecture: 3 hours

This course is a continuation of History 1 and covers the development of western civilization from the beginning of the Seventeenth Century to the present time. It provides a knowledge of the nations of the modern world and their relationship with one another including the relationship between development and underdevelopment in the industrial era.

### 3 History of England and Great Britain I (3)

UC:CSU  
Lecture: 3 hours

This course surveys the political, economic, and cultural development of the British Isles and the Empire from the earliest times to the eve of the American Revolution.

### 5 History of the Americas I (3) UC:CSU

IGETC Area 3B, 4F  
CSUGE Area D6  
Lecture: 3 hours

This course will examine the historical development of the Western Hemisphere with special emphasis on Central and South America from the early colonial era through the time of the U.S. Civil War and Reconstruction. The course will



analyze the indigenous cultures of the Western Hemisphere before interaction with other continents such as Europe, Africa, and Asia. Included topics are the exploration, imperial rivalries, colonial settlement and growth phases, and the American Revolution and its effect on the entire hemisphere. Also covered are responses to the Constitution of the United States of America, the effect of the latter on the political philosophies, political institutions, laws and amendment interpretations, the rights and obligations of citizens of Central and South America, the role of major ethnic and social groups, and the continuity of the Pan-American experience. Also included are an examination of geography and the development of federal, state, and local governments of many nations within the Western Hemisphere. Integrated learning strands include an overview of Dutch, British, Portuguese, African and Spanish impact on the political, social, and economic lives of indigenous societies.

### 11 Political and Social History of the United States I (3) UC:CSU

*IGETC Area 3B, 4F*  
*CSUGE Area D6, D8*  
*Lecture: 3 hours*

This is a survey of the political, social, economic, and constitutional history of the United States from its beginnings through the Civil War; a history of the United States up to the year 1865. The course covers the chronology of pre-colonial and colonial North America, the birth and early development of the United States to 1865, and is designed to present ideas, events, people, and forces that have shaped the nation and significantly contributed to the foundations of the present.

### 12 Political and Social History of the United States II (3) UC:CSU

*IGETC Area 3B, 4F*  
*CSUGE Area D6, D8*  
*Lecture: 3 hours*

This is a survey of the political, social, economic, and constitutional history of the United States from the Reconstruction Era to the present; U.S. history since 1865. The course covers the chronology of the nation from the second half of the nineteenth century to the present and is designed to present ideas, events, people, and forces that have shaped the United States and significantly contributed to the foundations of the present.

### 37 History of African Civilization (3) CSU

*Lecture: 3 hours*

This course covers the political, economic, social, religious, and intellectual activities of the African civilization. It traces the influence of Africa and its peoples in the Caribbean area and in Brazil. Forms of government, mores, and folk ways are considered.

### 41 The African-American in the History of the United States I (3) UC:CSU

*IGETC Area 4F*  
*CSUGE Area D3, D6*  
*Lecture: 3 hours*

This course will examine the historical development of the United States of America from the early colonial era through the Civil War and Reconstruction with special emphasis on the contributions of African Americans. The course will analyze the Constitution of the United States of America, political philosophies, political institutions, amendments and interpretations, the rights and obligations of citizens, the role of major ethnic and social groups, and the continuity of the American experience, geography, federal, state, and local governments. Integrated learning strands include an overview of West African societies; Africans in colonial America; The

“Peculiar Institution”, Abolition, the Civil War, Westward Expansion, Emancipation, and Reconstruction.

### 42 The African-American in the History of the United States II (3) UC:CSU

*IGETC Area 4F*  
*CSUGE Area D3, D6*  
*Lecture: 3 hours*

This course will examine the historical development of the United States of America from the end of the Civil War and Reconstruction to the present, with special emphasis on the contributions of the African Americans. The course will review changes in the Constitution of the United States, amendments and interpretations, the rights and obligations of citizens, present day relationships between state, local and federal governments, historical, geographical, intellectual, cultural, economic, political and social interaction between major ethnic groups in the United States. Topics include segregation, Southern politics and culture, its Northern counterpart, WWI, WWII, diplomatic developments, Vietnam, modern industrial structure, economic growth and urban demographic patterns.

### 43 The Mexican-American in the History of the United States I (3) UC:CSU

*IGETC Area 4F*  
*CSUGE Area D3, D6*  
*Lecture: 3 hours*

This course traces the historical evolution of the Mexican and Mexican-American people and their institutions within the context of United States history. It surveys the contributions of the Mexican people to the US with emphasis on the Southwest.

### 52 The Role of Women in the History of the United States (3) UC:CSU

*IGETC Area 4D, 4F*  
*CSUGE Area D4, D6*  
*Lecture: 3 hours*

This course will examine the historical development of the United States of America from the end of the colonial period to the present with special emphasis on the contributions of women. The course will review changes in feminism, gender and the Constitution of the United States, i.e., the 19<sup>th</sup> amendment, the Suffragettes, their relationship to abolitionism and other feminist campaigns. This course includes an analysis of the social and economic disparity between women and men, women's roles within state, local and federal governments, their intellectual, cultural, and social interaction in the larger society and explores the issues of women in major ethnic groups in the United States, and interaction of women within and outside each group. Topics include colonial women, frontier women, progressivism, unions, birth control, discrimination, sectional conflict from the perspective of women, WWII, “Rosie”, Vietnam, the modern industrial complex, globalization, and urban demographic patterns as they relate to the lives of women.

## HUMANITIES

### 1 Cultural Patterns of Western Civilization (3) UC:CSU

*IGETC Area 3B*  
*CSUGE Area C2*  
*Lecture: 3 hours*

An interdisciplinary study is made of art, music, and literature to reveal general traits of Western Civilization. Emphasis is placed on objective analysis and comparison of selected works from all of the arts.

**2 Studies in Selected Cultures (3) UC:CSU**

CSUGE Area C2

Lecture: 3 hours

Art, music, and literature are studied as they interrelate to reveal non-Western views of philosophy, science, religion and the self. Emphasis is placed on Japan, China, the Middle East (Egypt), and Sub-Saharan Africa (Ghana, Kenya).

**6 Great People, Great Ages (3) UC:CSU**

CSUGE Area C2, D6

Lecture: 3 hours

This course provides a study of the artistic contributions of selected individuals from ancient times to the present. An appreciation of their ideas and forces which have shaped our cultural heritage will also be studied (from Imhotep to Toni Morrison).

**31 People in Contemporary Society (3) UC:CSU**

IGETC Area 3B

CSUGE Area C2

Lecture: 3 hours

Humanities 31 is a college level course which surveys the cultural heritage of Western civilization from the 17th Century to the present including artistic, literary, philosophical, and religious traditions, as it analyzes the changing relationship with varied visual materials.

**INDUSTRIAL TECHNOLOGY****103 Technical Writing and Communication (2) CSU**

Lecture: 1 hour; Lab: 2 hours

This course introduces the principles and practices of writing a range of technical documents including emails, letters, technical evaluations and reports, and academic and scientific papers used in the engineering, science, and technology fields. The use of graphical information such as tables and charts are covered as well as technical resumes, letters, and instruction and operation manuals.

**INTERNATIONAL BUSINESS****601 Introduction to Global Trade and Logistics (3)**

Lecture: 3 hours

This course provides an overview of the global marketplace with emphasis on the impact and dynamics of socio-cultural, demographic, economic, technological, political, and legal factors in the foreign trade environment. Topics include patterns of world trade, supply chain and logistics, internationalization of the firm, and operating procedures of the multinational enterprise.

**602 Global Economics (3) CSU**

Lecture: 3 hours

This course provides the students with an understanding of global economy and internationalization of business. It covers international economics, finance, and trade as a natural consequence of the theory of Comparative Advantage. Includes multinational enterprises, legal, political, and socio-cultural issues, survey of global strategic management. This course will give the students an understanding of global economics and helps them understand the complexities of operating an import or export business.

**603 Cross Cultural Management (3) CSU**

Lecture: 3 hours

Students examine the role of culture in the operations of an organization. They will explore ways to identify cultural differences and culture's impact on strategic approach, organizational structure, and different approaches to human resources. Focus will be the new approaches toward creating Global Managers and team building across cultures.

**604 Global Marketing & Trade Agreements (3)**

Lecture: 3 hours

This Course considers the required adjustments in marketing strategy to remain competitive in a global environment. Topics include trade policy basics, tariffs and non-tariff barriers, safeguards, voluntary restraints, dumping, subsidies and strategic trade theory, agricultural trade, developing country rules, regionalism, and services.

**605 Contemporary Issues in Global Trade & Logistics (3)**

Lecture: 3 hours

Deals with selected topics of current importance in global business. The topics may vary from semester to semester and selected from research projects, comparative cross-cultural behaviors and business practices, global distribution and transportation, regional trade and competition, and marketing opportunities in the European and Latin American communities.

**606 Principles of Import (3)**

Lecture: 3 hours

In this course the student learns how to identify, define, and explain the United States regulatory agencies requirements to import to the United States. Emphasis will be placed on how to determine what duties commodities might be subject to and how to prepare and present to the Bureau of Customs the shipment and its document.

**609 Internet Fundamentals and E-Business (3) CSU**

Lecture: 3 hours

This course provides students with the skills required to manage electronic business, commerce, government information systems, and technology. The course will also emphasize the role of global strategic information systems as applied to problem solving and current transportation and customs software. In addition, students will conduct international market research, create an e-commerce web site, and establish an entrepreneurial venture.

**610 International Business (CSU)**

Lecture: 3 hours

Students will learn how global marketing works beyond our borders as well as how to construct a sound plan for identifying and delivering a product made in the US to selected markets. It examines the challenges and rewards found in international marketing, which is now the center of growth and opportunity for U. S. enterprise. During the process of plan development, students will gain knowledge in the unique issues of delivering products and services abroad including: import taxes, letters of credit, shipping agreements, free trade zones, regulations on media and advertising and trade organizations and resources.

**611 Customhouse Brokerage: Payment Instruments and Procedures I (3) CSU**



*Lecture: 3 hours*

The student learns how to arrange and receive payment for merchandise shipped from one country to another. Topics covered include how to prepare and fill out documents. Also included is information regarding credit and political risk insurance.

### **612 Supply Chain Management: Transport Systems (3) CSU**

*Lecture: 3 hours*

This course examines the global transport systems used in importing and exporting. Emphasis is given to the role of ocean, air, land, and multimodal transport infrastructures as key components of international supply chain management operations. Supporting international trade topics include commercial terms of trade, commercial and transportation documents, insurance, packaging for export, logistics infrastructure and security, and United States Customs clearance.

## **JOURNALISM**

### **101 Collecting and Writing News (3) CSU**

*Prerequisite: English 21 or English 28 or 31 or 145*

*Lecture: 3 hours*

This introductory course stresses instruction and practice in news gathering and news writing. Extensive practical writing experience is geared to the campus newspaper. It also includes a study of newspaper, radio, television and online news. Adherence to professional writing style and legal and ethical aspects of the profession are included.

### **105 Mass Communications (3) UC:CSU**

*Recommended: English 28 or 31*

*Lecture: 3 hours*

This course surveys America's mass communications systems and how they affect human behavior in relation to social, political, and economic institutions. Newspapers, magazines, television, advertising, public relations, radio, records, and movies and how they affect us as members of society will be studied. This history, sociology, operation, regulation by society, and financing will be included. Students will gain an understanding of the ways media have been and are used to influence, manipulate, and reflect the society and special interest groups within the society and they will become more critical media consumers.

### **123 Convergent Journalism (3) CSU**

*Prerequisite: Journalism 101*

*Recommended: Media Arts 100*

*Lecture: 3 hours*

Convergent Journalism—the convergence of broadcast, print and web formats—provides an overview of new journalism, supplying a foundation for skills in non-fiction composition using multimedia, critical thinking and new media literacy. Students explore writing for the internet, audio/video podcasting, interactive multimedia, digital storytelling, and nonfiction composition—and they contribute regularly to the online campus newspaper, The Word.

### **217 Publication Laboratory (2)**

*Prerequisite: Journalism 101*

*Co-requisite: Journalism 219*

Student reporters, editors, photographers and other visual student journalists learn newspaper production techniques through the publication of the campus newspaper and website, as well as other student-produced publications. Reporters will focus on basic reporting and writing for the campus newspaper and website and other student-run

publications, while photographers focus on gathering images for publications. Other visual journalists will focus on beginning layout and design or cartooning and illustration.

### **219 Techniques for Staff Writers (1) CSU**

*Prerequisite: Journalism 101*

*Corequisite: Journalism 217*

*Recommended: English 21, 28, 101*

Students analyze editorial problems and write editorials for the College newspaper. Formulation of editorial policy, first-person commentaries, third-person commentaries, editorial cartoons, letters to the editor, corrections/clarifications, encouraging reader participation, ethics, and writing skills are emphasized. This course is designed for College newspaper editors.

## **KINESIOLOGY**

### **180 Marathon Training Course for Run/Walk (1.5) CSU**

*Lecture: 0.5; Activity: 3.5 hours*

Students utilize and understand aerobic and anaerobic energy systems and when each is used. Students develop an understanding of cardiovascular endurance and specificity of training for marathons using a variety of tempo run/walks. Race analysis and race psychology are also explained along with proper hydration and nutrition.

### **201 Swimming Skills (1) UC:CSU RPT 3**

*CSUGE Area E*

*Activity: 2 hours*

Students learn and refine their swimming skills for each stroke, including kicking, arm stroke, proper breathing techniques, body position, diving, and rhythm of stroke. The student will also learn water safety skills.

### **217 Self-Defense Skills (1) UC:CSU**

*CSUGE Area E*

*Lecture: 0.5 hour; Activity: 1.5 hours*

This course covers self-defense skills, safety precautions, and the promotion of mental and physical wellbeing. Defense against rape and other physical attacks are also demonstrated.

### **217-2 Self-Defense Skills II (1) CSU**

*Prerequisite: Kinesiology 217 or 217-1*

*Lecture: 0.5 hour; Activity: 1.5 hours*

This course instructs the student in self-defense and personal safety skills for men and women against deadly dangerous and other physical attacks at a beginning karate and martial arts skills level. The course includes discussion of safe defense and protection strategies and the promotion of mental and physical well-being.

### **229 Body Conditioning Skills (1) UC:CSU RPT 3**

*Activity: 2 hours*

This course uses a variety of aerobic and anaerobic exercises to help the student achieve fitness and establish a workout program they can use for the rest of their life. Exercises are drawn from a number of different sources such as aerobics, dance, and weight training.

### **229-1 Body Conditioning Skills I (1) CSU**

*Lecture: 0.5 hour; Activity: 1.5 hours*

This course will direct students to a variety of cardiovascular, strength, endurance and flexibility exercises using a mix of equipment and environment to improve

students fitness and health. Students will learn how to create a balanced fitness program based on current research to reach their goals. Fitness assessments will be conducted to provide students with feedback and recommendations for progressive improvement.

### **234 Walking for Fitness (1) CSU RPT 3**

*Lecture .5; Activity 1.5*

Students focus on achieving cardiovascular fitness and a healthy lifestyle through walking programs and gate training. Course topics include shoe selection, posture, gait, walking styles, flexibility, clothing, creating a walking program, nutrition, BMI, cardiovascular disease prevention and assessing fitness level.

### **245 Body Dynamics (1) UC:CSU, RPT 3**

*Activity: 2 hours*

This course is designed to provide challenging fitness activities by combining resistant exercises with endurance exercises. Emphasis is placed on aerobic activity and resistant exercises based on individual age and physical condition. Nutrition, diet and body mechanics will also be discussed.

### **250 Weight Training Skills (1) UC:CSU RPT 3**

*Activity: 2 hours*

This course emphasizes the knowledge, understanding and values of weight training and its role in developing muscular strength and endurance. Students will learn fundamental weight and resistance training skills and techniques and will create their own weight training program based upon multiple dimensions of health and fitness. Proper form and safety will be stressed.

### **251 Yoga Skills (1) UC:CSU RPT 3**

*CSU-GE Area E*

*Activity: 2 hours*

This course is an introduction to basic yoga practices and principles. Instruction includes yoga postures and poses and guided meditation to develop balance, flexibility, and strength. Students will explore controlled breathing techniques to increase focus and concentration. Yoga promotes mental, physical, and spiritual fitness.

### **251-2 Yoga Skills II (1) CSU**

*Activity: 2 hours*

This course is designed to improve both strength and flexibility through mind and body integration. The course focuses on the physical and breathing exercises of Yoga. It will assist with the development of flexibility and strength in the skeletal, muscular, and nervous systems, improve circulation, reduce stress, and increase energy levels. Various styles of Hatha Yoga will be studied and practiced. This course will give the student both the knowledge and the practice to move toward improved health and reduce stress levels.

### **287 Basketball Skills (1) UC:CSU RPT 3**

*Activity: 2 hours*

This course offers instruction and practice in the fundamentals and basic techniques of basketball. Instruction will include proper techniques and body placement, balance and footwork when dribbling, passing, catching, and shooting the basketball.

### **288 Flag/Touch Football Skills (1) UC:CSU RPT 3**

*Activity: 2 hours*

Basic skills of punting, passing, catching and carrying the football are taught. Instruction includes foot placement, positioning for blocking, tackling, ball handling (offense & defense), change of direction associated with accelerating and decelerating, hand and finger position for passing and catching the football. A balance of skill and game development is developed through flag football games. Open to all ability levels.

### **289-1 Soccer Skills I (1) CSU**

*Lecture: 0.5 hour; Activity: 2.5 hours*

This course is designed to teach students the basic soccer skills of passing, dribbling, shooting, and goalkeeping. The course also introduces basic theories of individual and team offense and defense, as well as the Laws of the Game, proper etiquette, terminology, and the components of fitness.

### **300 Swimming - Non-Swimmer (1) UC:CSU RPT 3**

*Activity: 2 hours*

This course is designed to teach the beginning skills of swimming: front crawl, elementary backstroke, sidestroke, racing backstroke, and breaststroke. The course will introduce the principles and strategies of swimming endurance. Students will be able to perform the basic strokes, know the rules that govern the different strokes, understand the nutrition and injury prevention strategies for swimming.

### **300-1 Swimming - Non-Swimmer 1 (1) CSU**

*Lecture: 0.5 hour; Activity: 1.5 hours*

The purpose of this course is to teach beginning swimmers (those with LIMITED or NO swimming skills) how to correctly perform basic swimming skills. The course focuses on teaching students general swimming skills (arm stroke, leg kick, and breathing) and specific swimming strokes, including the four competitive strokes (front crawl, back crawl, breast stroke, butterfly stroke) the elementary backstroke, the side stroke and treading skills. Ability to perform skills to ensure water survival and understand and use basic swimming etiquette.

### **301-1 Swimming Skills I (1) CSU**

*Lecture: 0.5 hour; Activity: 1.5 hours*

The purpose of this course is to teach beginning swimmers how to correctly perform basic swimming skills. The course focuses on teaching students general swimming skills (arm stroke, leg kick, and breathing) and specific swimming strokes, including the five basic strokes (front crawl, backstroke, breast stroke, sidestroke, and elementary back stroke). Ability to perform skills to ensure water survival and understand/use basic swimming etiquette.

### **303 Aqua Aerobics (1) UC:CSU RPT 3**

*IGETC Area*

*CSUGE Area*

*Activity: 3 hours*

This is an aerobic physical program employing water resistive exercises without the need of swimming skills. This class is designed to help promote cardiovascular and muscular fitness.

### **327 Lifelong Fitness Lab (1) UC:CSU**

*Lecture: 0.5 hour; Activity: 2.5 hours*

Through this physical fitness course, students design procedures for evaluating individual fitness levels. A progression of lifelong fitness exercises for all major muscle groups to improve cardiovascular fitness, muscular strength/endurance, flexibility and body composition are



examined.

### 329-2 Body Conditioning II (1) CSU

*Lecture: 0.5 hour; Activity: 2.5 hours*

This class is designed to incorporate intermediate forms, concepts and techniques associated with body conditioning. Including Pilates, Core Strengthening, Cardiovascular Exercise and Muscular Strength and Endurance exercises.

### 329-3 Body Conditioning III (1) CSU

*Lecture: 1 hour*

Body Conditioning intermediate concepts and mastery of exercise techniques associated with the application of exercise concepts to design an individualize exercise program implementing concepts discussed in class. Concepts discussed include: Muscle anatomy, Muscle Fiber Recruitment, Cardiovascular Adaptations to Exercise, Muscle adaptation to Specific Loads, and Energy systems utilized in cardiovascular exercise training. Methods incorporated in class activities include: Pilates Core Strengthening, Cardiovascular Exercise, Muscular Strength and Endurance, Flexibility; and Body Composition.

### 334 Walking for Fitness (1) UC:CSU RPT 3

*CSUGE Area E*

*Activity: 2 hours*

This course focuses on achieving cardiovascular fitness and a healthy lifestyle through walking. Course topics include shoe selection, posture, gait, walking styles, flexibility, clothing, creating a walking program, and assessing fitness level.

### 336-1 Zumba Fitness I (1) CSU

*Lecture: 0.5 hour; Activity: 2.5 hours*

Zumba integrates some of the basic principles of aerobic, interval, and effective fitness resistance training to maximize caloric output, cardiovascular benefits, and total body toning. Zumba provides a non-intimidating opportunity for non-dancers to participate in a group aerobic class. This course enables the student to participate in basic Zumba group exercise that combines a fusion of high energy Latin and International Diaspora music with unique moves and combinations.

### 345 Body Dynamics Activity (1) UC:CSU RPT 3

*CSUGE Area E*

*Activity: 3 hours*

Emphasis is on physical fitness through a regular exercise program including low/high impact aerobics performed to music, and nutrition, diet and body mechanics information.

### 389-1 Soccer I (1) CSU

*Lecture: 0.5 hour; Activity: 2.5 hours*

This course is designed to teach students the basic soccer skills of passing, dribbling, shooting, and goalkeeping. The course also introduces basic theories of individual and team offense and defense, as well as the Laws of the Game, proper etiquette, terminology, and the components of fitness. Students learn proper soccer techniques with practice skills and feedback.

### 391 Volleyball (1) CSU

*Lecture: 0.5 hour; Activity: 2.5 hours*

This course is designed to teach the basic volleyball skills of passing, setting, spiking, serving and blocking. The course will introduce individual and team offense and defense systems, as well as the rules, etiquette, terminology and strategies for volleyball.

## KINESIOLOGY ATHLETICS

### 504 Intercollegiate Sports - Basketball (3) UC:CSU RPT2

*Activity: 10 hours*

This course is designed to develop individual and team skills in basketball so that the student can compete on the intercollegiate level. Basketball theory, strategies, offense, defense, ball-handling skills (including passing, dribbling, shooting, rebounding), individual and team offense/defense and basketball intercollegiate competition experiences are emphasized.

### 508 Intercollegiate Sports – Football (3)

**UC:CSU RPT1**

*Activity: 10 hours*

As an intercollegiate athletic competitive football team course, advanced skills for blocking, tackling, ball carrying (offense & defense), running, change in direction, accelerating and decelerating and placement of hands and fingers on football are emphasized.

### 552 Athletic Pre-Season Conditioning (1)

**UC:CSU RPT 3**

*CSUGE Area E*

*Activity: 3 hours*

This course is designed for the student athlete. The following areas are emphasized: the analysis and training of athletic skills, the analysis of offensive and defensive systems, physical conditioning, strength training and aerobic conditioning.

## KINESIOLOGY MAJOR

### 100 Introduction to Kinesiology (3) CSU

*Lecture: 3 hours*

This course is an introduction to the discipline of Kinesiology/Physical Education; and examines human movement from the perspectives of experience, research, and professional practice. Topics include career opportunities, history, philosophy, psychology, sociology, current trends, physiology, and curriculum development in the field of kinesiology.

### 101 First Aid and CPR (3) CSU

*Lecture: 3 hours*

This course involves the theory and detailed demonstration of the first aid care of the injured. The student will learn to assess a victim's condition and incorporate proper treatment. Standard first aid, CPR, and AED certification(s) will be granted upon successful completion of requirements. This course also covers the recommendations by the American Heart Association, National Safety Council, ECSI (Emergency Care Safety Institute) and the American National Red Cross for community members to respond to non-breathing and sudden cardiac emergencies. Includes techniques for all ages along with emergency action plans, safety, and prevention of disease transmission.

### 117 Personal Trainer Instructor (3) CSU

*Lecture: 2 hours; Activity: 2 hours*

This course is designed to give students the knowledge and understanding necessary to prepare for the NASM Personal Trainer Certification Exam and become effective personal trainers. This is a comprehensive course for designing individualized programs based on each client's unique health, fitness, and goals. The information covered by this course will help students learn how to facilitate rapport, adherence, self-efficacy and behavior change in clients, as

well as design programs that help clients to improve posture, movement, flexibility, balance, core function, cardiorespiratory fitness, and muscular endurance and strength.

### 134 Advanced Lifesaving (2) CSU

*Lecture: 1 hour; Activity: 2 hours*

Theory and analysis of lifesaving and water safety skills are studied. This course is a requirement for water safety instructor's courses. Upon successful completion, an American Red Cross certificate is issued.

## LAW

### 3 Civil Rights and the Law (3) UC:CSU

*CSUGE Area D8*

*Prerequisites: Law 3 and English 101*

*Lecture: 3 hours*

Comparative and analytical study of the law and related problems concerning Civil Rights. Due process of law, freedom of expression, freedom of religion, racial equality, and democratic processes are studied with emphasis on recent court decisions and international trends.

### 10 Introduction to Legal Assistant I (3) CSU

*Lecture: 3 hours*

This is an introductory course in understanding the role of the legal assistant in the practice of law. Emphasis is also placed on the roles of the lawyer, law office personnel, and all other parties involved in the law practice. Legal terminology and research problems are covered.

### 13 Wills, Trusts, and Probate Administration (3) CSU

*Lecture: 3 hours*

This course is a study of the fundamental principles of the law of wills and trusts, including simple will and trust forms and formation; it is also an examination of the organization and jurisdiction of the California Probate Court and of the administration of estates in California Probate Courts including gift, inheritance and estates taxes.

### 17 Legal Writing (3) CSU

*Lecture: 3 hours*

This course instructs students in the aspects of advanced legal drafting and writing, including special research and projects.

### 51 Legal Research for Paralegals (3) CSU

*Lecture 3 hours*

The student will gain a working knowledge of legal research methods, both in traditional print and electronic formats. The student will be exposed to materials not necessarily covered in other courses.

## LIBRARY SCIENCE

### 101 Library Research Methods (1) UC:CSU

*Lecture: .5 hours; Lab: 1.5 hours*

Students learn to conduct research using the library's print and electronic resources, to distinguish between academic and popular sources, to develop research and organizational strategies for research assignments, to apply citation rules to their assignments, and to understand the basic requirements of copyright law and academic integrity. MLA and APA citation styles will also be discussed.

### 102 Internet Research Methods (1) UC:CSU

*Lecture: 1 hour*

This course will focus on finding and evaluating information and resources on the Internet. Principles of information access, search tools, search strategies, evaluation criteria, intellectual property and MLA and APA citation styles will also be discussed.

## MANAGEMENT

### 2 Organization and Management Theory (3) CSU

*Lecture: 3 hours*

This an introductory course in which the basic fundamentals of management are analyzed in detail. Topics include: Planning-strategic, intermediate, and operational; organizing-committees, span of control, authority, delegation and organizational structures; controlling-traditional and specialized techniques; tools of decision making, information systems, operations, motivation theories, leadership, and human resource development.

### 13 Small Business Entrepreneurship I (3) CSU

*Lecture: 3 hours*

This course is designed to teach the student how to organize and operate a small business.

### 31 Human Relations for Employees (3) CSU

*Lecture: 3 hours*

This course presents the practical application of basic psychology in planning, conducting and evaluating conferences and interviews. Special emphasis on dynamics of counseling, interviewing and conference leading. Attention is given to individual and group attitudes in the occupational situation as they affect motivation, status and morale.

### 33 Personnel Management (3) CSU

*Lecture: 3 hours*

This course provides an overview of personnel administration and supervision, job analysis, recruitment, selection and placement of the candidates, employment training and development, performance appraisal, position compensation and benefits, motivation, employee rights, and union-management relations.

## MATHEMATICS

### 100 Mathematics Workshop (1)

*Corequisite: Math 105, or 110, or 112, or 113, or 114, or Math 115*

*Lecture: 3 hours*

Students can supplement and enhance learning in mathematics through tutorial and self-help assistance, calculators, computers, programmed texts and other learning aids.

### 105 Arithmetic (3) NDA

*Lecture: 3 hours; Lab: 1 hour*

This course is a review of fundamental arithmetic essential to succeed in many areas of study at the college level and in industry. Topics include basic operations with whole numbers, fractions, decimals, percentages, ratios and proportions and word problems involving basic operations.

### 110 INTRODUCTION TO ALGEBRAIC CONCEPTS (5) NDA

*Lecture: 5 hours; Lab: 1 hour*





This course covers the fundamentals of arithmetic through beginning algebra skills that are essential for Elementary Algebra. Operations on whole numbers, fractions, decimals, and integers; grouping symbols and order of operations; ratios, proportions, percent's, and applications; basic geometric formulas, expressions with variables, operations on polynomials, linear equations, and basic graphing are included.

*Note: Math 110 is an accelerated pathway option preparing students for Math 115 (Elementary Algebra). The material covered is equivalent to that covered separately in Math 105 (Arithmetic) and Math 112 (Pre-Algebra). Course credit may not be applied toward satisfaction of associate degree requirements.*

### 112 Pre-Algebra (3) NDA

*Lecture: 3 hours; Lab: 1 hour*

The course reviews the fundamentals of arithmetic and covers the beginning algebra skills that are essential for Elementary Algebra. Topics covered include Integers, Simple Algebraic Expressions and Equations, Basic Geometry, Fractions, Decimals, Order of Operations, Ratio, Proportion, and Percent. Basic word problems and negative numbers are used throughout the course.

### 113 Elementary Algebra A (3) NDA

*Prerequisite: Mathematics 112*

*Lecture: 3 hours; Lab: 1 hour*

This course is the first half in a two-part sequence equivalent to Math 115. Topics include arithmetic operations with signed numbers, properties of real numbers, algebraic expressions, linear equations and inequalities, graphing linear equations and inequalities in two variables, solving systems of linear equations and inequalities, exponents and polynomials.

*Note: Math 113 and 114 together are equivalent to Math 115.*

### 114 Elementary Algebra B (3) NDA

*Prerequisite: Mathematics 113*

*Lecture: 3 hours; Lab: 1 hour*

This is the second half in a 2-part sequence. Topics include exponents and polynomials, factoring, rational expressions, roots and radicals and methods of solving quadratic equations. *Note: Math 113 and 114 together are equivalent to Math 115.*

### 115 Elementary Algebra (5) NDA

*Prerequisite: Mathematics 112*

*Lecture: 5 hours; Lab : 1 hour*

This course is an introduction to the concepts of algebra. Topics include arithmetic operations with signed numbers, properties of real numbers, algebraic expressions, solving linear equations and inequalities, graphing linear equations and inequalities in two variables, solving systems of linear equations and inequalities, exponents, polynomials, factoring, rational expressions, roots, radicals, methods of solving quadratic equations, and setting up and solving a variety of word problems.

### 122 Intermediate Algebra for Statistics (5)

*Prerequisite: Mathematics 115*

*Lecture: 5 hours*

This course provides a study of fundamental laws, exponents, radicals, equations (linear, quadratic, and some higher degree), systems of linear equations (2x2 systems only), Inequalities (linear and quadratic), graphic representation, logarithms, equations of circles, Sequences and series, factoring polynomials, and the binomial theorem.

*Note: Mathematics 122 serves as prerequisite course for all transfer-level mathematics course sequences, except the sequences (Math 235, 236, 240, 245, 260, 265, 266, 267, 270, and 275). Math 122 is designed as the prerequisite course for students (Liberal Arts and Social Science majors) who are required to complete Math 227 (Statistics) for transfer. For an AA degree, LASC requires the successful (with a grade of C or better) completion of Math 125/Math 122 or a passing score on the mathematics competency exam.*

### 125 Intermediate Algebra (5)

*Prerequisite: Mathematics 114 or 115*

*Lecture: 5 hours*

This course provides a study of fundamental laws, exponents, radicals, equations (Linear, quadratic, and some of higher degree), systems of equations (linear and quadratic), graphic representation, logarithms determinants, and matrices.

### 215 Principles of Mathematics I (3) UC:CSU

*CSUGE Area B4*

*Prerequisite: Mathematics 125*

*Lecture: 3 hours*

A course designed primarily for students who plan to teach in elementary school. The course covers the language of sets; elementary logic; systems of numeration; nature of numbers; fundamental operations, rational numbers and fractions: decimals, percents, and real numbers; and various algorithms used in calculations.

### 216 Principles of Mathematics II (3) UC:CSU

*Prerequisite: Mathematics 215*

*Lecture: 3 hours*

This course is the second of two for prospective elementary teachers. Topics include decimal and real numbers, geometry and the metric system. Topics in probability, statistics, and elementary analytic geometry will also be presented.

### 227 Statistics (4) UC:CSU

*IGETC Area 2A*

*CSUGE Area B4*

*Prerequisite: Mathematics 122 or 125*

*Lecture: 4 hours*

This course is an introduction to statistics and probability, measures of central tendency and dispersion, descriptive and inferential statistics including sampling, estimation, hypothesis testing, analysis of variance, normal curve, Chi-square and student's t distributions. Linear correlation and regression analysis and applications in diverse disciplines are also presented as topics.

### 230 Mathematics for Liberal Arts Students (3) UC:CSU

*IGETC Area 2A*

*CSUGE Area B4*

*Prerequisite: Mathematics 122 or 125*

*Lecture: 3 hours*

This course is intended for Liberal Arts majors. Topics include sets and counting, probability, linear systems, linear programming, logic, statistics and mathematics of finance with applications for liberal arts majors.

### 235 Finite Mathematics (5) UC:CSU

*IGETC Area 2A*

*CSUGE Area B4*

*Prerequisite: Mathematics 125*

*Lecture: 5 hours*

This course reviews algebra; it introduces students to mathematics of finance; linear programming and the simplex method; logic of inclusion and exclusion; topics in probability such as counting principles, probability, random variables, Markov chain; and elementary statistics.

### **236 Calculus for Business and Social Science (5) UC:CSU**

*IGETC Area 2A*

*CSUGE Area B4*

*Prerequisite: Mathematics 125*

*Lecture: 5 hours*

This course covers techniques of limits, differentiation; maximum-minimum problems; curve sketching; implicit differentiation; techniques of integration and differential equations. Special emphasis is placed on business and economics applications related to system optimization, cost and revenue analysis, marginal analysis and consumer and producer surplus.

### **240 Trigonometry (3) CSU**

*CSUGE Area B4*

*Prerequisite: Mathematics 125*

*Lecture: 3 hours*

This course covers the solution of triangles, problems and applications, radian measure, trigonometric functions and their inverses, identities, trigonometric equations, and graphs of trigonometric functions.

### **245 College Algebra (3) UC:CSU**

*IGETC Area 2A*

*CSUGE Area B4*

*Prerequisite: Mathematics 125*

*Lecture: 3 hours*

This is a function oriented course. Topics covered in this course include linear, rational and quadratic equations and inequalities; polynomial, rational, inverse, exponential, and logarithmic functions and their graphs. Other topics include matrices, conic sections, sequences and series, the Binomial Theorem, permutations, combinations, and probability.

### **260 Pre-Calculus (5) UC:CSU**

*IGETC Area 2A*

*CSUGE Area B4*

*Prerequisite: Mathematics 240*

*Lecture: 5 hours*

This course combines college algebra, trigonometry, and introduction to analytic geometry. Topics in algebra include polynomial, rational, exponential and logarithmic functions; mathematical induction, systems of equations, matrices, partial fractions, and sequences. Topics in trigonometry include basic trigonometric functions; inverse trigonometry; and trigonometric equations and identities.

### **265 Calculus with Analytic Geometry I (5) UC:CSU**

*IGETC Area 2A*

*CSUGE Area B4*

*Prerequisites: Mathematics 240 and Math 245 or Math 260*

*Lecture: 5 hours*

This course includes a study of functions and limits, continuity derivatives and their applications, differentials and integrals and their applications.

### **266 Calculus with Analytic Geometry II (5) UC:CSU**

*IGETC Area 2A*

*CSUGE Area B4*

*Prerequisite: Mathematics 265*

*Lecture: 5 hours*

This is a unified course in analytic geometry and calculus including applications of the definite integral, inverse functions, logarithmic functions, exponential functions, inverse trigonometric functions and hyperbolic functions, techniques of integration, indeterminate forms and improper integrals.

Polar coordinates, conic sections, infinite series and sequences will also be presented.

### **267 Calculus with Analytic Geometry III (5) UC:CSU**

*IGETC Area 2A*

*CSUGE Area B4*

*Prerequisite: Mathematics 266*

*Lecture: 5 hours*

Topics included in this course are solid analytic geometry; vector algebra; partial derivatives; line, surface, and volume integrals; multiple integrals; vector field theory; Green's Theorem; Stokes Theorem and Gauss Theorem.

### **270 Linear Algebra (3) UC:CSU**

*IGETC Area 2A*

*CSUGE Area B4*

*Prerequisite: Mathematics 266*

*Lecture: 3 hours*

This course covers linear equations, matrices, vector spaces, inner product spaces, linear transformations, determinants, eigenvalues and eigenvectors and solutions of systems of linear equations.

### **275 Ordinary Differential Equations (3) UC:CSU**

*IGETC Area 2A*

*CSUGE Area B4*

*Prerequisite: Math 267*

*Lecture: 3 hours*

This course includes a study of differential equations in general, first-order and simple higher-order ordinary differential equations; applications of first-order and higher-order differential equations; linear differential equations; solution of linear differential equations by Laplace transformations; solutions of differential equations by use of power series.

## **MICROBIOLOGY**

### **1 Introductory Microbiology (5) UC:CSU**

*IGETC Area 5B, 5C*

*CSUGE Area B2, B3*

*Prerequisite: Chemistry 51 and (Biology 3 or Physiology I or Biology 5 or Biology 20)*

*Lecture: 3 hours; Lab: 6 hours*

This course utilizes the theoretical approach to the study of microorganisms and offers the student a comprehensive knowledge of the fundamentals of microbiology. It includes an introduction to the history of microbiology; classifications and identification of microorganisms; physiology and biology (nutrition, metabolism, growth, variability, etc) of microorganisms; microbiology of air, water, soil, food, sewage; industrial and medical microbiology. Laboratory experiments using appropriate techniques and methods of handling and investigating microorganisms are introduced in order to reinforce the lectures.



## MANUFACTURING & INDUSTRIAL TECHNOLOGY

### 220 Introduction to Robotics (3) CSU

*Lecture: 2 hours; Lab: 2 hours*

This introductory course in robotics emphasizes hands-on experience to build a basic functional robot. Students learn about electric motors, servos, sensors, switches, actuators and their application in a robot. Students learn BASIC Stamp computer programming and its integration into a working robotic unit. The course also includes mechanical assembly, connecting electronic components, wiring and soldering, and testing.

## MUSIC

### 101 Fundamentals of Music (3) UC:CSU

*Lecture: 3 hours*

An introduction to reading and writing music including the study of pitch and notation, rhythm, scales, intervals, chords, and the keyboard. Intended for students who have no music reading ability. Provides essential background for more advanced courses in music theory.

### 111 Music Appreciation I (3) UC:CSU

*IGETC Area 3A  
CSUGE Area C1  
Lecture: 3 hours*

This course is an introduction to American, World and Western Classical music. The course introduces students to oral and written traditions and focuses on social milieu and the basic elements of music.

### 116 Survey and History of Rock, Pop and Soul Music (3) UC:CSU

*IGETC Area 3A  
CSUGE Area C1*

*Lecture: 3 hours*

Introduction to rock, pop, and soul music styles covering their origins, stylistic development and cultural impact. This course is designed to increase student awareness of the relationship between popular music and society.

### 141 Jazz Appreciation (3) UC:CSU

*CSUGE Area C1  
Lecture: 3 hours*

An introduction to American jazz music including its origins, stylistic development and cultural impact. This course is designed to increase student awareness of the relationship between jazz music and American society.

### 161 Introduction to Electronic Music (3) CSU

*Lecture 2 hours; Lab 2 hours*

An introduction to digital audio production and performance using Ableton Live software. The course focuses on desktop audio production basics, manipulating digital audio, drum programming, computer-assisted live performance, mixing, mastering, and distribution.

### 181 Applied Music I (0.5) CSU

*Prerequisite: Placement Exam  
Lecture: 1 hour*

This course consists of individualized study of the appropriate techniques and repertoire for the specific instrument or voice being studied. The emphasis is on the

progressive development of skills needed for solo performance. Achievement is evaluated through a juried performance.

### 182 Applied Music II (0.5) CSU

*Prerequisite: Music 181  
Lecture: 1 hour*

Second semester continuation of individualized study of the appropriate techniques and repertoire for the specific instrument or voice being studied. The emphasis is on the progressive development of skills needed for solo performance. Achievement is evaluated through a juried performance.

### 183 Applied Music III (0.5) CSU

*Prerequisite: Music 182  
Lecture: 1 hour*

Third semester continuation of individualized study of the appropriate techniques and repertoire for the specific instrument or voice being studied. The emphasis is on the progressive development of skills needed for solo performance. Achievement is evaluated through a juried performance.

### 184 Applied Music IV (0.5) CSU

*Prerequisite: Music 183  
Lecture: 1 hour*

Fourth semester continuation of individualized study of the appropriate techniques and repertoire for the specific instrument or voice being studied. The emphasis is on the progressive development of skills needed for solo performance. Achievement is evaluated through a juried performance.

### 201 Harmony I (3) UC:CSU

*Prerequisite: Music 101  
Recommended: Music 211  
Lecture: 3 hours*

A study of theoretical concepts used in musical composition and analysis, including pitch, rhythm, diatonic triads and seventh chords, and elementary part-writing. Recommended to be taken concurrently with Music 211 (Musicianship I).

### 202 Harmony II (3) UC:CSU

*Prerequisite: Music 201  
Lecture: 3 hours*

This course is correlated with Musicianship II and includes a study of secondary triads, secondary seventh chords, ninth, eleventh and thirteenth chords, augmented sixth chords, and non-chordal tones. Harmonic analysis is an integral part of the course.

### 203 Harmony III (3) UC:CSU

*Prerequisite: Music 202  
Lecture: 3 hours*

This course offers a study of chromatic harmony and modulation to distantly related keys through analysis and composition. The course also introduces the student to the techniques of Twentieth-Century music.

### 211 Musicianship I (2) UC:CSU

*Prerequisite: Music 101  
Lecture: 1 hour; Lab: 2 hours*

This is a basic course for students intending to continue as music majors or music minors. The course includes melodic, rhythmic and two part harmonic ear training, the keyboard study of material covered in Harmony I (Music 201), music terminology and the analysis of melodies and

simple forms.

### **212 Musicianship II (2) UC:CSU**

*Prerequisite: Music 211*

*Lecture: 1 hour; Lab: 2 hours*

This course includes advanced sight reading involving simple and compound meters, melodic dictation in two parts and harmonic dictation in three parts. Also included is a study of longer structural forms such as Variation and Sonata-allegro form.

### **213 Musicianship III (2) UC:CSU**

*Prerequisite: Music 212*

*Lecture: 1 hour; Lab: 2 hours*

This course, which is a continuation of Music 212, includes advanced sight reading, melodic dictation in three parts and harmonic dictation in four parts. Also included is a study of structural forms such as Passacaglia, Chaconne, Rondo and Sonata Rondo.

### **216-1 Music Theory I (3) CSU**

*Corequisite: Music 217-1*

*Recommended: Music 101*

*Lecture: 3 hours*

This course, through guided composition and analysis, incorporates the following concepts: rhythm and meter; basic properties of sound; intervals; diatonic scales and triads; diatonic chords, basic cadential formulas and phrase structure; dominant seventh; figured bass symbols; and non-harmonic tones. Development of skills in handwritten notation is expected.

### **216-2 Music Theory II (3) CSU**

*Prerequisite: Music 216-1*

*Corequisite: Music 217-2*

*Lecture: 3 hours*

This course incorporates the concepts from Music Theory I. In addition, through guided composition and analysis, the course will include: an introduction to two-part counterpoint; voice leading involving four-part chorale writing; diatonic harmony; and an introduction to secondary/applied chords and modulation.

### **216-3 Music Theory III (3) CSU**

*Prerequisite: Music 212 and 216-2;*

*Corequisite: Music 213*

*Lecture: 3 hours*

This course incorporates the concepts from Music Theory II. In addition, through writing and analysis, the course will include: introduction to chromatic harmony; secondary/applied chords; modulation; borrowed chords; introduction to Neapolitan and augmented-sixth chords.

### **216-4 Music Theory IV (3) CSU**

*Prerequisite: Music 213 and 216-3*

*Corequisite: Music 214*

*Lecture: 3 hours*

This course incorporates the concepts from Music Theory III. In addition, through writing and analysis, the course will include: post-Romantic techniques such as borrowed chords and modal mixture, chromatic mediants, Neapolitan and augmented-sixth chords, 9th, 11th and 13th chords, altered chords and dominants; and 20th century techniques such as: Impressionism, tone rows, set theory, pandiatonicism and polytonalism, meter and rhythm.

### **217-1 Musicianship I (1) CSU**

*Prerequisite: Music 216-1*

*Recommendation: Music 101*

*Lab: 3 hours*

This course applies and develops the rhythmic, melodic, and harmonic materials of Music Theory I through ear training, sight singing, analysis, and dictation.

### **217-2 Musicianship II (1) CSU**

*Prerequisite: Music 216-1 and 217-1*

*Corequisite: Music 216-2*

*Lab: 3 hours*

This course applies and develops the rhythmic, melodic, and harmonic materials of Music Theory II through ear training, sight singing, analysis, and dictation.

### **217-3 Musicianship III (1) CSU**

*Prerequisites: Music 216-2 and 217-2*

*Corequisite: Music 216-3*

*Lab: 3 hours*

This course applies and develops the rhythmic, melodic, and harmonic materials of Music Theory II through ear training, sight singing, analysis, and dictation.

### **217-4 Musicianship IV (1) CSU**

*Prerequisites: Music 216-3 and 217-3*

*Corequisite: Music 216-4*

*Lab: 3 hours*

This course applies and develops the rhythmic, melodic, and harmonic materials of Music Theory II through ear training, sight singing, analysis, and dictation.

### **261 Electronic Music Workshop (3) CSU**

*Prerequisite: Music 161*

*Recommended: Music 101*

*Lecture 2 hours; Lab 2 hours*

Continued study of digital audio production and performance using Ableton Live software. The course focuses on Midi, sampling, sound design basics, advanced production techniques and advanced controller techniques.

### **321 Elementary Piano I (2) UC:CSU**

*Lecture: 1 hour; Lab: 2 hours*

An introduction to the fundamentals of playing piano including notation, basic music theory, terminology, technique, and repertoire.

### **322 Elementary Piano II (2) UC:CSU**

*Prerequisite: Music 321*

*Lecture: 1 hour; Lab: 2 hours*

The fundamentals of playing piano building on Music 321. Includes the study of notation, basic music theory, terminology, technique, and repertoire.

### **323 Elementary Piano III (2) UC:CSU**

*Prerequisite: Music 322*

*Lecture: 1 hour; Lab: 2 hours*

The fundamentals of playing piano building on Music 322. Includes the study of notation, basic music theory, terminology, technique, and repertoire.

### **324 Elementary Piano IV (2) UC:CSU**

*Prerequisite: Music 323*

*Lecture: 1 hour; Lab: 2 hours*

The fundamentals of playing piano building on Music 323. Includes the study of technique, harmonization, transposition, accompaniment, and advanced repertoire.

### **411 Elementary Voice I (2) UC:CSU**

*Lecture: 1 hour; Lab: 2 hours*

This course is an introduction to the repertoire, diction, stage presence, and vocal technique of solo singing.

**412 Elementary Voice II (2) UC:CSU***Prerequisite: Music 411**Lecture: 1 hour; Lab: 2 hours*

This course expands on the repertoire, diction, stage presence, and vocal technique of solo singing introduced in Elementary Voice I.

**413 Elementary Voice III (2) UC:CSU***Prerequisite: Music 412**Lecture: 1 hour; Lab: 2 hours*

An intermediate study of solo singing including musical notation, diction, repertoire and music industry.

**414 Elementary Voice IV (2) UC:CSU***Prerequisite: Music 413**Lecture 1 hour; Lab: 2 hours*

A continuation of Elementary Voice III with an emphasis on repertoire, musical notation, diction and music industry.

**501 College Choir (1) UC:CSU***Lab: 3 hours*

The student studies and performs selected choral literature for mixed voices. Emphasis is on increased skill in music reading, development of basic voice and ensemble techniques, and improving musicianship.

**650 Beginning Guitar (2) UC:CSU RPT 1 (Pass/No Pass Optional)***Lecture: 1 hour; Lab: 2 hours*

This course focuses on basic fundamentals which prepare the student for most styles of guitar playing. Emphasis on chordal accompaniment, right-hand techniques, melodic playing, and basic music reading. Student must provide own guitar for use in class.

**NURSING****185 Directed Study – Nursing (1) CSU (Pass/No Pass)***Lecture: 2 hours*

This course allows students the opportunity to pursue directed study in Nursing on a contract basis under the direction of a supervising instructor. Study is coordinated under the direction of a supervising instructor with current course content and skill development.

**285 Directed Study – Nursing (2) CSU (Pass/No Pass)***Lecture: 2 hours*

This is a Credit/No Credit course for Nursing students. It will provide students the opportunity to improve their comprehension and further develop study and investigative skills necessary for success in nursing. This course will be offered under the supervision of a Nursing faculty member.

**385 Directed Study – Nursing (3) CSU (Pass/No Pass)***Lecture: 3 hours*

This course allows students the opportunity to pursue directed study in Nursing on a contract basis under the direction of a supervising instructor.

**399A Nursing Assistant Training Program (5)***Lecture: 3 hours; Lab: 6 hours*

This combined lecture/lab course teaches the student the

theory and clinical skills needed to work with residents/patients in the long-term care facility. Emphasis is given to safety principles, infection control, methods for providing physical care, emotional and social support. After the successful completion of this course, the student will be eligible to apply for certification and to take the State of California Certified Nurse Assistant examination.

**399B Home Health Aide Training Program (2)***Prerequisite: Nursing 399A**Lecture: 1 hour; Lab: 2 hours*

This combined lecture/lab course teaches the student the theory and clinical skills needed to work with Clients/Patients in the home care setting. Emphasis is given to safety principles and the methods of providing physical care, emotional and social support. This course is for the student who has completed a 150 Hour Nurse Aide Training Program and who already possesses a nurse assistant certificate. Upon successful completion of this course, the student is eligible to apply for certification as a Home Health Aide in the state of California.

**501A Fundamentals of Nursing A (4.5) CSU***Prerequisites: Admission to the Nursing Program , Sociology 1 and Communication Studies 101**Corequisite: Nursing 527**Lecture: 4.5 hours; Lab: 17 hours – 8 week course*

This course utilizes Orem's Self-Care Deficit Theory of Nursing (S-CDTN) and the Nursing Process to focus on health deviation, self-care requisites related to problem areas of Medical Asepsis; Physical Assessment; Promotion of Comfort, Sleep, Hygiene and Safety; Oxygenation; Nutrition; and Stress, Loss, Death and Dying. Developmental self-care requisites will be addressed with a focus on the care of adult clients, geriatric clients and their families. Principles of therapeutic interventions, basic conditioning factors, communications and care of the client across the life span will be integrated throughout the course. The role of the provider of care, manager of care, and members within the profession are stressed. Guided clinical experiences are provided concurrently with the theory.

**501B Fundamentals of Nursing B (4.5) CSU***Prerequisites: Admission to the Nursing Program , Nursing 501A and 527**Corequisite: Nursing 526**Lecture: 4.5 hours; Lab: 17 hours. – 8 week course*

This course utilizes Orem's Self-Care Deficit Theory of Nursing (S-CDTN) and the Nursing Process to focus on health deviation, self-care requisites related to problem areas of pharmacology, care of the surgical patient, fluid and electrolytes imbalances, Diabetes Mellitus and musculoskeletal trauma. Developmental self-care requisites will be addressed with a focus on the care of adult clients, geriatric clients and their families. Principles of therapeutic interventions, basic conditioning factors, communications and care of the client across the life span will be integrated throughout the course. The role of the provider of care, manager of care, and members within the profession are stressed. Guided clinical experiences are provided concurrently with the theory.

**502A Medical-Surgical Nursing A (4.5) CSU***Prerequisites: Nursing 501B and 526**Lecture: 4.5 hours; Lab: 17 hours – 8 week course*

This course utilizes Orem's Self-Care Deficit Theory of Nursing (S-CDTN) and the Nursing Process to focus on health deviation, self-care requisites related to problem areas of hematology, oncology, musculoskeletal and

inflammatory disease, renal and urological problems, sensory problems, intravenous therapy and community nursing. Developmental self-care requisites will be addressed with a focus on the care of adult clients, geriatric clients and their families. Principles of therapeutic interventions, basic conditioning factors, communications and care of the client across the life span will be integrated throughout the course. The role of the provider of care, manager of care and members within the profession are stressed. Guided clinical experiences are provided concurrently with the theory.

### **502B Medical-Surgical Nursing B (4.5) CSU**

*Prerequisite: Nursing 506A*

*Lecture: 4.5 hours; Lab: 17 hours – 8 week course*

This course utilizes Orem's Self-Care Deficit Theory of Nursing (S-CDTN) and the Nursing Process to focus on health deviation, self-care requisites related to problem areas of Intravenous Therapy, Elimination problems, Gastrointestinal, Liver, Biliary and Pancreatic problems, aging Endocrine dysfunction and Peripheral Vascular disorders. Developmental self-care requisites will be addressed with a focus on the care of adult clients, geriatric clients and their families. Principles of therapeutic interventions, basic conditioning factors, communications and care of the client across the life span will be integrated throughout the course. The role of the provider of care, manager of care, and members within the profession are stressed. Guided clinical experiences are provided concurrently with the theory.

### **503A Advanced Medical-Surgical Nursing (4.5) CSU**

*Prerequisite: Nursing 502B*

*Corequisite: Nursing 507*

*Lecture: 4.5 hours; Lab: 17 hours – 8 week course*

This course utilizes Orem's Self-Care Deficit Theory of Nursing (S-CDTN) and the Nursing Process to focus on health deviation, self-care requisites related to adult clients with multi-system failure in the areas of cardiovascular, respiratory, acute and chronic renal, and neurosensory dysfunctions. Leadership and management skills will be discussed. Developmental self-care requisites will be addressed with a focus on the care of adult clients, geriatric clients and their families. Principles of therapeutic interventions, basic conditioning factors, communications and care of clients across the life span will be integrated throughout the course. The role of the provider of care, manager of care, members within the profession are stressed. Guided clinical experiences are provided concurrently with the theory.

### **503B Psychiatric Nursing (4.5) CSU**

*Prerequisite: Nursing 501B*

*Lecture: 4.5 hours; Lab: 17 hours – 8 week course*

This course utilizes Orem's Self-Care Deficit Theory of Nursing and the nursing process to focus on the care of clients with health deviation self-care requisites in normalcy, solitude and social interaction. The scope of nursing interventions includes supportive/educative, partially compensatory and wholly compensatory actions. Theoretical foci emphasize the concepts of mental health/illness and care of client with mental health and medical/surgical disorders such as: schizophrenia, Mood disorder, Bipolar, Depression, Substance abuse, Dissociative disorders, Anxiety disorders, Eating disorder, Somatoform disorder, Domestic violence, Mental Retardation, Alzheimer's disease, Dementia. Developmental self-care will be address with a focus on the care of adult clients, geriatric clients, children and their caregivers. Principles of therapeutic intervention, basic conditioning factors,

communication and care of the client across the life cycle will be integrated throughout the course. The roles of provider of care, manager of care and member within the profession are stressed. Guided clinical experiences are provided concurrently with theory

### **506A Maternal and Child Health Nursing A (Pediatrics) (4.5) CSU**

*Lecture: 4.5 hours; Lab: 17 hours – 8 week course*

This course utilizes Orem's Self-Care Deficit Theory of Nursing (S-CDTN) and the Nursing Process to focus on health deviation, self-care requisites related to health care needs of children. Emphasis is placed on caring for children with selected problems in fluid and electrolytes, oxygenation, nutrition, Neuromuscular, Musculoskeletal, sensory and regulatory mechanisms. Pediatric clients, from infancy to adolescence, in the context of family, culture, and the community and the nurse's role in education, promotion of child safety, as well as legal issues will be addressed. Principles of therapeutic interventions, basic conditioning factors, and communications will be integrated throughout the course. The role of the provider of care, manager of care, and members within the profession are stressed. Guided clinical experiences are provided concurrently with the theory.

### **506B Maternal and Child Health Nursing B (Obstetrics) (4.5) CSU**

*Prerequisites: Nursing 502A*

*Lecture: 4.5 hours; Lab: 17 hours – 8 week course*

This course utilizes Orem's Self-Care Deficit Theory of Nursing (S-CDTN) and the Nursing Process to focus on health deviation, self-care requisites related to health care needs of women and newborns during the childbearing years. Areas of focus include. Issues in maternity nursing, gynecological nursing Antepartal/Prenatal; Labor and Delivery; Post-Partum; Care of newborn; high risk obstetric conditions. Developmental self-care requisites will be addressed with a focus on the care of women and newborns and their families during the childbearing years. Principles of therapeutic interventions, basic conditioning factors, and communications will be integrated throughout the course. The role of the provider of care, manager of care, and members within the profession are stressed. Guided clinical experiences are provided concurrently with the theory.

### **507 Senior Seminar (1) CSU**

*Lecture: 1 hour*

This course acquaints the student with the influence of important social and economic events on the development of nursing, and the present and future trends in nursing practice and education. Emphasis is placed on the origins and functions of nursing organizations, opportunities for nurses, and community responsibilities. Emphasis is also placed on the legal and ethical issues confronting the nurse in leadership and management styles.

### **517 Mathematics of Drugs and Solutions (3) CSU**

*Lecture: 3 hours*

In this course, after a review of relevant basic mathematics, the student gains knowledge of the systems and techniques used in measuring drug dosages and in computing the preparation of solutions. Included are computation of Pediatric dosages as well as administration of Intra-venous solutions and medications.

### **518 Patient Care Seminar for Transfer**

**Students and LVN to RN Bridge (3) CSU***Lecture: 3 hours*

This course is geared for transfer students and Licensed Vocational Nurses (LVN) needing "Advanced" placement into the ADN program. Emphasis is placed on Orem's Self Care Deficit Theory (The Conceptual Framework for LASC Nursing Program), Role as a Registered Nurse, Professional Nursing Issues, Nursing Communication, Head-Toe Assessment, Pharmacology for Nurse, Concept Map, and the nursing process to develop patient care planning around core nursing fundamentals concepts. Practical application of skills will be ascertained and developed to the level of the course entered.

**520 Orientation to Nursing (1) CSU***Lecture: 1 hour*

This course is designed to assist students interesting in entering the profession of nursing to, explore the profession of nursing, and to evaluate a nursing curriculum. The course allows participants to exam the many fields of nursing and the curriculum module of Los Angeles Southwest College's nursing program. Issues are analyzed that allow students to discuss studies that have examined nursing student's potentials for success or failure in completing a nursing program: They are work issues, family support systems, study skills and self discipline. Students are introduced to support staff, facilities and resources that are available at Southwest College. Assessment Technologies Institute (ATI) on-line testing is introduced. Students engage in discussions of the Los Angeles Southwest College Nursing Department's policies and procedures.

**523 Pharmacology (3) CSU***Lecture: 3 hours*

This course provides an understanding of basic pharmacology standards, policies and regulations involved in the administration of medications. Integrated within the course are concepts of basic math and calculation of drug dosages. The course focuses on drug classifications, pharmacodynamics; chemical interaction; therapeutic, adverse and toxic interactions; and on the use of the Nursing Process in the administration of medications.

**526 Communication in Nursing (1) CSU***Prerequisites: Nursing 501A and 527**Lecture: 1 hour*

This course provides theoretical knowledge, practical application, and experiences with interpersonal communication skills needed to interact therapeutically, institute a teaching-learning plan, and communicate effectively with individuals and groups.

**527 Nursing Process (1) CSU***Corequisite: Nursing 501A**Lecture: 1 hour*

This course introduces the concepts of the nursing process. The nursing program's conceptual framework is also introduced. The nursing process organizes the framework in planning and implementing the practice of patient care. The nursing process and conceptual framework are combined in case studies and client simulations.

**540 Nursing Boot Camp (3) (Pass/No Pass)**

*Enrollment Limitation: Must have been accepted into the Nursing Program, but have not yet taken their first required Nursing course.*

*Lecture: 2 hours; Lab: 3 hours*

This course provides the entering RN students with an overview of client care and management of specialized

skills such as infection control and monitoring of vital signs. It also provides an introduction to nursing theories utilized within the Nursing Program.

**PHILOSOPHY****1 Introduction to Philosophy (3) UC:CSU***IGETC Area 3B**CSUGE Area C2**Lecture: 3 hours*

A survey of the fundamental questions concerning metaphysics, ethics and epistemology. Expected topics will include the nature of what is, the theory of the good, and the sources and limits of human knowledge. Other topics that may be examined from a philosophical perspective include the nature of the self, truth, religion, science, language, beauty and art, justice, social and political theory, and mind.

**8 Deductive Logic (3) UC:CSU***CSUGE Area A3**Lecture: 3 hours*

This is an introductory course in logic. The student is introduced to the standards and techniques of correct thought with regular practice with short specimens of correct and incorrect reasoning taken from daily life. Consistency, thoroughness, and other aspects of rational thought are fostered.

**PHYSICAL SCIENCE****1 Physical Science I (3) UC:CSU***IGETC Area 5A**CSUGE Area B1**Lecture: 3 hours*

Designed for the non-science major, this course provides an introduction to the fundamental principles of physics and chemistry. Elementary quantitative concepts are used to supplement the qualitative emphasis of this course.

**14 Physical Science Laboratory (1) UC:CSU***IGETC Area 5C**CSUGE Area B3**Corequisite: Physical Science 1**Lab: 2 hours*

Designed for the non-science major, this course will provide an introduction to the laboratory methods and skills used in physical science with an emphasis on chemistry and physics.

**PHYSICS****6 General Physics I (4) UC:CSU***IGETC Area 5A, 5C**CSUGE Area B1, B3**Prerequisite: Math 240**Lecture: 3 hours; Lab: 3 hours*

This is a basic course in the mechanics of solids, the mechanics of liquids, molecular physics, and heat. The work includes the solution of problems and laboratory experiments selected to illustrate the major principles of physics.

**7 General Physics II (4) UC:CSU***IGETC Area 5A, 5C**CSUGE Area B1, B3**Prerequisite: Physics 6**Lecture: 3 hours; Lab: 3 hours*

This is a basic course in sound, light, electricity, and magnetism together with an introduction to modern physics.

## 20 Physics Bootcamp (2)

*Prerequisite: Math 241*

*Lecture: 1.5 hours; Lab: 2.5 hours*

The purpose of this course is to prepare students to take the Physics 11 prerequisite challenge test to get into either Physics 1, 6 or 21. The course also prepares students for the higher level physics sequence and provides students with some basic laboratory experience; as such, it is intended to bridge the gap between Physics 11 and the higher level courses and is therefore more rigorous than Physics 11. Students are introduced to Kinematics, Dynamics, Fluid Statics and Dynamics, wave resonance and the Doppler Effect as well as the fields of Thermodynamics, Electricity and Optics. Students use the tools of algebra and trigonometry to analyze a wide variety of content and gain a firm foundation in physics concepts as well as problem solving. Some time is afforded to work out problems in class and ask questions from the homework. On the last day of class, students are given the opportunity of taking the Physics 11 prerequisite challenge test.

## 37 Physics for Engineers and Scientists I (5) UC:CSU

*IGETC Area 5A, 5C*

*CSUGE Area B1, B3*

*Prerequisite: Math 265*

*Lecture: 4 hours; Lab: 3 hours*

Designed for Physics, Astronomy, Chemistry, Engineering & Mathematics majors, This is the first semester of a three semester calculus-level sequence in introductory college Physics. Topics include kinematics, dynamics, laws of motion, and conservation laws for particles and systems of particles in both translation and rotation.

## 38 Physics for Engineers and Scientists II (5) UC:CSU

*IGETC Area 5A, 5C*

*CSUGE Area B1, B3*

*Prerequisites: Math 266 and Physics 37*

*Lecture: 4 hours; Lab: 3 hours*

Designed for Physics, Astronomy, Chemistry, Engineering & Mathematics majors. Topics include mechanical waves, electric charge and electric fields, electric energy storage, electric currents, magnetism, electromagnetic induction, electromagnetic oscillations, AC circuits, and Maxwell's Equations.

## 39 Physics for Engineers and Scientists III (5) UC:CSU

*IGETC Area 5A, 5C*

*CSUGE Area B1, B3*

*Prerequisites: Physics 37*

*Lecture 4 hours; Lab 3 hours*

Designed for Physics, Astronomy, Chemistry, & Engineering majors. Topics include thermodynamics, geometric optics, the wave nature of light, special relativity, early quantum theory, atomic and nuclear physics.

## PHYSIOLOGY

### 1 Introduction to Human Physiology (4) UC:CSU

*IGETC Area 5B, 5C*

*CSUGE Area B2, B3*

*Prerequisites: Biology 3 or 5*

*Lecture: 3 hours; Lab: 3 hours*

This is an introductory course that examines how the human body functions with emphasis on the endocrine,

nervous, cardiovascular, muscular, respiratory, digestive, reproductive and excretory systems. Upon completion of this course the student will be able to describe the major functional characteristics of the human body.

*Note: This course, when taken with ANATOMY 1, is equivalent to BIOLOGY 20.*

## POLITICAL SCIENCE

### 1 The Government of the United States (3) UC:CSU

*IGETC Area 4H*

*CSUGE Area D8*

*Lecture: 3 hours*

An introductory course in the principles, institutions and policy processes of the American political system. An examination of major tenets in Federalism, representative government, and the scope of executive, legislative and judicial powers. It offers an overview of local, state, and national governance.

### 2 Modern World Governments (3) UC:CSU

*IGETC Area 4H*

*CSUGE Area D8*

*Lecture: 3 hours*

This course offers a comparative study of Constitutional principles, governmental institutions, socioeconomic and political dynamics of selected governments abroad.

### 5 The History of Western Political Thought (3) UC:CSU

*CSUGE Area D8*

*Lecture 3 hours*

Examination of various theoretical approaches to politics and of basic political problems and proposed solutions. Analysis of selected political theories and of the relevance of theory to contemporary problems.

### 7 Contemporary World Affairs (3) UC:CSU

*IGETC Area 4H*

*CSUGE Area D8*

*Recommended: Political Science 1*

*Lecture: 3 hours*

This course concentrates on major problems in international relations since World War II, with particular emphasis on current issues in American foreign policy. Specifically, the course examines the causes, consequences, and methods of resolving international conflicts as well as the impact of internal economic, political, and military factors on foreign policy.

### 9 Governments and Politics in Africa (3) UC:CSU

*Lecture: 3 hours*

This course offers a survey of the political and social systems of African countries and their impact on the world, with special reference to traditional Africa, European Colonial policies, slavery, imperialism, nationalism, independence, and the problems of nation-building.

### 19 Women in Politics (3) UC:CSU

*IGETC Area 4D, 4H*

*CSUGE Area D4, D8*

*Lecture: 3 hours*

This course examines political theories and public policies which shape the various possibilities and strategies for women's political participation in the United States and elsewhere. It also examines the political institutions, processes, and problems of the national, state, and local government.



**20 Race and Ethnicity in Politics (3)****UC:CSU***IGETC Area 4C, 4H**CSUGE Area D4, D8**Prerequisite: Political Science 1 and 2**Lecture: 3 hours*

The social construction of racial and ethnic groups in American society and their relationship to local, state and national government are covered. The problems of racism, discrimination and assimilation and the impact of ideology on integration into the political system are covered. In addition the course covers voting behavior and pressure group politics, resistance and political action, the social construction of race and racism, the poor and the culture of poverty. The course also explores the political problems faced by the aged, the young, and women.

**30 The Political Process (3) UC:CSU***Lecture 3 hours*

This class surveys the nature and foundation of the democratic order. Specific focus is placed on traditional democratic theory, the contrasting philosophies surrounding the Framers of the Constitution, and the impact of the decentralized, federal structure on the political processes of the United States.

**41 Principles of Student Leadership (2) CSU***Lecture 3 hours*

This course prepares students in the theory and practice of organizations, leadership, principles of group leadership, and the development of decision making skills. Students taking the course will participate in leadership activities such as student body government, internships, political debates, and more.

**50 Introduction to Research in Political Science (3) UC:CSU***CSUGE Area D8**Lecture 3 hours*

This class considers the logic of the scientific analysis of political and social institutions. Analyzes the various methodological tools utilized in social science research and emphasizes clarification of basic social science issues. Topics include research design, conceptualization, measurement, sampling methodology, instrumentation and both qualitative and quantitative data analysis. Students will analyze specific data collected from existing statistical sources.

**60 Introduction to Globalization (3) UC:CSU***CSUGE Area D8**Lecture 3 hours*

Introduction to the phenomenon of globalization from the broad perspectives of economics, governments and conflicts, and cultures and societies. Structured around these three pillars of globalization, this course is designed to provide a framework for understanding the multiple and complex connections that globalization

**PSYCHOLOGY****1 General Psychology I (3) UC:CSU***IGETC Area 4I**CSUGE Area D9**Lecture: 3 hours*

This is an introductory course in psychology as the scientific study of behavior and mental processes. Topics treated

include history and systems of psychology, biological bases of behavior, sensation and perception, states of consciousness, learning, memory, cognition, personality, human development, motivation and emotion, health and stress, psychological disorders, and therapies.

**2 Biological Psychology (3) UC:CSU***IGETC Area 5B; 5C**CSUGE Area B2; B3**Prerequisite: Psychology 1**Recommended: English 101**Lecture: 3 hours*

The course is about the biological bases of human behavior and as such it deals with the scientific understanding of the relationship between the brain and behavior. The course focuses on how biological mechanisms and brain processes may help explain behavior. Topics covered include the following: issues in biopsychology, nerve cells and nerve impulses, synapses, the nervous system, brain plasticity, sleep, internal regulation, reproductive behaviors, emotional behaviors, learning and memory, language, and psychological disorders.

**3 Personality and Social Development (3) UC:CSU***CSUGE Area E**Prerequisite: Psychology 1**Lecture: 3 hours*

The course is about the biological bases of human behavior and as such it deals with the scientific understanding of the relationship between the brain and behavior. The course focuses on how biological mechanisms and brain processes may help to explain behavior. Topics covered include the following: issues in biopsychology, nerve cells and nerve impulses, synapses, the nervous system, brain plasticity, sleep, internal regulation, reproductive behaviors, emotional behaviors, learning and memory, language, and psychological disorders. Ethical standards for conducting human and animal research as well as invasive and non-invasive experimental research methods are also discussed.

**11 Child Psychology (3) UC:CSU***CSUGE Area D9**Lecture: 3 hours*

This course is concerned with the developmental aspects of the biosocial, cognitive, and psychosocial development of children from pre-birth and infancy to adolescence.

**14 Abnormal Psychology (3) UC:CSU***CSUGE Area D9**Prerequisite: Psychology 1**Lecture: 3 hours*

This course examines historical and current theories concerning the etiology of behavior disorders. Topics include normality, neurosis, psychosis, prevention, and therapy.

**37 Psychology of Codependency and Family Systems (3) CSU***Prerequisite: Psychology 64 and 65**Lecture: 3 hours*

This course deals with chemical dependency and its dysfunctional impact on the family. Also, addiction, co-dependency and related topics are discussed.

**41 Life-Span Psychology: From Infancy to Old Age (3) UC:CSU**

IGETC Area 4I  
CSUGE Area D9; E  
Lecture: 3 hours

This course presents elaboration of developmental aspects of psychosocial, cognitive and physical development, intelligence, personality, self-concept and social roles; tasks, changes and adjustments related to each phase of the life span.

### 43 Principles of Group Dynamics I (3) CSU

Prerequisite: Psych 37

Lecture: 3 hours

This course is an introduction to the dynamics of group interaction with an emphasis upon the individual's first-hand experience as the group studies itself. Under supervision, the factors involved in problems of communication, effective interpersonal skills, and individual growth will be highlighted.

### 63 Alcohol/Drug Studies: Prevention and Education (3) CSU

Lecture: 3 hours

This course deals with strategies used to prevent alcohol and drug problems in different settings including: industry, school, family, and community and rehabilitation centers.

### 64 Introduction to Alcohol and Drug Abuse (3) CSU

Lecture: 3 hours

This is a survey course on alcohol and drug use and abuse. The history, classification, impact, and treatment of psychoactive drugs and drug problems are covered. Public policies and social attitudes on alcohol and drug abuse, as well as mental health and drugs, are also examined.

### 65 Chemical Dependency: Intervention, Treatment, and Recovery (3) CSU

Lecture: 3 hours

This course deals with intervention, treatment and recovery issues in chemical dependency. Intervention issues covered include approached to intervention, obstacles to intervention, and stages of formal intervention. The medical, behavioral, social, and family systems models of treatment, the Alcoholics Anonymous and the rational models of recovery, and various approaches to prevention are also discussed.

### 67 Counseling Techniques for the Chemically Addicted (3) CSU

Lecture: 3 hours

This course deals with substance use/abuse, related theories and counseling techniques that raise awareness in order to bring about change in the chemically addicted individual. Family members and other affected by the addicted individual are also considered in terms of awareness, prevention, and treatment.

### 81 Fieldwork I (3) CSU

Prerequisites: Psychology 1, 37, and 43

Lecture: 1 hour; Lab: 5 hours

This course provides students with practical experience in community agencies providing treatment, counseling or prevention and education programs in the chemical dependency field.

### 82 Fieldwork II (3) CSU

Prerequisite: Psychology 81

Lecture: 1 hour; Lab: 5 hours

This course provides students with the opportunity to strengthen the fieldwork skills of observing, interviewing, evaluating, relating, and reporting that they began to master in Psychology 81.

### 91 Statistics for Psychology (4) CSU

Prerequisites: Psychology 1 and Math 125

Lecture: 3 hours; Lab: 2 hours

This course introduces students to the use of statistical procedures in describing, summarizing, analyzing, interpreting and making inferences about psychological data. Topics covered include: frequency distributions, measures of central tendencies, measures of variability, the standard normal curve, probability, hypothesis testing, correlation and regression, analysis of variance, chi-square and non-parametric procedures.

### 92 Psychological Research Methods (5) CSU

Prerequisites: Psychology 1 and Math 125

Lecture: 5 hours

This course deals with introductory research and measurement concepts, as well as, experimental and non-experimental designs used in behavioral research. Topics covered include ethics in research, developing experimental designs, understanding descriptive, correlational and inferential research results. Students are required to collect and analyze data (using statistical software such as SPSS, Excel etc.) and report research results using APA style.

## READING

### 22 Effective College Reading (3) NDA

Corequisite: English 20A

Lecture: 3 hours

Students improve their abilities to read a variety of texts written at a 7th to 9th grade reading level. They practice identifying topics, main ideas, and supporting details as well as patterns of organization and transitional devices. They also practice summarizing main points of texts in their own words. Increasing students' vocabulary knowledge is another important goal of this course.

### 25 Reading for College Success (3)

Prerequisite: Reading 22

Lecture: 3 hours

Students review reading skills and strategies necessary for college success, including reading for main ideas, determining organizational patterns of details presented, and drawing logical conclusions in paragraphs and short essays. Readings and vocabulary study are in the 9th to 11th grade range. Students are introduced to more critical reading skills (determining author's purpose, tone, point of view, and intended audience) and literary concepts (interpreting figures of speech, characterization, plot, setting, and theme).

### 29 Reading Across the Curriculum (3)

Recommended: English 21 or Reading 25

Lecture: 3 hours

This course provides practice in the reading and study skills most essential for understanding and retaining material in college textbooks. Students read, organize, and summarize selections from college textbooks in a variety of subject areas and have the opportunity to research, synthesize, and reflect on a single topic related to their possible major. Continued vocabulary development is an important aspect of this course. Students focus on learning new words at the 12th grade level, review vocabulary-in-context, and



develop word analysis skills.

### 101 Power Reading (3) CSU

*Prerequisites: English 28 or Reading 25*

*Lecture 3 hours*

Students improve their abilities to read a variety of authors and disciplines appropriate to college level. They will practice critical reading skills, analyzing, summarizing, and evaluating texts. Students will increase their word power, mastering more difficult vocabulary found in college texts.

## REAL ESTATE

### 1 Real Estate Principles (3) CSU

*Lecture: 3 hours*

This course is designed to introduce students to the rules, regulations and requirements for licensing by the Department

of Real Estate (DRE) of the State of California. Students are introduced to terminology, appraisal, contracts, agency responsibilities, finance, escrow and insurance. This course fulfills one of the educational requirements for both the Real Estate Broker's and Salesperson's License Examinations.

### 5 Legal Aspects of Real Estate I (3) CSU

*Prerequisite: Real Estate 1*

*Lecture: 3 hours*

This course is a study of California real estate law, including rights related to property ownership and management, agency, contracts, applications to real estate transfer and conveyances, trust deeds, mortgages, nature of liens, how to acquire title, the eviction process, probate proceedings, real estate agreements, and property taxes. This course fulfills one of the educational requirements for both the Real Estate Broker's and Salesperson's License Examinations.

### 7 Real Estate Finance I (3) CSU

*Prerequisite: Real Estate 1*

*Lecture: 3 hours*

This course stresses the analysis of real estate financing including lending policies and problems in financing transactions in residential, apartment, commercial, and special purpose properties. This course fulfills one of the educational requirements for both the Real Estate Broker's and Salesperson's License Examinations.

### 10 Real Estate Appraisal II (3) CSU

*Lecture: 3 hours*

This advanced appraisal course features a brief review of the theory, principles and methods used in the valuation of residential, commercial and industrial properties. It also features case study problems illustrating the use of the three approaches to value and a thorough analysis of the components utilized by the income approach. This course emphasizes the valuation of all income-producing properties. An appraisal report on an income-producing property is required.

## SOCIOLOGY

### 1 Introduction to Sociology (3) UC:CSU

*IGETC Area 4J*

*CSUGE Area D0*

*Recommended: English 101*

*Lecture: 3 hours*

This introductory course develops the sociological perspective that behavior is determined largely by human interactions and membership in social groups. The main elements of sociological analysis are presented, emphasizing social organization, culture, socialization,

social inequality, and social change and applied to such topics as crime and social delinquency, minorities, the family, religion, education, and urban life.

### 2 American Social Problems (3) UC:CSU

*IGETC Area 4J*

*CSUGE Area D0*

*Recommended: English 101*

*Lecture: 3 hours*

This survey course identifies and analyzes past, present, and future problem areas in the United States. Criteria are developed by which one can evaluate the probable effectiveness of various proposals for change in problem areas such as personal and social disorganization, crime and delinquency, race and ethnic relations, population and urban growth, poverty and social class, war and terrorism.

### 4 Sociological Analysis (3) UC:CSU

*IGETC Area 4J*

*Prerequisites: Sociology 1 and 2*

*Lecture: 3 hours*

This class is an introduction to the scientific study of social phenomena. Topics include research design, conceptualization, measurement, sampling methodology, social research, research skills and both qualitative and quantitative data analysis. Students analyze specific data collected in the field.

### 7 Juvenile Delinquency (3) CSU

*CSUGE Area*

*Recommended: English 28, English 101*

*Lecture: 3 hours*

This course examines the nature of delinquent behavior, stresses, theories of causation of delinquent behavior and of societal reactions to deviant behavior; it also examines methods of crime and delinquency control and places major emphasis on juvenile delinquency.

### 11 Race and Ethnic Relations (3) UC:CSU

*IGETC Area*

*CSUGE Area*

*Prerequisites: Sociology 1 and Sociology 2*

*Recommended: English 28*

*Lecture: 3 hours*

This course emphasizes cultures of the major ethnic and racial groups in the United States; social processes affecting and influencing their adjustment and assimilation and pluralism as dominant trends of American life; and the legal and social solutions to their problems and American public policies.

### 12 Marriage and Family Life (3) CSU

*CSUGE Area E*

*Recommended: English 28*

*Lecture: 3 hours*

This course makes a sociological analysis of the family which contributes to understanding its origin, structure and functions. It aids the student in selecting from available data those factors which are likely to give some practical help to those seeking guidance in the choice of a marriage partner and in the necessary adjustments of marriage and family life. The factors include studies of sex (gender) roles, legal controls, religious attitudes, mixed marriages, financial and family planning and a review of community resources for family counseling and the role of legislation.

### 19 Introduction to the Social Services (3) CSU

*Recommended: English 28*

*Lecture: 3 hours*

This course offers an introduction to the field of social welfare, it includes a socio-historical background and an analysis of how poverty influences welfare policies and practices. Emphasis is placed on the development of social work, including social work education, methods values and ethics. Current social welfare policies and practices of social welfare agencies will be examined.

### **20 Directed Practice in Social Welfare (3) CSU RPT3**

*Prerequisites: Sociology 1 and 19*

*Recommended: English 28*

*Lecture: 3 hours*

Emphasis is placed on providing the students with concept information and practical experience essential for working in the Human and Health field. Students are assigned field work experience in Department of Social Services, probation, drug programs, community mental health centers and other public private agencies.

### **23 Issues of Manhood in US Society (3) CSU**

*Lecture: 3 hours*

This course examines the qualities and responsibilities of men in US society. Issues of masculinity across ethnicities are explored to answer questions of why men act the way they do. Topics include aggression and self-defense; sexuality; fatherhood; and female expectation.

### **45 Sociology of Media and Popular Culture: Examining Hip Hop (3) UC:CSU**

*CSUGE Area D0, D7*

*Prerequisite: Sociology 1*

*Recommended: English 28*

*Lecture: 3 hours*

This course will examine various topics associated with hip hop's evolution, including its socioeconomic roots, its cooption and appropriation, the construction of racial, class and gender identities, media representations, and media framing. The course will draw on a number of theoretical orientations that try to understand popular culture's influence in society. In addition, the course will examine popular culture as an important site where dominant ideology is negotiated and contested, specifically focusing on Black culture as protest and resistance.

## SPANISH

### **1 Elementary Spanish I (5) UC:CSU**

*IGETC Area 6A*

*CSUGE Area C2*

*Lecture: 5 hours*

This course stresses the mastery of fundamentals of pronunciation and structure. Emphasis is placed upon developing the student's ability to understand, to speak, to read, and to write simple Spanish, using a basic vocabulary and stressing idiomatic expressions. The student is introduced to Hispanic culture through simple readings and visual aids.

*study.*

### **2 Elementary Spanish II (5) UC:CSU**

*IGETC Area 3B, 6A*

*CSUGE Area C2*

*Prerequisite: Spanish 1*

*Lecture: 5 hours*

This course is a continuation of Spanish I. It includes the study of verb tenses, various aspects of Hispanic culture based on readings, and an increased amount of time spent

on the development of conversational abilities.

### **3 Intermediate Spanish I (5) UC:CSU**

*IGETC Area 3B, 6A*

*CSUGE Area C2*

*Lecture: 5 hours*

*Prerequisite: Spanish 2*

This course offers a thorough review of Spanish grammar with special emphasis upon idiomatic usage. Continued practice is given in vocabulary building, reading comprehension, conversing with increased proficiency in pronunciation, writing compositions, and the study of Hispanic culture. Included in the course are readings of short stories by well-known writers from both Spain and Latin America with discussions and written reports in Spanish based upon their works.

### **4 Intermediate Spanish II (5) UC:CSU**

*IGETC Area 3B, 6A*

*CSUGE Area C2*

*Prerequisite: Spanish 3*

*Lecture: 5 hours*

This course is a continuation of Spanish 3. Students complete the review of the essential points of Spanish grammar. They increase their vocabulary, expand their ability to converse on a wide range of topics, and enhance their ability to read and understand complex materials in Spanish. Students also write compositions in which they analyze stories. Discussions are held in which students give their interpretations of the stories, explain their symbolism, and defend their view. Students also continue the study of the literature, customs, geography, and history of Spanish-speaking areas.

### **8 Conversational Spanish (2) UC:CSU**

*Prerequisite: Spanish 2*

*Lecture: 2 hours*

This course provides opportunities for students to express themselves fluently and correctly in Spanish using the past, present, and future tenses. Conversation will revolve around everyday topics, current events, and cultural materials. Students will be given opportunities to role-play structured situations in Spanish.

### **14 Spanish for Public Service Personnel (3) CSU**

*Lecture: 3 hours*

This course aids students in developing the ability to express themselves fluently, idiomatically, correctly and effectively in Spanish with specific reference to individual needs in the areas of public service, business and community activities.

### **24 Spanish for Medical Personnel (3) CSU**

*Lecture: 3 hours*

This is a practical, informal oral Spanish course. The course covers material that all professionals in health care will find useful when interacting with people whose preferred, or only, language is Spanish.

## SUPERVISION

### **1 Elements of Supervision (3) CSU**

*Recommended: English 21*

*Lecture: 3 hours*

This introductory course covers in general terms the total responsibilities of a supervisor in industry such as organization, duties and responsibilities, human relations, grievances, training, promotion, quality-quantity control, and management-employee relations.

**4 Supervisor's Responsibility for Management of Personnel (3) CSU***Recommended: English 21**Lecture: 3 hours*

This course covers personnel techniques which will enable the student to carry out his responsibilities as a manager of personnel. The student will explore methods of sound management with respect to selecting, placing, training, counseling, promoting, and related aspects of guiding personnel.

**6 Labor-Management Relations (3) CSU***Prerequisite: Supervision 1**Lecture: 3 hours*

This class considers the logic of the scientific analysis of political and social institutions. Analyzes the various methodological tools utilized in social science research and emphasizes clarification of basic social science issues. Topics include research design, conceptualization, measurement, sampling methodology, instrumentation and both qualitative and quantitative data analysis. Students will analyze specific data collected from existing statistical sources.

**12 Written Communications for Supervisors (3)***Recommended: English 28, English 67**Lecture: 3 hours*

Students learn to improve their writing ability and write professional email messages, memorandums and a wide range of business letters, including direct requests for information, replies to information requests, direct claims, adjustment letters, letters of recommendation, persuasive requests, refusing routine requests and breaking bad news to customers and to employees. This course is one in the series that lead to the college's Certificates in Business Administration, Marketing and Management.

**THEATER****100 Introduction to the Theater (3) UC:CSU***IGETC Area 3A**CSUGE Area C1**Recommended: English 21**Lecture: 3 hours*

This course focuses on the relationship of theatre to various cultures throughout history, and on the contributions of significant individual artists. This course introduces students to elements of the production process including playwriting, acting, directing, design, and criticism. Students will also survey different periods, styles and genres of theatre through play reading, discussion, films and viewing and critiquing live theatre, including required attendance of theatre productions.

**110 History of the World Theater (3) UC:CSU***IGETC Area 3A**CSUGE Area C1**Lecture: 3 hours*

The study of the history of theatre from the Origins of Theatre through the 17th Century. The history and development of theatre and drama are studied in relationship to cultural, political and social conditions of the time. Plays are read for analysis of structure, plot, character and historical relevance.

**114 Script Study for Theatre Performance, Production, and Appreciation (3) CSU***Lecture: 3 hours*

This course provides principles, theories, and techniques of play script analysis for theatrical production.

**130 Playwriting (3) UC:CSU RPT1***Recommended: English 28 or 31**Lecture: 3 hours*

This course will offer students the opportunity to present play ideas and high concepts through formulating a step outline that will be analyzed and criticized. Through class lectures and discussion of text materials, students will attain a deeper knowledge and understanding of the dramatic construction of a play.

**185 Directed Study-Theater (1) CSU***Lecture: 1 hour*

Allows students to pursue Directed Study in Theater on a contract basis under the direction of the supervising instructor.

**231 Play Production (3) UC:CSU***Lab: 9 hours*

In this course the student is involved in the actual preparation for staging a full-length play from the canon of classical theater. The course will cover make-up, costumes, box office procedures, and acting. The course will focus on the technical aspects of organizing a full-length production, with special emphasis on the challenges of a classical production, such as language, speaking in verse, incorporating a chorus, or other elements not often seen in contemporary theater.

**233 Play Production III (3) UC:CSU***Lab: 9 hours*

In this course the student is involved in the actual preparation for staging a full-length play. The course will cover make-up, costumes, box office procedure, and acting. The course will focus on the technical aspects of organizing a full length production.

**240 Voice and Articulation for the Theater (3) UC:CSU***Lecture: 3 hours*

This course is designed as an elementary voice class introducing the student to the mechanics of voice production and the various performance elements of theater and speech: monologues, speeches, the use of vocal quality, tempo and pitch. Through lecture and discussion of technique and of anatomy the course will cover vocal exercise, posture, physical and vocal warmups that will aide the student with acquiring the basics of good voice, speech and articulation for the stage.

**270 Beginning Acting (3) UC:CSU***Lecture: 3 hours*

This course is designed to exercise the separate parts of the composite art of acting which includes thought, preparation, character analysis for monologue and scene preparation. Also, emphasis will be placed on improvisation, cold readings and interpretation. The ultimate goal is to develop a firm foundation for the novice actor in basic acting techniques while being immersed in sensibility to theater history, appreciation and criticism through the presentation of published works.

**271 Intermediate Acting (2) UC:CSU**



*Prerequisite:* Theater 270

*Corequisite:* Theater 291, 292, 293

*Lecture:* 1 hour; *Lab:* 2 hours

This course provides the student an opportunity to further develop the acting skills presented in Beginning Acting and strengthen preparation techniques for monologues and scene presentation. The student will also utilize cold readings and improvisation to further enhance his/her ability to develop a character.

### **291 Rehearsals and Performance (1)**

**UC:CSU**

*Prerequisite:* None

*Lab 3 hours*

This course provides instruction and supervised participation in theatre rehearsal and performance. Students will demonstrate and apply performance and production practices and skills identified and evaluated in the formal classroom. The class will culminate in the production of a play presented before a live audience. Students must be available to meet all scheduled technical rehearsal and performance dates.

### **300 Introduction to Stage Craft (3) UC: CSU**

*Prerequisite:* None

*Lecture:* 3 hours

A study made through lecture and demonstration, of all technical phases of play production including construction, painting, rigging, manipulation of stage scenery, use of lighting equipment, properties, the organization and management of stage activity, and stagecraft terminology.

### **310 Introduction to Theatrical Lighting (3) CSU**

*Prerequisite:* None

*Lecture:* 3 hours

This course involves the study and execution of stage lighting with emphasis on equipment, control, color and their relationship to design.

### **315 Introduction to Theatrical Scenic Design (3) CSU**

*Prerequisite:* None

*Lecture:* 3 hours

Students will be offered a survey of scenery, lighting, sound, costumes, makeup, properties, theatrical equipment and construction techniques through demonstration, and laboratory experience. Information is applicable to all formal theatrical applications.

### **342 Technical Stage Production II (2) CSU**

*Prerequisite:* None

*Lab: 6 hours*

This course provides work in all aspects of play production in terms of study and laboratory practice, including stage management, lighting, sound, special effects, scenic construction, painting, designing, and the use of stage equipment. This course offers practical experience in stage crew and technical production.

### **405 Costume Design (3) CSU**

*Prerequisite:* None

*Lecture:* 3 hours

Students will study costume history, design, and basic construction techniques as an introduction to basic theatrical costuming. Fabrics and their various uses will be investigated.

### **450 Beginning Stage Make-Up (2) CSU**

*Prerequisite:* None

*Lecture:* 1 hour; *Lab 3 hours*

In a lecture and laboratory setting, students will learn techniques and practices for designing and applying makeup for theatrical use, including: glamor, aging, beards, stylized, and fantasy.

## TUTORING (NC)

### **001T Supervised Learning Assistance (0)**

*Prerequisite:* None

*Lab 2 hours*

This course is intended to help students achieve course objectives in the course for which tutoring is recommended. It also helps students to improve learning and study skills through tutoring outside of class time.

## VOCATIONAL EDUCATION (NC)

### **003CE Workplace Readiness-Computers (0)**

*Prerequisite:* None

*Lecture:* 3 hours

This open-entry course introduces students to the computer skills essential to the workplace and educational success. Students will develop word processing skills necessary to create, format and edit common documents and forms. In addition, students will learn the parts and functions of a computer and email management.

### **252CE Exploration of Construction and Maintenance Careers (0)**

*Prerequisite:* None

*Lecture:* 3 hours; *Lab: 3 hours*

This course introduces students to careers, basic skills and common practices in the construction and maintenance industries; helping them discover their aptitudes and interests in the construction field and make more informed decisions about their future careers, education and training. Students will learn and perform basic carpentry, masonry and mechanical skills and tasks. Students will prepare to enter an apprenticeship program in the field of construction or maintenance.



## CONSUMER INFORMATION REQUIREMENTS

[www.lasc.edu/students/consumerinfo.html](http://www.lasc.edu/students/consumerinfo.html)

The Higher Education Act of 1965, as amended by the Higher Education Opportunity Act of 2008 (HEOA), requires institutions participating in federally funded financial aid programs to make information about the institution available to current and prospective students. The LASC Consumer Information Requirements webpage serves to update the Student Right to Know information and provide a central location for resources that can be referenced by parents, students, employees, and the overall Los Angeles Southwest College community. The links and text found at the Consumer Information Requirements webpage provide quick access or reference to various pieces of consumer information. This webpage can be found on the LASC website and will continue to be updated as more information becomes available.

### College Publications

Current College publications include the Academic Affairs Faculty Bulletin, College Catalog, Schedule of Classes, President's Bulletin, Community Services Schedule, and the Student Success Newsletter.

## DISTRICT POLICIES, STUDENT CONDUCT, AND GRIEVANCE/ COMPLAINT PROCEDURES

### DISTRICT POLICIES

#### Federal Educational Rights and Privacy Act (FERPA)

In accordance with the Federal Educational Rights and Privacy Act ("FERPA") (20 U.S.C. 1232g et seq.) and implementing regulations (34 CFR section 99.1 et seq.), each college shall provide the following notice to students on an annual basis.

The Family Educational Rights and Privacy Act (FERPA) affords students the following rights with respect to their educational records:

**1. The right to inspect and review the student's education records which includes discipline records, within 45 days from the date the College receives a request for access.**

Students may submit to the College Admissions

Office written requests that identify the specific record(s) they wish to inspect. Within 45 days, the College Admissions Office will make arrangements for access and will notify the student of the time and place where the records may be inspected.

Education records are those records that are directly related to students and are maintained by the College. Students may not inspect education records pertaining to parents' financial records and certain confidential letters or recommendations.

**2. The right to request an amendment of the student's educational records which the student believes to be inaccurate, misleading, or otherwise in violation of the student's privacy rights.**

With the exception of grade grievances which are handled through Administrative Regulation E-55, students may ask the College President, or his/her designee to amend a record that they believe is inaccurate, misleading, or in violation of their privacy rights. A student seeking to amend an educational record should write to the College President and clearly identify the part of the record he/she wants changed and specify why it is inaccurate, misleading, or in violation of his/her privacy rights.

If the College President, or his/her designee, decides not to amend the record as requested by the student, the College, in accordance with section 99.21 of the Code of Federal Regulations and section 76232 of the Education Code, will notify the student of the decision and of his/her right to a hearing.

**3. The right to consent to disclosures of personally identifiable information contained in the student's educational records, except to the extent that FERPA and California law authorize disclosures without consent.**

If a student authorizes the release of his/her education record to a third party, he/she shall provide a dated written consent to the College Admissions Office authorizing said release with a specific list of the information to be released.

Federal and California law authorize certain disclosures of personally identifiable information without a student's written consent. One such exception is the disclosure of personally identifiable information to school officials with legitimate educational interests. School officials with legitimate educational interests are employees or agents of the Los Angeles

Community College District who need to review educational records in order to fulfill their professional responsibilities.

**4. The right to restrict disclosure of personally identifiable information that the College has designated as directory information which may be released without the written consent of the student.**

Directory information may be disclosed without a student's consent unless the student has notified the college that he/she does not want all or portions of the directory information released. To do so, the student must submit the appropriate District form to the College Admissions Office requesting that some or all of the categories of directory information not be released without his/her consent. This form must be submitted in accordance with College policy.

Pursuant to Board Rule 5201.10, the Los Angeles Community College District has designated the following student information as directory information:

- a) The student's name, address, telephone number, email address, city of residence, participation in officially recognized activities and sports, weight and height of members of athletic teams, dates of attendance, degrees and awards received, and the most previous educational agency or institution attended by the student;
- b) Student employee records may be released in order to comply with collective bargaining agreements;
- c) The names, addresses and telephone numbers of students or former students may be released to the foundation for each college for college-related activities at the discretion of the College President, unless the student or former student has informed the College that such information should not be released. The release of this information is conditioned upon the foundation's agreement that such information will be released in accordance with District policy and that information will not be released to third parties;
- d) At the discretion of the College President, the names, addresses and telephone numbers of students from the College may be released to heads of private and/or public institutions of higher education, or their designees, for the purpose of providing information to students regarding transfer opportunities to those institutions, unless the student has indicated that such information should not be released. The

release of this information will be conditioned upon the institution's agreement that student privacy rights under federal and state law will be protected and that information will not be released to third parties.

**5. The right to file a complaint with the U.S. Department of Education concerning alleged failures by the College to comply with the requirements of FERPA.**

The name and address of the office that administers FERPA is:

Family Policy Compliance Office  
U.S. Department of Education  
400 Maryland Avenue S.W.  
Washington, DC 20202-4605

## STUDENT RIGHTS AND PRIVACY POLICY

The Los Angeles Community College District, in compliance with Federal and State law, has established policies and procedures governing student records and the control of personally identifiable information. The Los Angeles Community College District recognizes that student records are a confidential matter between the individual student and the College. At the same time the District has a responsibility to fulfill public information needs (i.e., information about students participating in athletics, announcement of scholarships and awards, etc.). To meet this responsibility the District may release Directory Information unless the student states in writing that he or she does not want it released. The responsibility for carrying out these provisions is charged to the College Records Officer, designated by the chief administrative officer on each campus. The Records Officer may be contacted via the Office of Admissions. Copies of Federal and State laws and District policies and procedures are maintained by the Records Officer and are available for inspection and inquiry.

All student records maintained by the various offices and departments of the College, other than those specifically exempted by law, are open to inspection by the student concerned. The accuracy and appropriateness of the records may be challenged in writing to the Records Officer. A student has the right to receive a copy of his or her record, at a cost not to exceed the cost of reproduction. (Requests for transcripts should be made directly to the Office of Admissions.)





No student records, other than Directory Information, will be released without the written consent of the student concerned except as authorized by law. A log of persons and organizations requesting or receiving student record information is maintained by the Records Officer. The log is open to inspection only to the student and the community college official or his or her designee responsible for the maintenance of student records.

Directory Information may include the student's name, address, telephone number, email address, city of residence, participation in officially recognized activities and sports, weight and height of members of athletic teams, dates of attendance, degrees and awards received, and the most recent previous educational agency or institution attended by the student. Directory Information about any student currently attending the College may be released or withheld at the discretion of the Records Officer. No Directory Information will be released regarding any student who has notified the Records Officer in writing that such information shall not be released.

All inquiries regarding student records, Directory Information, and policies for records access, release, and challenge should be directed to the Records Officer via the Office of Admissions. Students have the right to file a complaint with the United States Department of Education concerning alleged violations of Federal and State laws governing student records.

## **SEXUAL HARASSMENT POLICY**

The policy of the Los Angeles Community College District is to provide an educational, employment, and business environment free of unwelcome sexual advances, requests for sexual favors, and other verbal or physical conduct or communication constituting sexual harassment. Employees, students, or other persons acting on behalf of the district who engage in sexual harassment as defined in the policy or by state or federal law shall be subject to discipline, up to and including discharge, expulsions, or termination of contract.

## **NO SMOKING POLICY**

Smoking is not permitted in any classroom or other enclosed facility which any student is required to occupy or which is customarily occupied by non-smoking students. Tobacco smoke is known to the State of California to

cause cancer. The college maintains a smoke-free work and educational environment. No Smoking is permitted within any college building or facility.

## **LACCD and LASC Drug-Free Campus**

Los Angeles Southwest College adheres to, supports, and is in full compliance with requirements that maintain our college as a drug-free institution of higher education. The LACCD Board of Trustees has adopted the following standards of conduct: Students and employees are prohibited from unlawfully possessing, using or distributing illicit drugs and alcohol on district premises, in District vehicles, or as part of any activity of the Los Angeles Community College District.

The LACCD Board of Trustees has adopted Rule 9803.19, which prohibits: Any possession of controlled substances which would constitute a violation of Health and Safety Code section 11350 or Business and Professions Code section 4230, any use of controlled substances, the possession of which is prohibited by the same or any possession or use of alcoholic beverages while on any property owned or used by the District or colleges of the District. "Controlled substances," as used in this section, include, but are not limited to the following drugs and narcotics: opiates, opium and opium derivatives, mescaline, hallucinogenic substances, peyote, marijuana, stimulants, depressants, cocaine.

### **Legal Sanctions**

Federal laws regarding alcohol and illicit drugs allow for fines and/or imprisonment. Other legal problems include the loss of driver's license and limitations of career choices.

### **Health Risks**

Health risks associated with the abuse of controlled substances include malnutrition, damage to various organs, hangovers, blackouts, general fatigue, impaired learning, dependency, disability, and death. Both drugs and alcohol may be damaging to the development of an unborn fetus.

### **Other Risks**

Personal problems include diminished self-esteem, depression, alienation from reality, and suicide. Social problems include loss of friends, academic standing and co- and extra- curricular opportunities, alienation from and abuse of family members, and chronic conflict with authority. Economic problems include loss of job,

financial aid eligibility, homes, savings, and other assets.

### **Counseling, Treatment, and Rehabilitation**

Students should contact the LASC Counseling Office for assistance and referrals. LACCD employees who suspect they may have a drug or alcohol problem are encouraged to seek help through the Employee Assistance Program (EAP) before the problem affects their work performance or conduct.

### **Disciplinary Action**

Violation of the above Board Rules shall result in student discipline, imposed in accordance with the Student Code of Conduct, or termination of financial aid; suspension; withdrawal of consent to remain on campus; expulsion subject to reconsideration; and permanent expulsion. Furthermore, institutional policies and practices may impose disciplinary sanctions on students and employees consistent with local, state, and Federal law, up to and including expulsion, termination of employment, and referral for prosecution for violations of the standard of conduct. The Los Angeles Community College District is committed to drug-free and alcohol-free campuses.

Any LACCD employee reporting to work under the influence of alcohol or illegal drugs, or using alcohol or illegal drugs on duty is subject to discipline up to and including dismissal. In addition to disciplinary action by the District, violation of the drug-free policy may be cause for criminal prosecution by government or law enforcement agencies.

### **ACADEMIC FREEDOM STATEMENT**

A student enrolling in one of the Los Angeles Community College District schools may rightfully expect that the faculty and administrators will maintain an environment in which there is freedom to learn. This requires that there be appropriate conditions and opportunities in the classroom and on the campus. As members of the College Community, students should be encouraged to develop the capacity for critical judgment to engage in sustained and independent search for truth and to exercise their rights to free inquiry and free speech in a responsible, non-violent manner.

## STUDENT CONDUCT

### **Instructional Materials**

Students may be required to provide instructional and other materials required for a credit or non-credit course. Such materials shall be of continuing value to a student outside of the classroom setting and shall not be solely or exclusively available from the District.

### **Cell Phone Policy**

1. Students may not use their cell phones to accept or make calls while in class.
2. If cell phones and pagers are brought to class, they must be turned to "silent" or vibration mode.
3. Instructors must review this policy with students at the beginning of the first class period and include it as part of their syllabi.
4. Students who do not adhere to this policy will be asked to leave the class. If it happens a second time, the student may be referred to the Dean of the relevant academic department and may be referred to the Dean of Student Services.

### **Recording Devices, Use of**

Section 78907 of the California Education Code prohibits the use of any electronic listening or recording device without prior consent of the instructor. Any student violating this section is subject to disciplinary action. Any non-student who willfully violates this section is guilty of a misdemeanor.

### **P2P File Sharing (Illegal File Sharing)**

**The following information is based on the Higher Education Opportunity Act/Peer-to-Peer – (HEOA P2P) compliance implementation.** Unauthorized distribution of copyrighted material, including unauthorized peer-to-peer file sharing, may subject students to civil and criminal liability. Civil liability for copyright infringement may include payment of monetary damages to the copyright owner. Criminal penalties for copyright infringement may include fines up to \$250,000 and imprisonment up to ten years. Students who violate the District's computing facilities usage policy (LACCD Administrative Regulation B-28) may also be subject to college disciplinary action, including, but not limited to, suspension or expulsion.

### **Standards of Student Conduct**

A student enrolling in one of the Los Angeles Community Colleges may rightfully expect that the faculty and administrators will maintain an environment in which there is freedom to learn. This requires that there be appropriate conditions and opportunities in the classroom and on the campus. As members of the College Community, students should be encouraged to



develop the capacity for critical judgment to engage in sustained and independent search for truth and to exercise their rights to free inquiry and free speech in a responsible, non-violent manner.

Students shall respect and obey civil and criminal law, and shall be subject to legal penalties for violation of laws of the City, County, State, and Nation.

Student conduct in all of the Los Angeles Community Colleges must conform to District and College rules and regulations. Violations of such rules and regulations, for which students are subject to disciplinary action, include, but are not limited to, the following:

**Board Rule 9701 Instructor's Authority in the Classroom**

Attendance in a classroom shall be limited to duly enrolled students of that class, employees of the District who are authorized to enter the classroom, and authorized visitors to the classroom. The instructor is authorized to order any person not meeting any one of the above requirements from the classroom. Failure of such person or persons to obey this order constitutes a misdemeanor.

**Board Rule 9803.10 Willful Disobedience**

Willful disobedience to directions of College officials acting in the performance of their duties.

**Board Rule 9803.11 Violation Of College Rules And Regulations**

Violation of College rules and regulations including those concerning student organizations, the use of College facilities, or the time, place, and manner of public expression or distribution of materials.

**Board Rule 9803.12 Dishonesty**

Dishonesty, such as cheating, or knowingly furnishing false information to the College.

**Board Rule 9803.13 Unauthorized Entry**

Unauthorized entry to or use of the College facilities.

**Board Rule 9803.14 College Documents**

Forgery, alteration, or misuse of college documents, records, or identification.

**Board Rule 9803.15 Disruption Of Classes**

Obstruction or disruption of classes, administration, disciplinary procedures, or authorized College activities.

**Board Rule 9803.16 Theft Of Or Damage To Property**

Theft of or damage to property belonging to the College, a member of the College Community, or a campus visitor.

**Board Rule 9803.17 Interference With Peace Of College**

The malicious or willful disturbance of the peace or quiet of any of the Los Angeles Community Colleges by loud or unusual noise or any threat, challenge to fight, fight, or violation of any rules of conduct. Any conduct which violates this section shall be considered to have interfered with the peaceful conduct of the activities of the college where such acts are committed.

**Board Rule 9803.18 Assault Or Battery**

Assault or battery, abuse, or any threat of force or violence directed toward any member of the College Community or campus visitor engaged in authorized activities.

**Board Rule 9803.19 Alcohol And Drugs**

Any possession of controlled substances which would constitute a violation of Health and Safety Code section 11350 or Business and Professions Code section 4230, any use of controlled substances the possession of which are prohibited by the same, or any possession or use of alcoholic beverages while on any property owned or used by the District or colleges of the District. "Controlled substances," as used in this section, include but are not limited to the following drugs and narcotics:

- Opiates, opium, and opium derivatives
- Mescaline
- Hallucinogenic substances
- Peyote
- Marijuana
- Stimulants and depressants
- Cocaine

**Board Rule 9803.20 Lethal Weapons**

Possession, while on a college campus or at a college-sponsored function, of any object that might be used as a lethal weapon is forbidden by all persons except sworn peace officers, police officers, and other governmental employees charged with policing responsibilities.

**Board Rule 9803.21 Discriminatory Behavior**

Behavior while on a college campus or at a college-sponsored function, inconsistent with the District's Non-discrimination Policy, which requires that all programs and activities of the Los Angeles Community College District be operated in a manner which is free of "Prohibited Discrimination," defined as discrimination or

harassment in violation of state or federal law on the basis of actual or perceived ethnic group identification, race, color, national origin, ancestry, religion, creed, sex (including gender-based sexual harassment), pregnancy, marital status, cancer-related medical condition of an employee, sexual orientation, age, physical or mental disability, or veteran status.

**Board Rule 9803.22 Unlawful Assembly**

Any assemblage of two or more persons to 1) do an unlawful act, or 2) do a lawful act in a violent, boisterous, or tumultuous manner.

**Board Rule 9803.23 Conspiring To Perform Illegal Acts**

Any agreement between two or more persons to perform illegal acts.

**Board Rule 9803.24 Threatening Behavior.**

A direct or implied expression of intent to inflict physical or mental/emotional harm and/or actions, such as stalking, which a reasonable person would perceive as a threat to personal safety or property. Threats may include verbal statements, written statements, telephone threats, or physical threats.

**Board Rule 9803.25 Disorderly Conduct.**

Conduct which may be considered disorderly includes: lewd or indecent attire or behavior that disrupts classes or college activities; breach of the peace of the college; aiding or inciting another person to breach the peace of college premises or functions.

**Board Rule 9803.26 Theft or Abuse of Computer Resources.**

Theft or abuse of computer resources including but not limited to:

- a. Unauthorized entry into a file to use, read, or change the contents, or for any other purpose.
- b. Unauthorized transfer of a file.
- c. Unauthorized use of another individual's identification and password.
- d. Use of computing facilities to interfere with the work of a student, faculty member, or college official, or to alter college or district records.
- e. Use of unlicensed software.
- f. Unauthorized copying of software.
- g. Use of computing facilities to access, send, or engage in messages which are obscene, threatening, defamatory, present a clear and present danger, violate a lawful regulation, and/or substantially disrupt the orderly operation of a college campus.

- h. Use of computing facilities to interfere with the regular operation of the college or district computing system.

**Board Rule 9803.27 Performance of an Illegal Act.**

Conduct while present on a college campus or at a location operated and/or controlled by the District or at a District sponsored event, which is prohibited by local, state, or federal law.

**Board Rule 9803.28 Academic Dishonesty.**

Violations of Academic Integrity include, but are not limited to, the following actions: cheating on an exam, plagiarism, working together on an assignment, paper, or project when the instructor has specifically stated students should not do so, submitting the same term paper to more than one instructor, or allowing another individual to assume one's identity for the purpose of enhancing one's grade.

**Board Rule 9804 Interference With Classes**

Every person who, by physical force, willfully obstructs, or attempts to obstruct, any student or teacher seeking to attend or instruct classes at any of the campuses or facilities owned, controlled, or administered by the Board of Trustees of the Los Angeles Community Colleges District, is punishable by a fine not exceeding five hundred dollars (\$500) or imprisonment in a county jail not exceeding one year or by both such fine and imprisonment. As used in this section, "physical force" includes, but is not limited to, use of one's person, individually or in concert with others, to impede access to or movement within or otherwise to obstruct the students or teachers of the classes to which the premises are devoted.

**Board Rule 9805 Interference With Performance Of Duties By Employees**

Every person who attempts to cause, or causes, any officer or employee of any of the Los Angeles Community Colleges or any public officer or employee to do or refrain from doing, any act in the performance of his/her duties, by means of a threat to inflict any injury upon any person or property, is guilty of a public offense.

**Board Rule 9805.10 Assault Or Abuse Of Instructor**

Every parent, guardian, or other person who assaults or abuses any instructor employed by the District in the presence or hearing of a community college student or in the presence of other community college personnel or students and at a place which is on District premises or public sidewalks, streets, or other public ways



adjacent to school premises or at some other place where the instructor is required to be in connection with assigned college activities is guilty of a misdemeanor.

#### **Board Rule 9806. Unsafe Conduct**

Conduct which poses a threat of harm to the individual and/or to others. This includes, but is not limited to, the following types of conduct:

- 1) Unsafe conduct in connection with a Health Services Program (e.g., Nursing, Dental Hygiene, etc.);
- 2) Failure to follow safety directions of District and/or College staff;
- 3) Willful disregard of safety rules as adopted by the District and/or College; and/or
- 4) Negligent behavior which creates an unsafe environment.

#### **Board Rule 9901 Colleges As Non-Public Forums**

The colleges of the Los Angeles Community College District are non-public forums, except for those portions of each college designated as Free Speech Areas by their respective college presidents. The Free Speech Areas are hereby designated as limited public forums, which designation may be removed and reverted to non-public forum designation by the Board of Trustees.

#### **Board Rule 9902 Free Speech Areas**

The College President shall designate an area or areas on the college campus as areas for free discussion and expression by all persons. A Free Speech Area may only be located where there is a normal flow of student traffic with unlimited accessibility. Necessary campus rules governing the operation of such areas are to be used. All such rules shall be applied equally and fairly to all persons desiring to use the Free Speech Areas. No restrictions shall be placed on subject matter, topics, or viewpoints expressed in Free Speech Areas.

#### **Board Rule 9902.10 Responsibilities Of Persons Using Free Speech Areas**

All persons using the Free Speech Area of a college are expected to monitor the content of their speech such that the expression (1) is not obscene, libelous, or slanderous according to current legal standards, (2) does not create a clear and present danger of the commission of unlawful acts on community college premises, (3) is not violative of lawful community college regulations, or (4) does not substantially disrupt the orderly operation of the college. Any person who is found to have expressed speech in violation of this section may be subject to the

sanctions applicable respectively to students, staff, faculty, or visitors.

#### **Board Rule 9902.11 Distribution Of Materials**

Persons using a Free Speech Area shall be allowed to distribute petitions, circulars, leaflets, newspapers, miscellaneous printed matter, and other materials, subject to the following restrictions:

- 1) Such distribution shall take place only within the geographical limits of the Free Speech Area;
- 2) Any material being distributed which is discarded or dropped in or around the Free Speech Area other than in an appropriate receptacle must be retrieved and removed or properly discarded by those persons distributing the material prior to their departure from the Free Speech Area that day;
- 3) Persons distributing material shall not impede the progress of passers-by into taking the offered material.

#### **Board Rule 9902.12 Forms Of Speech**

Persons using a Free Speech Area shall be entitled to exercise their speech privileges in any manner which does not violate the rules of conduct set forth in Article VIII or in the Article, including but not limited to the use of printed materials and the wearing of buttons, badges, or other insignia, except that:

- 1) No means of amplification may be used, electronic or otherwise, which creates any noise or diversion that disturbs or tends to disturb the orderly conduct of the campus or classes taking place at the time;
- 2) No person using the Free Speech Area shall physically touch, strike, or impede the progress of passers-by, except for incidental or accidental contact, or initiate such contact with a passers-by;
- 3) No person using the Free Speech Area shall solicit donations of money, through direct requests for funds, sales of tickets, or otherwise, except where he/she is using the Free Speech Area on behalf of and collecting funds for an organization which is registered with the Secretary of State as a non-profit corporation, or is an approved Association Student Organization which is registered with the Secretary of State as a non-profit corporation, or is an approved Associated Student Organization or Club.

#### **Board Rule 9902.13 Time Allotments For Speech**

The president of each college or his/her representative may set reasonable time restrictions on the use of Free Speech Areas, in order to ensure that all persons are given equal



access to the use of the Free Speech Area. If it appears to the president or his/her representative that granting extra time to a person for the use of the Free Speech Area will not impair equal access to the forum for all interested persons, such extra time shall be granted.

Access to the Free Speech Area shall be granted on a weekly schedule on a first-come, first-served basis; however, priority shall be given to any person who has not yet used the Free Speech Area during a week over any persons who have already used the forum during that week. The times at which the Free Speech Area may be used shall be subject to reasonable campus regulations.

#### **Board Rule 9903 Student Exercise Of Free Speech In Areas Outside Of Designated Free Speech Area**

The president of each college may designate areas outside of the Free Speech Areas where students, faculty, and staff may exercise freedom of expression subject only to reasonable time, place, and manner restrictions.

#### **Board Rule 9903.10 Bulletin Boards**

Students shall be provided with bulletin boards for use in posting student materials at campus locations convenient for student use. The location and number of such bulletin boards shall be determined by the College President or his/her representative. Each college may have bulletin boards. The use of the bulletin boards shall be open to use only by students or recognized student organizations and shall be based on a first-come, first-served basis. Posting of materials on bulletin boards shall be subject to the limitations concerning the manner of exercising students' right of free expression in Free Speech Areas pursuant to Section 9902.10 All material displayed shall clearly indicate the author or agency responsible for its production and shall be dated with the date of posting by the College President's designee. The president of each college shall prescribe reasonable lengths of time during which such printed material may be posted on the bulletin boards with the object of assuring fair access to the bulletin boards for all students.

#### **Board Rule 9903.11 Posting Areas**

The president of each college, or his/her representative, may designate areas other than the bulletin boards for display of material.

#### **Board Rule 9904 Student Use Of Areas Not Designated For Free Speech Activities**

Student use of classrooms, rooms, buildings,

facilities, and grounds not designed as Free Speech Areas or otherwise designated for student free speech exercises in accordance with this article shall be governed by the rules and regulations established pursuant to Article X, relating to student activities and events.

#### **Board Rule 9905 Visitor Use Of Areas Not Designated For Free Speech Activities**

Visitor use of any areas, classrooms, rooms, buildings, facilities, and grounds not designated as Free Speech Areas is subject to the Civic Center Permit rules set forth in Chapter VII, Article 2 of these Board Rules.

#### **Board Rule 91001 Application Of This Article To Non-Free Speech Areas**

Events and activities conducted on a college campus by students or Associated Student Organization clubs or groups which do not take place in any area designated for student free speech by the president of the college pursuant to Article IX shall be governed by the rules set forth in this Article.

#### **Board Rule 91002 President's Authority To Create Additional Rules**

The president of each college may adopt and approve rules not set forth in these rules for the purpose of governing the use of the college's facilities. The president shall not approve any rules which are inconsistent with this Article.

#### **Board Rule 91003 Fund-Raising Events For Non-Profit Purposes**

A college or student body participating with outside organizations in non-profit fund-raising events such as membership drives, merchandising sales, book collections, or other events when the public is asked to contribute, or solicited to purchase tickets or any merchandise, shall ascertain that the organization is registered with the Secretary of State as a non-profit corporation.

#### **Board Rule 91004 Speakers To Campus Groups**

The president of each college shall establish regulations regarding the appearance of visiting speakers in accordance with the following regulations.

#### **Board Rule 91004.10 Guest Lecturers**

An instructor may invite an individual to participate in his/her class as a guest lecturer. The instructor shall give prior written notice identifying the speaker to the college president or his/her designated representative.

#### **Board Rule 91004.11 Lecturers And Speakers**

**At Student-Sponsored Forums**

Recognized student organizations may invite and hear persons of their own choosing, provided they give prior written notice identifying the speaker to the College President or his/her designated representative.

**Board Rule 91004.12 Non-Censorship Of Lecturers And Speakers**

Those routine procedures required by an institution before a guest speaker is invited to appear on campus shall be designed only to ensure that there is an orderly scheduling of facilities and adequate preparation for the event and that the occasion is conducted in a manner appropriate to an academic community. The institutional control of campus facilities shall not be used as a device of censorship. It shall be made clear to the academic and larger community that sponsorship of guest speakers does not necessarily imply approval or endorsement of the views expressed, either by the sponsoring group or the institution.

**Board Rule 91005 Applicability Of Free Speech Rights**

All free speech rights accorded students in Article IX shall be accorded them in activities conducted under this Article; the College President shall not approve any rules relating to non-Free Speech Areas which would deny students their free speech rights were they conducting such activities in Free Speech Areas.

**Board Rule 91204. Non-Student on Campus Without Lawful Business Thereon.**

Any person who is not a student, officer, or employee of the District, or one who is not required by his/her employment to be on a campus or any other facility owned, operated, or controlled by the Board of Trustees, shall not be allowed on any campus or any facility owned, operated, or controlled by the Board of Trustees, unless he/she has lawful business thereon. "Lawful business" means a reason for being present which is not otherwise prohibited by statute, by ordinance, or by regulation adopted pursuant to statute or ordinance.

**STUDENT DISCIPLINE PROCEDURES**

Community college districts are required by law to adopt standards of student conduct along with applicable penalties for violation (Education Code Section 66300). The Los Angeles Community College District has complied with this requirement by adopting Board Rule 9803, Standards of Student Conduct. The District has

adopted Board Rule 91101, Student Discipline Procedures, to provide uniform procedures to assure due process when a student is charged with a violation of the Standards of Student Conduct. All proceedings held in accordance with these procedures shall relate specifically to an alleged violation of the established Standards of Student Conduct. These provisions do not apply to grievance procedures, student organization councils and courts, or residence determination and other academic and legal requirements for admission and retention. Disciplinary measures may be taken by the College independently of any charges filed through civil or criminal authorities, or both. Copies of the Student Discipline Procedures are available in the Office of Student Services.

**GRIEVANCE AND COMPLAINT PROCEDURES****Grade Grievance Procedure**

Grievances pertaining to grades are subject to the California Education Code Section 76224 (a) which states: "When grades are given for any course of instruction taught in a community college district, the grade given to each student shall be the grade determined by the instructor of the course and the determination of the student's grade by the instructor, in the absence of mistake, fraud, bad faith, or incompetence, shall be final."

The grievance procedure does not apply to the challenge process for prerequisites, corequisites, advisories, and limitation on enrollment; actions dealing with student discipline; appeal of residency decisions; or eligibility, disqualification, or reinstatement of financial aid. The appeal procedure for eligibility, disqualification, or reinstatement of financial aid may be obtained in the Financial Aid Office.

Complaints involving discrimination such as sexual harassment, ethnic group discrimination, religion, age, gender, color, sexual orientation, and physical or mental disability discrimination are covered under different procedures. Please see the College Catalog sections on Sexual Harassment and/or Equal Opportunity Policy, or contact the District Office of Diversity Programs at (213) 891-2315.

**Student Process for Filing Complaints Regarding Grades**

**Step 1:** Consult the Instructor for resolution.

**Step 2:** Confer with the Department Chair as



second level of authority if issue is not resolved.

**Step 3:** Make an appointment with the Dean of the relevant academic department if there is no resolution at Levels 1 or 2

**Step 4:** The Dean of the relevant academic department may refer the student to the Dean of Student Services or to the Vice President if there is no resolution at Level 3.

**Step 5:** Further referral may be to the LASC Compliance Officer.

For assistance and information regarding the Student Grievance Procedure, contact the LASC Compliance Officer, Dr. Howard Irvin in the Student Services Building, Room 209, or by telephone at (323) 241-5328.

### **Academic Disability Accommodation Grievance Procedures**

Every effort will be made to resolve the matter through the informal process. The student should schedule a meeting with the person(s) involved in the dispute, as well as the person's immediate supervisor, the corresponding Dean of Academic Affairs/Student Services, and a Disabled Students Program & Services (DSPS) professional.

In situations when an agreement cannot be reached informally, the student may file a written request for a formal hearing with the LASC Compliance Officer/Dean of Student Services. An Academic Accommodations Review Committee will be selected to review the grievance. The panel will include two faculty members, two administrative members, and the DSPS Coordinator or designee (non-voting). If the student is dissatisfied with the Academic Accommodations Panel's decision, he/she may appeal to the College President.

The student may also file a formal discrimination complaint with the LASC Compliance Officer who will then follow the established steps outlined Chapter XV of the LACCD Board Rules. The LASC Compliance Officer can be reached at (323) 241-5328 or at the Dean of Student Services Office at Los Angeles Southwest College, 1600 West Imperial Highway, Los Angeles, CA 90047.

The student still has the right of external appeal to the Office for Civil Rights under Section 504 of the Rehabilitation Act of 1973. Contact information: V: 1-800-421-3481 TTY: 1-877-521-2172. [The US Department of Education Office for Civil Rights](#) offers guidance on how to file a

discrimination complaint with the Office for Civil Rights.

### **Equal Opportunity Policy Compliance Procedure**

See District Policies section for details.

### **Sexual Harassment Complaint Procedure**

See District Policies section for details.

## **OTHER INFORMATION**

### **Role of the LASC Compliance Officer**

The LASC Compliance Officer acts as first contact for student and faculty/staff complaints dealing with alleged sexual harassment, academic disability accommodation complaints, or with age, gender, race or ethnic group discrimination. The LASC Compliance Officer can be reached at (323) 241-5328. The LASC Compliance Officer may work with the District Office of Diversity Programs to resolve complaints according to established procedures and LACCD Board Rules.

### **Role of the LASC Ombudsperson**

The president of LASC appoints an Ombudsperson to assist students with their grievances (i.e. grades, discipline, etc.). The Ombudsperson facilitates the grievance procedure and assists students to resolve their grievances. The Ombudsperson also will arrange for a Student Grievance Hearing Committee to hear a student grievance when appropriate and arrange for the assistance of a Student Advocate as needed. The Ombudsperson, Dr. Irvin Howard, can be reached at (323) 241-5328.

### **LACCD Office of Diversity Programs**

The District Office of Diversity Programs and the LACCD Compliance Officers handle complaints dealing with alleged sexual harassment; age, gender, race or ethnic group discrimination; and grade disputes. The District Office of Diversity Programs can be reached at (213) 891-2315.

### **Student Complaint Procedure for Issues Not Resolved at the Campus Level**

LASC and LACCD Student Grievance and Complaint Procedures are established so that students can resolve difficulties/problems they encounter in college-related activities. Most complaints, grievances, or disciplinary matters





should be resolved at the campus level. This is the quickest and most successful way of resolving issues involving a California Community College (CCC). Students are encouraged to work through the LASC complaint process first, before escalating issues to any non-LASC resources.

In accordance with federal regulations, the California Community College Chancellor's Office (CCCCO) administers a state-level complaint process. This is so students and others have a method and process outside of the institution that takes, investigates, and responds to complaints regarding the institution.

Visit the California Community College Chancellor's Office Complaint Process web-page at <http://californiacommunitycolleges.cccco.edu/ComplaintsForm.aspx> and follow the instructions there to present a complaint to:

- The [Accrediting Commission for Community and Junior Colleges \(ACCJC\)](http://www.accjc.org/complaint-process) at <http://www.accjc.org/complaint-process> if your complaint is associated with the institution's compliance with academic program quality and accrediting standards. The ACCJC can also be contacted via mail (The Accrediting Commission for Community and Junior Colleges Western Association of Schools and Colleges, 10 Commercial Boulevard, Suite 204, Novato, CA 94949), or by phone (415.506.0234), fax (415.506.0238), or email ([accjc@accjc.org](mailto:accjc@accjc.org)). ACCJC is the agency that accredits the academic programs of the California Community Colleges.
- To the [CCC Chancellor's Office Complaints Form](http://californiacommunitycolleges.cccco.edu/ComplaintsForm.aspx) at <http://californiacommunitycolleges.cccco.edu/ComplaintsForm.aspx> if your complaint does not concern CCC's compliance with academic program quality and accrediting standards.
- To the [CCC Chancellor's Office Legal Affairs website](http://www.cccco.edu/ChancellorsOffice/Divisions/Legal/Discrimination/tabid/294/Default.aspx) at <http://www.cccco.edu/ChancellorsOffice/Divisions/Legal/Discrimination/tabid/294/Default.aspx> if your complaint involves unlawful discrimination.

## GLOSSARY

**ACADEMIC PROBATION** — After attempting 12 units, a student whose cumulative grade-point-average (beginning Fall 1981) falls below 2.00 is placed on academic probation. A student whose cumulative grade point average falls below 2.00 for two consecutive semesters is subject to dismissal from the college.

**ACADEMIC RENEWAL** - Removal from a student's academic record, for the purpose of computing the grade point average, previously recorded substandard academic performance which is not reflective of the student's demonstrated ability.

**ADD PERMIT** - A card issued by an instructor upon presentation of a valid ID Card which permits the student to add the class if the instructor determines that there is room. Enrollment in the class is official only if the Add Permit is processed by Admissions & Records before the published deadline.

**ADMISSIONS AND RECORDS** - The office which admits a student and certifies his/her legal record of college work; also provides legal statistical data for the college.

**ADMINISTRATION** - Officials of the College who direct and supervise the activities of the institution.

**APPEAL** - A student request for reconsideration of a decision made affecting disciplinary action, grade change, prerequisite challenge, etc.

**APPLICATION FOR ADMISSION** - A form provided by the college in person or online on which the student enters identifying data and requests admittance to a specific semester or session. A student may not register and enroll in classes until the application has been accepted and a Permit to Register issued.

**ASO** - Organization to which all enrolled students are eligible to join is called the Associated Students Organization.

**ASSESSMENT OF LEARNING**—Learning assessment refers to a process where methods are used to generate and collect data for evaluation of courses and programs to improve educational quality and student learning. This term refers to any method used to gather evidence and evaluate quality and may include both quantitative and qualitative data in instruction or student services.

**ASSOCIATE DEGREE (AA OR AS)** - A degree (Associate in Arts or Associate in Science) granted by a community college which recognizes a student's satisfactory completion of an organized program of study consisting of 60 to 64 semester units.

**ATTENDANCE** - "Attendance" means attendance in at least one semester each calendar year. Los

Angeles Southwest College defines continuous attendance for the California community colleges as attendance in one semester during the calendar year before the current semester of enrollment. (Two semesters need not be consecutive, as long as they are in the same calendar year.) Attendance means enrollment and completion of graded academic course work. (CR, NCR, I, and W are acceptable.) Summer is not included in continuous attendance.

**AUDIT** - A student's attendance in a class with permission of the instructor and payment of a fee. Neither college credit nor a grade is given.

**AUTHENTIC ASSESSMENT**—Traditional assessment includes methods such as multiple choice questions focusing on content or facts. In contrast, authentic assessment simulates a real world experience by evaluating the student's ability to apply critical thinking and knowledge or to perform tasks that may approximate those found in the work place or other venues outside of the classroom setting.

**BACHELOR'S DEGREE (B.A., A.B., B.S.)** - A degree granted by a four-year college or university which recognizes a student's satisfactory completion of an organized program of study consisting of 120 to 130 semester units.

**CalWORKs** - California Work Opportunities and Responsibilities to Kids.

**CAREER EDUCATION CERTIFICATE** - A certificate granted by a community college which recognizes a student's satisfactory completion of an organized program of vocational study of approximately 16 to 45 units.

**CAREER PROGRAM** - A group of courses planned to lead to competency in a particular field of study leading to either a Career/Skill Certificate or an Associate Degree.

**CLASS SECTION** - A group of registered students meeting to study a particular course at a definite time. Each section has a ticket number listed in the Schedule of Classes before the scheduled time of class meeting.

**CLASS SECTION NUMBER** - A number used to identify a specific section of a class; also called a Ticket Number.

**COMMUNITY COLLEGE** - A two-year college offering a wide range of programs of study, many determined by local community need.

**CONCURRENT ENROLLMENT** - Enrollment in two or more classes at two or more colleges during the same semester.

**CONCURRENT ENROLLMENT (K-12)** - Enrollment in both high school and college classes.

**CONTINUING STUDENT** - A student registering



for classes who attended the College during the fall or spring semester of the previous academic year. A student registering for the fall semester is a continuing student if he or she attended the College during the previous spring or fall semesters; attendance during the summer session is not included in this determination.

**COREQUISITE** - A requirement that must be satisfied at the same time a particular course is taken; usually a corequisite is concurrent enrollment in another course.

**COUNSELING** - Guidance provided by professional counselors in collegiate, vocational, social, and personal matters.

**COURSE** - A particular portion of a subject selected for study. A course is identified by a subject Title and Course Number; for example: Accounting 1.

**COURSE TITLE** - A phrase descriptive of the course content; for example, the course title of Accounting 1 is Introductory Accounting I.

**CREDIT BY EXAMINATION** - Course or unit credit granted for demonstrated proficiency through testing.

**DIRECTORY INFORMATION** - Directory information may include the student's name, address, telephone number, email address, city of residence, participation in officially recognized activities and sports, weight and height of members of athletic teams, dates of attendance, degrees and awards received, the most previous educational agency or institution attended by the student.

**DISMISSAL** - A student on academic or progress probation may be dismissed from the college. Once dismissed the student may not attend any college within the Los Angeles Community College District for a period of one year and must petition for readmittance at the end of that period of time.

**EDUCATION PROGRAM** - A planned sequence of credit courses leading to an Associate Degree or a Skills Certificate.

**ELECTIVES** - Courses which a student may choose without the restriction of a particular major program-curriculum.

**ENL** - English as a native language

**ENROLLMENT** - That part of the registration process during which a student selects classes by ticket number to reserve a seat in a selected class and is placed on the class roster. A student may also enroll in a class by processing an Add Permit obtained from the instructor of the class.

**ESL** - English as a second language

**FULL-TIME STUDENT** - A student may be verified as a full-time student if he/she is enrolled and active

in 12 or more units during the Fall or Spring semester.

**GENERAL EDUCATION REQUIREMENTS** - (also called Breadth Requirements). A group of courses selected from several disciplines which are required for graduation.

**GRADE POINTS** - The numerical value of a college letter grade: A-4, B-3, C-2, D-1, F-0.

**GRADE-POINT-AVERAGE** - A measure of academic achievement used in decisions on probation, graduation, and transfer. The GPA is determined by dividing the total grade points earned by the number of units attempted.

**GRADE POINTS EARNED** - Grade points times the number of units for a class.

**HYBRID COURSE** - If one or more class sessions (up to 50%) is replaced with online content and/or activities, it is considered a Hybrid course. A Hybrid course can utilize features of the Learning Management System, such as Course Documents, Discussion Boards, Virtual Classrooms, Groups, Assignments, External Links, Digital Drop Boxes and Grade Books, etc. The course can be offered during regularly scheduled class times or with Online components that replace some of the regularly scheduled class meetings.

**I - INCOMPLETE.** The administrative symbol "I" is recorded on the student's permanent record in situations in which the student has not been able to complete a course due to circumstances beyond the student's control. The student must complete the course within one year after the end of the semester or the "I" reverts to a letter grade determined by the instructor. Courses in which the student has received an Incomplete (I) may not be repeated unless the "I" is removed and has been replaced by a grade of "D" or "F." This does not apply to courses which are repeatable for additional credit.

**INSTITUTIONAL LEARNING OUTCOMES** - Institutional learning outcomes, or institutional SLOs, are the knowledge, skills, and abilities a student is expected to leave an institution with as a result of a student's total experience. These outcomes may also be equated with GE (General Education) outcomes.

**INTERSESSION** - Refers both to classes offered during the break between fall and spring semesters (winter session) or in the summer (summer session).

**IP** - In Progress. An "IP" is recorded on the student's permanent record at the end of the first semester of a course which continues over parts or all of two semesters. The grade is recorded at the end of the semester in which the course ends.

**LOWER DIVISION** - Courses at the freshman and sophomore level of college.

**MAJOR** - A planned series of courses and activities selected by a student for special emphasis which are designed to teach certain skills and knowledge.

**STUDENT SUCCESS AND SUPPORT PROGRAM (formerly Matriculation)** - A combination of assessment of reading, writing, and mathematics skills; orientation to college programs and services; academic advising and counseling; and the programs and services that enable a student to reach his or her educational goals.

**MINOR** - The subject field of study which a student chooses for secondary emphasis.

**MODULE** - A portion of a parent course offered for the benefit of students who do not wish to attempt the work of the entire course in one semester. Students should, when possible, attempt to complete all modules of a parent course in one year. A module is identified by a letter in the course number field.

**NCR** - No credit

**NDA** - Non degree applicable

**NP** - No Pass

**NON-PENALTY DROP PERIOD** - The first two weeks of a regular semester during which a student's enrollment in a class is not recorded on the student's permanent record if the student drops by the deadline. This deadline will be different for short-term and summer session courses.

**ONLINE CLASS** - An Online course is offered 100% online. Students cannot be required to attend a physical classroom when participating in an online course. An online course shall utilize features of the Learning Management System, such as Course Documents, Discussion Boards, Virtual Classrooms, Groups, Assignments, External Links, Digital Drop Boxes and Grade Books, etc. All course instruction, materials, assignments, and discussions are posted and done online. Online courses require of the student and instructor the same amount of course work and hours outside of the classroom as traditional courses;

**ONSITE CLASS** - A class taught in the traditional way in a physical classroom.

**PARENT COURSE** - A course which may be offered in modules. Credit for all modules of a parent course is equivalent to credit for the parent course. Parent courses are all courses without letters in the course number field.

**PASS/NO PASS** - A form of grading whereby a student receives a grade of P or NP instead of an A, B, C, D, or F. A P for class work is equivalent to a grade of C or above.

**PERMIT TO REGISTER** - A form listing an

appointment day and time at which the student may register. The permit is issued to all new students upon acceptance to the College and to all continuing students.

**PLACEMENT TEST** - Tests given prior to admission which are used to determine the student's appropriate class level in Math and English.

**PREREQUISITE** - A requirement that must be satisfied before enrolling in a particular course - usually a previous course or a test score.

**PREREQUISITE - CHALLENGE** - A process by which a student may be excused from taking a prerequisite course based on previous knowledge or education.

**PROGRAM** - In Title 5, a "Program" is defined as a cohesive set of courses that result in a certificate or degree. However, in Program Review, colleges often define programs to include specific disciplines. A program may refer to student service programs and administrative units, as well.

**PROGRESS PROBATION** - After enrolling in 12 units a student whose total units for which a W, NCR, or I has been assigned equals 50 percent or more of the units enrolled is placed on progress probation. A student whose cumulative number of units (beginning Fall 1981) for which a W, NCR, or I has been assigned equals 50 percent or more for two consecutive semesters is subject to dismissal from the College.

**QUALITATIVE DATA** - Qualitative data are descriptive information, such as narratives or portfolios. These data are often collected using open-ended questions, feedback surveys, or summary reports, and may be difficult to compare, reproduce, and generalize.

**QUANTITATIVE DATA** - Quantitative data are numerical or statistical values. These data use actual numbers (scores, rates, etc.) to express quantities of a variable.

**RECOMMENDED** - A condition of enrollment that a student is advised, but not required to meet, before enrollment in a course or program.

**RD** - Report Delayed. This temporary administrative symbol is recorded on the student's permanent record when a course grade has not been received from the instructor. It is changed to a letter grade when the grade report is received.

**RPT** - Course can be repeated for credit.

**REGISTRATION** - The process whereby a continuing student or a new or reentering student whose application has been accepted formally enters the College for a specific semester, enrolls in classes, and receives an ID Card.



**RETURNING STUDENT** - A student registering for classes who attended any of the Los Angeles Community Colleges in a prior semester but is not currently attending or eligible to be considered a continuing student.

**RUBRIC** - A rubric is a set of criteria used to determine scoring for an assignment, performance, or product. Rubrics may be holistic, not based upon strict numerical values which provide general guidance. Other rubrics are analytical, assigning specific scoring point values for each criterion often as a matrix of primary traits on one axis and rating scales of performance on the other axis. A rubric can improve the consistency and accuracy of assessments conducted across multiple settings.

**SATISFACTORY COMPLETION** - Completion of a course with a grade of "C" or better.

**SCHEDULE OF CLASSES** - An online or printed booklet used during registration giving the Subject Title, Course Number, Course Title, Units, Time, Instructor, and Location of all classes offered in a semester.

**SEMESTER** - One-half of the academic year, usually 15 weeks.

**STUDENT LEARNING OUTCOME (SLO)** - Student learning outcomes (SLOs) are specific observable or measurable results that are expected subsequent to a learning experience. These outcomes may involve knowledge (cognitive), skills (behavioral), or attitudes (affective) that provide evidence that learning has occurred as a result of a specified course, program activity, or process. An SLO refers to an overarching outcome for a course, program, degree or certificate, or student services area (such as the library).

**SUBJECT** - An academic discipline in which knowledge customarily is assembled for study, such as Art, Mathematics, or Biology.

**SUBJECT DEFICIENCY** - Lack of credit for a course or courses required for a particular objective, such as graduation or acceptance by another institution.

**SUBSTANDARD GRADE** - An earned grade of D or F.

**SECTION NUMBER** - A four-digit class identification number which appears in the first column in the class schedule before the time of day or evening the class meets.

**TRANSFER** - Changing from one collegiate institution to another after having met the requirements for admission to the second institution.

**TRANSFERABLE UNITS** - College units earned through satisfactory completion of courses which have been articulated with four-year institutions.

**TRANSCRIPT** - An official list of all courses taken at a college or university showing the final grade received for each course.

**TRANSFER COURSES** - Courses designed to match lower division courses of a four-year institution and for which credit may be transferred to that institution.

**UNITS** - The amount of college credit earned by satisfactory completion of a specific course taken for one semester. Each unit represents one hour per week of lecture or recitation, or a longer time in laboratory or other exercises not requiring outside preparation.

**UNITS ATTEMPTED** - Total number of units in which a student is enrolled beyond the fourth week of the semester.

**UNITS COMPLETED** - Total number of units in the courses for which a student received a grade A, B, C, D, F, or CR.

**UNITS ENROLLED** - Total number of units in which the student is enrolled at the end of the non-penalty drop period and the total number of units for all courses appearing on the student's transcript.

**W** - An administrative symbol assigned to a student's permanent record for all classes which a student has dropped or has been excluded from by the instructor after the end of the non-penalty drop date but before the last day to drop.

**WEB-ENHANCED COURSE** - A regular class that utilizes online content for course content and/or activities.

**WITHDRAWAL** - The action a student takes in dropping all classes during any one semester and discontinuing coursework at the College.

# INDEX

## A

Academic Freedom ..... 234  
 Academic Honors ..... 52  
 Academic Probation & Dismissal ..... 54  
 Academic Renewal ..... 51  
 Academic Standards and Credit Policies ..... 51  
 Academic Standards for Probation & Dismissal ..... 54  
 Accounting Courses ..... 185  
 Accuracy Statement ..... 5  
 Adding Classes ..... 30  
 Administration of Justice Courses ..... 185  
 Administration of Justice Program ..... 127  
 Admissions and Registration ..... 17  
 American Sign Language Courses ..... 187  
 Anatomy Courses ..... 187  
 Anthropology Courses ..... 187  
 Anthropology Program ..... 127  
 Art Courses ..... 188  
 Art Program ..... 122  
 Articulation Agreements ..... 113  
 Associate Degrees ..... 9  
 Associated Students Organization ..... 76  
 Athletics ..... 108  
 Attendance ..... 30  
 Auditing ..... 32

## B

Basic Skills ..... 98  
 Biology Courses ..... 190  
 Biology Program ..... 166  
 Board Rules ..... 235  
 Bookstore ..... 103  
 Bridges to Success ..... 98  
 Business Administration Programs ..... 137  
 Business Courses ..... 191

## C

CAFYES Program ..... 88  
 CalWORKs ..... 86  
 California Residency Requirements ..... 21  
 California State University ..... 116  
 Cancellation of Classes ..... 32  
 Career Center ..... 100  
 Change of Address ..... 22  
 Chemical Dependency Counselor Certificate ..... 126

Chemistry Courses ..... 191  
 Child Development Center ..... 147  
 Child Development Courses ..... 192  
 Child Development Program ..... 149  
 Citizenship Courses ..... 206  
 Clubs and Organizations ..... 78  
 College Administration ..... 5  
 College Advisory Committees ..... 99  
 College Goals and Objectives ..... 11  
 College History ..... 7  
 College Information ..... 10  
 Communication Studies Courses ..... 194  
 Communication Studies Program ..... 122  
 Community Services ..... 97  
 Complaint Procedures ..... 231  
 Compliance Officer ..... 240  
 Computer Applications and Office Technologies Courses ..... 195  
 Computer Applications and Office Technology Program ..... 137  
 Computer Science & Information Technology Courses ..... 197  
 Computer Science & Information Technology Program ..... 137  
 Concurrent Enrollment ..... 33  
 Consumer Information Requirements ..... 231  
 Counseling Services ..... 84  
 Course Descriptions ..... 184  
 Course Repetition and Activity Repetition ..... 33  
 Credit by Examination ..... 36  
 Credit for Courses from Non-Accredited Institutions ... 35  
 Credit for Prerequisites ..... 46

## D

Deputy Sheriffs Services ..... 94  
 Disability Services ..... 90  
 Dismissal ..... 54  
 Distance Learning ..... 107  
 District Policies ..... 231  
 Dropping Classes ..... 31  
 Drug-Free Campus ..... 233

## E

eLearning ..... 107  
 Economics Courses ..... 201  
 Education Certificate ..... 126  
 Education Courses ..... 201  
 Educational Philosophy ..... 10



Educational Talent Search (ETS) .....	81	Incomplete Work .....	47
Electronics Courses .....	202	In-Progress Work .....	47
Electronics Technology Program .....	137	Instructional Programs .....	118
English as A Second Language Program .....	154	Instructional Television (ITV) .....	107
English Courses .....	204	Interdisciplinary Studies Program .....	122
English Program .....	154	International Students Admission (F-1 Visa) .....	25
English Writing Center .....	92	International Student Services .....	81
Enrollment Fee .....	20	<b>J</b>	
Enrollment Fee Assistance .....	22	Journalism Courses .....	213
Enrollment Fee Refund Policy .....	26	Journalism Program .....	154
Enrollment, High School Students .....	21	K-12 Students Admission .....	21
Equal Opportunity Policy .....	109	Kinesiology Courses .....	213
ESL Courses (Credit) .....	207	<b>L</b>	
ESL Courses (NonCredit) .....	206	Law Courses .....	216
Extended Opportunity Programs & Services (EOPS) ...	87	Law/Paralegal Program .....	137
<b>F</b>		Learning Disabilities Assessment .....	90
Family & Consumer Study Courses .....	208	Liberal Arts Program .....	127
Fee Exemption (Special Part-Time Students) .....	21	Liberal Studies Program .....	127
Final Examinations .....	50	Library .....	91
Finance Courses .....	208	Library Science Courses .....	216
Financial Aid Programs .....	60	Loans (Financial Aid Programs) .....	64
French Courses .....	208	Lost and Found .....	95
Freshman Year Experience .....	88	<b>M</b>	
Functions of the Community College .....	10	Management Courses.....	216
<b>G</b>		Map .....	249
Geography Courses .....	209	Math Lab .....	162
Geography Program .....	166	Mathematics Courses .....	208
Geology Courses .....	209	Mathematics Program .....	162
Geology Program .....	166	Mathematics: Computer Science Program .....	162
Glossary of Terms .....	242	Student Success and Support Program (formerly Matriculation) .....	28
Grade Request Procedures .....	28	Microbiology Courses .....	218
Grades & Grade Changes .....	50	Music Courses .....	219
Grading Symbols & Definitions .....	46	Music Program .....	122
Graduation Requirements .....	111	<b>N</b>	
Greater Avenues for Independence (GAIN) .....	85	Net Price Calculator .....	61
<b>H</b>		No Smoking Policy .....	223
Health Courses .....	210	Non-Resident .....	22
Health Center .....	80	Non-Resident Tuition Fee .....	22
History Courses .....	210	Non-Resident Tuition Refund Criteria .....	26
History Program .....	127	Nursing Courses .....	221
Honors Program .....	53	Nursing Program .....	170
Humanities Courses .....	212	<b>O</b>	
<b>I</b>		Ombudsperson .....	240
IGETC Information .....	118	Online Courses and Programs .....	108



Other Instructional Programs .....	120	Student Grievance Procedures .....	239
Outreach & Recruitment .....	81	Student Identification .....	19
<b>P</b>		Student Learning Outcomes .....	12
Pan American Studies Program .....	127	Student Rights and Privacy Policy .....	232
Parking Fee .....	95	Student Services & Resources .....	59
Parking Regulations .....	95	Student Success Center .....	93
Pass/No Pass .....	48	Student Success and Support Program .....	27
Passage Program .....	89	Study Load Limitations .....	51
Personal Safety Tips .....	94	Supervision Courses .....	229
Philosophy Courses .....	223	<b>T</b>	
Physical Science Courses .....	223	Table of Contents .....	3
Physics Courses .....	223	Theater Courses .....	229
Physics Program .....	166	Theater Program .....	122
Physiology Courses .....	224	Transcripts .....	26
Political Science Courses .....	224	Transfer Center .....	100
Political Science Program .....	127	TRIO Scholars Program .....	81
Prerequisite Challenge.....	45	<b>U</b>	
President's Message.....	4	Upward Bound .....	82
Probation .....	54	University of California (UCLA) .....	118
Program Requirements .....	120	University Transfer Information .....	112
Psychology Courses .....	225	<b>V</b>	
Psychology Program .....	127	Valedictorian .....	53
Publications .....	155	Veterans Services .....	93
Puente Program .....	89	<b>W</b>	
<b>R</b>		Withdrawal .....	48
Real Estate Courses .....	227		
Real Estate Program .....	137		
Registration .....	17		
Removal from Probation .....	55		
Residence Appeal .....	22		
Residence Reclassification .....	22		
Residency .....	21		
<b>S</b>			
Salutatorian .....	53		
Schedule of Classes .....	19		
Sexual Harassment Policy .....	233		
Sociology Courses .....	227		
Sociology Program .....	127		
Spanish Courses .....	228		
Spanish Program .....	154		
Standard for Student Conduct .....	231		
STEM Scholars Program .....	83		
Student Discipline Procedures .....	239		



## CAMPUS MAP AND DIRECTIONS



Los Angeles Southwest College is located at 1600 West Imperial Highway at Denker Avenue in South Los Angeles

**From Hawthorne & South Bay:**

Take the San Diego (405) Freeway north; then, exit at Imperial Highway. Turn right onto Imperial Highway and proceed east about three miles. The campus is one block east of Western Avenue.

**From Downtown Los Angeles:**

Take the Harbor (110) Freeway south; then, exit at Imperial Highway. Proceed west for about two miles to 1600 West Imperial Highway.

**From Inglewood & Lennox:**

Take Prairie Avenue South to Imperial Highway. Make a left and proceed east to Imperial Highway for about two miles. The campus is one block east of Western Avenue and Imperial Highway at Denker Avenue.

**From Compton & Watts:**

Take the 105 Freeway west to Vermont Avenue. Turn right and proceed north on Vermont Avenue for about ¼ mile. Turn left at the intersection of Vermont Avenue and Imperial Highway, and proceed west on Imperial Highway for about one mile.